

## Some Signal Processing Aspects in Software Defined Radios

**A. Meister, T. Ruuben**

*Department of Radio and Communication Engineering, Tallinn University of Technology,  
 Ehitajate str. 5, 19086 Tallinn, Estonia, phone: +3726202350; e-mail: ameister@lr.ttu.ee, truuben@lr.ttu.ee*

### Introduction

The term Software Defined Radio (SDR) had its origins in military intelligence receivers of the late 1980s and the early 1990s. Since then, the concept has been widely implemented commercially, especially in cellular radio applications. As a main purpose, a software defined receiver uses an ADC to digitize the analog signal in the receiver as close to the antenna as practical, generally at an Intermediate Frequency (IF). Once digitized, the signals are filtered, demodulated, and separated into individual channels using specialized DSPs called receive signal processors. Software defined radio can also work as transmitter performs coding, modulation etc. in the digital domain. Ideally, the software radio eliminates quite a bit of expensive analog signal processing circuitry and performs these functions in low-cost Digital Signal Processors (DSP) [1].

In the case of its simplest application, SDR hardware can be ack as signal capturing device. It samples the input data at a fixed rate and sampled data can be sent directly to the PC via Universal Serial Bus (USB) interface or it can be converted to a complex baseband signal and downsampled to lower sample rates before sent to PC. So, it does not do any other signal processing except for the complex baseband conversion and downsampling. Any spectral analysis or demodulation must be done in software by the PC.

Let's compare analog and digital receivers block diagrams. The conventional analog heterodyne radio receiver is picked in Fig. 1.

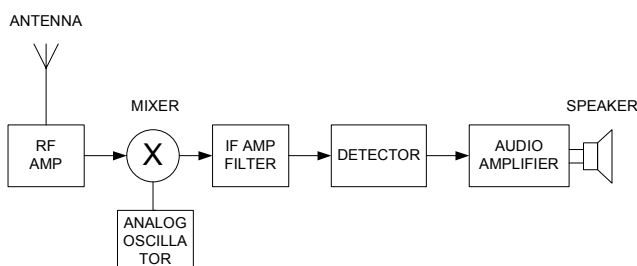

**Fig. 1.** Conventional heterodyne radio receiver

The mixer translates the desired input signal to the IF frequency as brought out in Fig. 2.

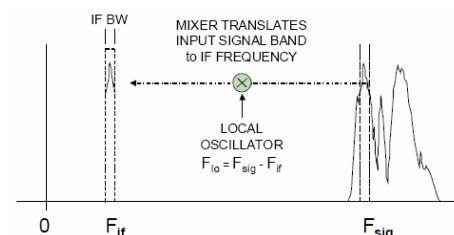

**Fig. 2.** Analog receiver mixing

This is called „downconversion“ because a signal at a high frequency is shifted down to a lower frequency by the mixer. At usual mixing of two signals both sidebands are always formed and therefore the bandwidth is doubled. To transmit information it is enough to use only one sideband. Below we will describe some methods how to reject unwanted sidebands.

The digital receiver block diagram is shown in Fig. 3.

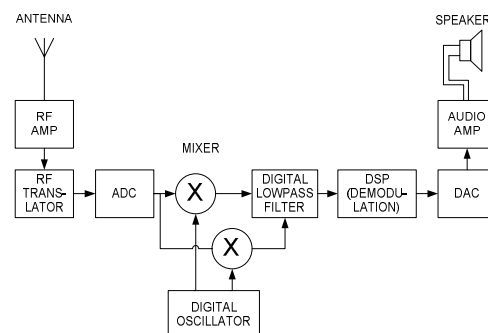

**Fig. 3.** Digital receiver block diagram

We can see that there is strong similarity to the analog receiver diagram. All of the basic principles of analog receivers still apply. However, the digital receiver chip or Digital DownConverter (DDC) is the heart of the digital receiver system and it consists three major sections: Local Oscillator, Mixer and Decimating Low Pass filter. The Mixer actually consists of two digital multipliers. Digital input samples from the Analog Digital Converter (ADC) are mathematically multiplied by the digital sine and cosine samples from the local oscillator and produce I and Q (in-phase and quadrature) outputs that are important for maintaining phase information contained in the input signal. At the output of the mixer, the high frequency wideband signals in the ADC input have been translated

down to DC with a shift or offset equal to the local oscillator frequency. Mixer product after the decimating filter in the frequency domain is shown in Fig. 4.

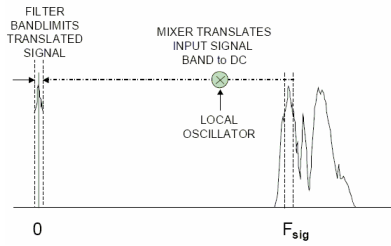

Fig. 4. Digital receiver mixer translation

The objective is to tune the local oscillator to center the signal of interest around 0 Hz so that the low pass filter can pass only the signal of interest. In practice it is essential to receive and process as high frequencies as possible. SDR can sample signals beyond its Nyquist sample rate using so called Undersampling Technique or Harmonic Sampling. There are physical limitations to the hardware that limit the practical highest frequency.

In this paper, we propose new low cost and compact searching receiver based on signal processing methods described here. Next we will describe these methods more precisely.

### Undersampling of passband signals

Undersampling of passband signals can be used to sample in ADC of SDR narrowband signals having bandwidth  $B \ll f_{max}$ , provided that the sampling frequency  $f_s$  is chosen depending on the signal bandwidth:  $f_s \geq 2B$ . The lowest acceptable sampling frequency must be  $f_{s|min} = 2f_2/k$ , where  $k$  is the integer number less or equal to  $f_2/B$ . Here  $f_2$  is the maximum signal frequency. For integer ratio  $f_2/B$ , the minimum sampling frequency is equal to  $2B$ . For example narrowband signal having center frequency  $f_1 = 69$  MHz and maximum frequency  $f_2 = 73$  MHz with bandwidth  $B = 4$  MHz, gives the ratio  $f_2/B = 18.25$ . Choosing  $k = 18$  (the nearest smaller integer) we get  $f_{s|min} = 2*73 \text{ MHz}/18 = 8.111$  MHz.

### Undersampling of narrowband HF signal

For narrowband HF signals undersampling is effectively used for transforming their frequency. This phenomenon allows significantly to enlarge the reception band of SDR. Possible frequency values of the signal to be transformed can be divided into Nyquist zones having the bandwidth  $\pm f_s/2$  around sampling frequency  $f_s$  and its multiples. The first Nyquist zone is up to  $f_s/2$  and signals inside this zone are normally digitized by ADC. Signals with frequency in higher zones undergo frequency transformation at sampling as shown on Fig.1. The resulting frequency after ADC is always in the zone I. To avoid possible interference from different zones, an adequate anti-aliasing analogue filter must be used before ADC. After ADC wanted and interfering signals add to each other and there is no way to improve the situation. Narrowband sampling must be complex-valued to preserve in-phase and quadrature components (complex envelope or I- and Q-channel signals).

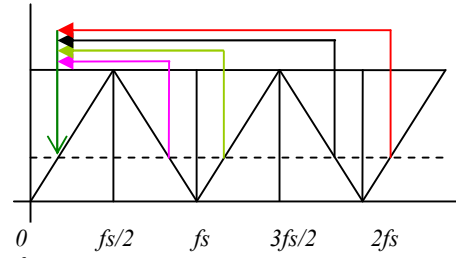

Fig. 5. Frequency translations at sampling in different Nyquist zones

### Single sideband techniques and image reject mixer

At arbitrary mixing of sine or cosine real-valued signals upper and lower sideband signals are produced as a result of multiplication procedure. To transmit information it is enough to use only one sideband as the well-known SSB technique does. At usual mixing of two signals both sidebands are always formed and therefore the bandwidth is doubled. In heterodyne receivers analogous transformations take place giving rise to so-called image frequency bands. These reception bands are mirrored relative to the local oscillator frequency and are located at  $f + f_{IF}$  or  $f - f_{IF}$  one of them being wanted band and another – unwanted image interference.

To suppress unwanted image band, many filtering methods have been used. In modern receivers special Image Rejection Mixers (IRM) can effectively replace the filtering, especially in inductance-free microelectronic equipment. Wideband and reprogrammable software defined radio SDR is one of these applications.

Two main versions of image rejection mixers are described in [2]. First of them, Hartley phasing method, is based on two-channel structure where sine and cosine channels are used. Input signal is given to sine channel and its Hilbert transform to cosine channel or vice versa. After multiplying with sine and cosine reference carrier wave the sum and difference signals are obtained, first of them corresponding to Upper Sideband (USB) and second to Lower Sideband (LSB). This well-known structure is used as an exact mathematical model for SSB modulators. Anyway, practical application of Hartley method is complicated mainly because of the need of wideband Hilbert transformer and critical balance of both channels.

Weaver method (Fig. 6.) avoids the need of Hilbert transformer replacing it with the second mixing with relatively low second local oscillator frequency  $f_2$ . Of course, double frequency transform gives rise to reversed output spectrum. Therefore in audio receiver where natural frequencies are of first importance, the first mixing frequency must be shifted by the value of  $f_2$ .

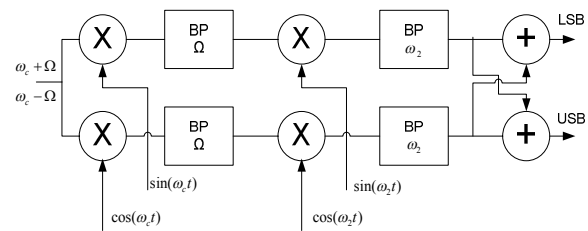

Fig. 6. Weaver method of image rejection

The dual-band image rejection mixer based on Gilbert cell has been described in [3, 4]. It is implemented into a Si chip using 0.25  $\mu\text{m}$  CMOS technology. Many manufactures are producing high frequency Gilbert cells (Harris HFA3101 and others).

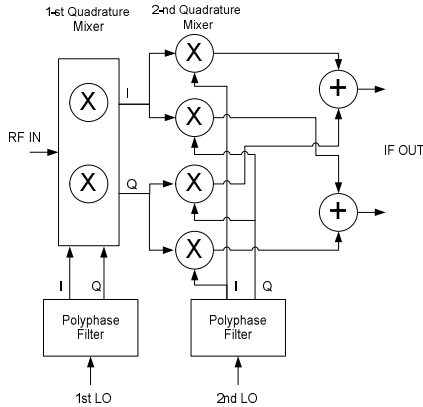

Fig. 7. Dual-band Gilbert cell

To compare two different frequencies, say  $f_1$  and  $f_c$ , Image Rejection Mixer (IRM) can be used as discriminator. If  $f_1 > f_c$ , one of its channels puts on upper output the signal having frequency  $f_1 - f_c + f_{c2}$ , otherwise another (lower) output gives a signal with frequency  $f_c - f_1 + f_{c2}$ . In both outputs the signals with frequencies higher than  $f_{c2}$  are suppressed by LP or BP filter.

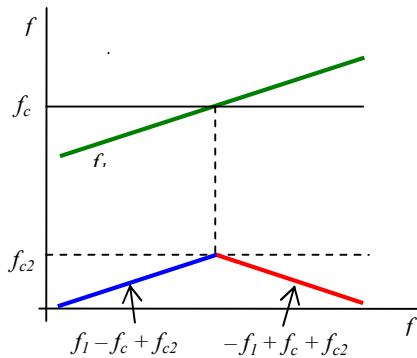

Fig. 8. Frequency comparison principle

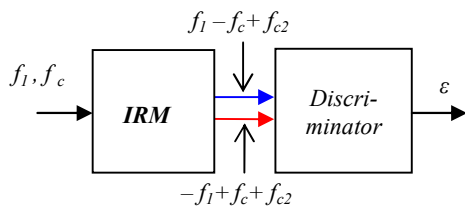

Fig. 9. Discriminator using IRM

The signal searching receiver using image rejection mixers is briefly described below [5]. The device is sweeping over the fixed band changing LO frequency. If the signal is detected at antenna output the system tries to fix whether the received signal has higher or lower frequency than LO. The error signal equal to the difference  $\epsilon$  of USB and LSB signal values is produced showing the direction of needed frequency adjustment.

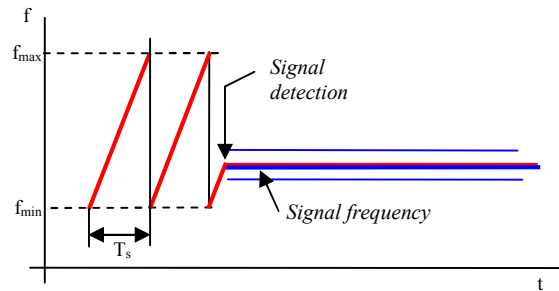

Fig. 10. Search receiver algorithm

Functioning of described Weaver structure image rejection mixer and its application in this search receiver was simulated using MATLAB Simulink model. The results obtained on low frequencies show that frequency locking zone is about 4 times the BPF (or LPF) bandwidth determining the system response. Main problems are the behavior in multiple-signal and noisy environment.

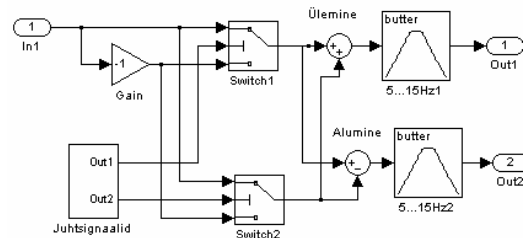

Fig. 11. Weaver IRM Simulink model

### Applications

In practice, we use software defined receiver SDR-14 for spectral analysis of signals. It is primarily a signal capturing device and samples input data at a fixed 66.67 MHz rate with 14 bit ADC converter and sends data to the PC via USB interface [6]. This device is unique because it can sample and buffer data at a high sample rates before sending it back to the PC. The digital down conversion provides a complex baseband signal that can be easily processed by the PC. The USB port allows demodulation or continuous processing of signals in up to about 150 kHz of bandwidth. Because the interface to the SDR-14 is open for the 3rd party developers, we can write our own custom application software. The structural scheme of the SDR-14 is depicted in Fig. 12.

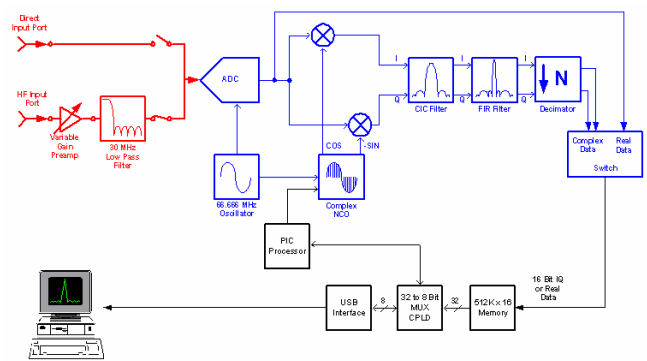

Fig. 12. SDR-14

Main applications can be:

1. Wide band weak signal measurement such as in radio astronomy

2. Antenna noise measurements.
3. General monitoring of signals in up to 30MHz wide bandwidths.
4. General receiver, DRM (Digital Radio Mondiale) applications.
5. Amateur radio monitoring. The wide band view of signals is ideal for being able to see what is going on during a contest or for just looking for activity.

However, our purpose is to monitor frequency bands up to GHz. So, we need to use some additional equipments and undersampling technology to do this. For control the additional equipments and the SDR-14 itself, we have our own software (written in C++) which GUI is depicted in Fig. 13.

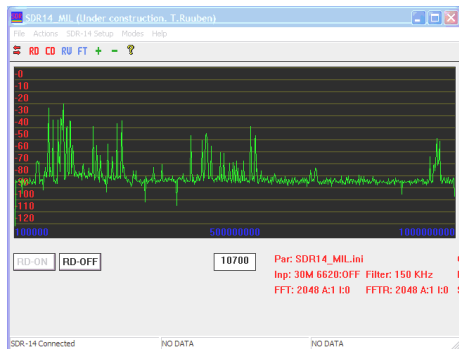

Fig. 13. GUI of the signal searching receiver

Because the off-the air electromagnetic environment is not under our control we need both high search speed and high resolution. We need high speed search because signals may be short duration and anywhere in GHz of spectrum and we need high resolution in order to resolve signals that are near to each other and to reduce the noise floor to reveal small signals. The SDR-14 receiver itself has only 30 MHz bandwidth. To use it in frequency bands up to GHz-s, we must divide the full band to so called sub-bands with maximum bandwidth 30 MHz. The question is, how fast and when we must switch the sub-bands (windows) from one to another and the same time how to control the additional equipments (downconverters) to get acceptable results. It is essential to synchronize downconverter control circuits with data blocks from SDR-14. The SDR-14 has different data transfer modes [7]. In the continuous data mode, the SDR sends an unsolicited Receiver State message back to the host after the specified

number of data blocks has been sent and this message can be used for synchronizing. Our experiments show, that it is possible to obtain search speed up to 1 GHz/s with the resolution at least 30 kHz and this all with relatively low cost and compact hardware.

## Conclusion

Software radios have significant utility for the military and cell phone services, both of which must serve a wide variety of changing radio protocols in real time. In the long term, software-defined radio is expected by its proponents to become the dominant technology in radio communications. We can say that it is the enabler of the cognitive radio. SDR can be built for very wide band if using different frequency translations at AD conversion. Single sideband technique and Weaver image rejection mixer allows to design search algorithms, possibly most useful in HF bands. Typical signal searching receivers cannot distinguish narrow signals while with the SDR-14 and a decent sized FFT, even 1 Hz resolution is possible. Of course, in the case of relatively wide bandwidth it is not so easy to do but we can realize our system by using different searching steps with different bandwidth.

## References

1. **Rodger H. Hosking**, Digital Receiver Handbook: Basics of software Radio. Sixth Edition. – Pentek, Inc. – USA. – 2006.
2. **Desjardins G. M.** Image-Rejection Mixers. – University of Toronto. – 2001.
3. **Harvey J., Harjani R.** An Integrated Quadrature Mixer with Improved Image Rejection at Low Voltage // 14th International Conference on VLSI Design. – January 2001.
4. **Haruoka M., et al.** A Dual-band Image-reject Mixer for GPS with 64dB Image Rejection. – Osaka University, Japan. – e-mail: haruoka@eie.eng.osaka-u.ac.jp.
5. **Luck A. J.** Radio Frequency Energy Jamming System / US Patent 5321405. – 1994.
6. **SDR-14 User's Guide** version 1.2. Software Define Receiver & Spectrum Analyzer. – RFSPACE. – 2005.
7. **SDR-14 Interface Specification**. Ver. 0.05. – MoeTronix. – 2005. Accessed at: www.moetronix.com.

Submitted for publication 2008 02 15

**A. Meister, T. Ruuben. Some Signal Processing Aspects in Software Defined Radios // Electronics and Electrical Engineering. – Kaunas: Technologija, 2008. – No. 4(84). – P. 97–100.**

There is presented how software defined receiver can replace conventional analog receiver. Undersampling, single sideband techniques and two main versions of image rejection mixers are described. Finally, one actual receiver system with main results will be described. Ill. 13, bibl. 7 (in English, summaries in English, Russian and Lithuanian).

**A. Meister, Ruuben. Spodosy obrabotki signalov programnuopravlyаемых радиоприемников // Электроника и электротехника. – Каунас: Технология, 2008. – № 4(84). – С. 97–100.**

Предложен способ замены аналогового приемника программноуправляемым. Описываются методы дискретизации сигналов в односторонней полосе частот. Дана реальное схемное решение приемника и результаты исследования. Ил. 13, библи. 7 (на английском языке; рефераты на английском, русском и литовском яз.).

**A. Meister, T. Ruuben. Kai kurie programiškai valdomų radijo imtuvų signalų apdorojimo aspektai // Elektronika ir elektrotechnika. – Kaunas: Technologija, 2008. – Nr. 4(84). – P. 97–100.**

Parodoma, kaip programiškai valdomas imtuvas gali pakeisti įprastinį analoginį imtuvą. Aprašomi signalų diskretizavimo, vienos spektro juostos metodai. Aprašomos dvi pagrindinės vaizdų atmetimo maišytuvų versijos. Aprašoma viena reali imtuvo sistema ir pateikiami esminiai tyrimo rezultatai. Il. 13, bibl. 7 (anglų kalba; santraukos anglų, rusų ir lietuvių k.).

DOI: 10.5755/j02.eie.11143