

Radiomeasuring Thermal Flowmeter of Gas on the Basis of Transistor Structure with Negative Resistance

V.S. Osadcuk, A.V. Osadchuk, Y.A. Yushchenko

Vinnitsa National Technical University,

Khmelnitskiy highway, 95, Vinnitsa - 21021, Ukraine, ph.: (043259-84-81; e-mail: osadchuk69@mail.ru

Introduction

Radiomeasuring flowmeters with a frequency output have a series of advantages before analogue, which consist in substantial increase of antijamming ability that allows increasing measurement accuracy and the potency of starting signals. It also allows refusing from the amplifying arrangements and analog-to-digital converters in after-treatment of signals that rises profitability of instrumentation [1]. An additional advantage of such arrangements is lack of an external source of preheating as temperature sensitive bipolar transistors that are heated up due to a natural power of consumption.

Now intensive investigations on study of performances of analogue flowmeters [2] though investigations of parameters of flowmeters with a frequency output on the basis of reactive properties of transistor structures with a negative resistor are on an incipient state are conducted. In this connection the given work is devoted to investigations of a leading parameters of flowmeters of gas on the basis of the above mentioned structures.

Theoretical and Experimental Research

The circuit of a radiomeasuring thermal flowmeter presented on fig. 1. It represents the hybrid integrated circuit consisting of two complementary bipolar transistors VT1 and VT2, resistances R1-R3, passive inductivity L1 and blocking capacitor C1. The power supply on a direct current is realized with constant-voltage sources V1 and V2.

Bipolar VT1 and VT2 transistors are located in a measuring tube, with diameter of nine millimeters and length of 20 centimeters from steel X118H01T through which transits gas which rate of flux is necessary for measuring.

Before to proceed to calculation of parameters of a flowmeter, we shall consider the change of temperature on a surface of the integrated circuit of the arrangement. The analysis of thermal state of the integrated circuit is a difficult problem which solution is possible for making on the basis of mathematical modeling in view of physical proc-

esses and structural features of the integrated circuit. On the basis of results of mathematical modeling it is possible to optimize parameters of the microelectronic transducers. It is necessary to note, that modeling of thermal processes in integrated tenzotransducers on the basis of strain gauges is made in works [3], and calculations of allocation of temperature in an integrated planar circuit is made in works [4]. In the given work as against the mentioned above investigations attempt of modeling a thermal regime for structures of the microelectronic radiomeasuring flowmeters is made.

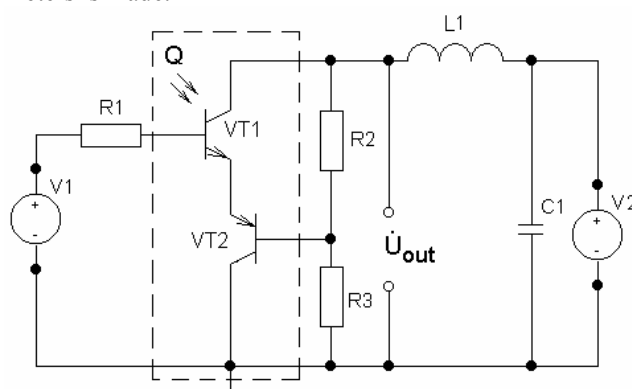

Fig. 1. A circuit of a radiomeasuring thermal flowmeter

Allocation of temperature in space and time in structure of a flowmeter is featured with the help of a heat conduction equation which looks like [5]:

$$c\rho \frac{\partial T}{\partial t} = F(x, y, z) + \lambda \left(\frac{\partial^2 T}{\partial x^2} + \frac{\partial^2 T}{\partial y^2} + \frac{\partial^2 T}{\partial z^2} \right), \quad (1)$$

where T - temperature, $F(x, y, z)$ - a power density of development of heat, c - specific heat of a substance, ρ - a denseness of a substance, λ - a heat conductivity of a substance, x, y, z - coordinates of transistors and resistances, t - time.

The stationary thermal field in volume and on a surface explored thermal models (fig. 2), proceed from expression (1), is featured by the equation

$$\frac{\partial^2 T(x, y, z)}{\partial x^2} + \frac{\partial^2 T(x, y, z)}{\partial y^2} + \frac{\partial^2 T(x, y, z)}{\partial z^2} = -\frac{1}{\lambda} F(x, y, z) \quad (2)$$

where $T(x, y, z)$ - a superheat temperature of a knot of a thermal model with coordinates x, y, z concerning temperature of a package of a temperature sensitive element.

Boundary conditions for a thermal model look like

$$\begin{cases} \left. \frac{\partial T(x, y, z)}{\partial x} \right|_{x=0, l_x} = \left. \frac{\partial T(x, y, z)}{\partial y} \right|_{y=0, l_y} = 0, \\ \left[\frac{\partial T(x, y, z)}{\partial z} - hT(x, y, z) \right]_{z=0} = 0, \\ \left[\frac{\partial T(x, y, z)}{\partial z} - hT(x, y, z) \right]_{z=l_z} = 0, \end{cases} \quad (3)$$

where $h = \alpha / \lambda$ - relative factor of heat exchange.

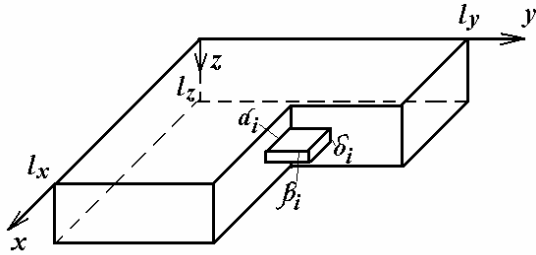

Fig. 2. A thermal model of the integrated structure flowmeter

Function $F(x, y, z)$ in the equation (2) defines a power density of development of heat that depends on geometrical sizes, dispositions and power of heat sources

$$F(x, y, z) = \sum_{i=1}^I \frac{f_i}{V_i} q_i(x) q_i(y) q_i(z), \quad (4)$$

where $V_i = \alpha_i \beta_i \delta_i$ - volume of a heat source with the number i , $q_i(x), q_i(y), q_i(z)$ - coordinate functions which adopt a value 1 in the field of an i - source and a value 0 outside of it.

The equations (2) - (3) are solved with the help of a method of integrated Fourier transforms [6] with terminating boundaries with application of the supposition of a superposition of temperature fields. Supposing, that

$$\begin{aligned} \tilde{T}(n, m, k) = \int_0^{l_x} \int_0^{l_y} \int_0^{l_z} T(x, y, z) \cos \frac{n\pi x}{l_x} \cos \frac{m\pi y}{l_y} \times \\ \times [\gamma_k l_z \cos \gamma_k z + h l_z \sin \gamma_k z] dx dy dz, \end{aligned} \quad (5)$$

where $\tilde{T}(n, m, k)$ - the plotting of temperature $T(x, y, z)$, γ_k - the positive solutions of an equation

$$\text{ctg} \gamma_k l_z = \frac{\gamma_k^2 - h^2}{2\gamma_k h} \quad (k = 0, 1, 2, \dots), \quad (6)$$

Then the equation (2) is transformed in space of plotting of the Fourier. For this purpose both parts of an equation (2) are multiplied on a nucleus of transformation (5) and integrated on x from 0 up to l_x , on y from 0 up to l_y , on z from 0 up to l_z .

Thus, in space of plotting of the Fourier the equation (2) will look like

$$\begin{aligned} \left[\left(\frac{n\pi}{l_x} \right)^2 + \left(\frac{m\pi}{l_y} \right)^2 + \gamma_k^2 \right] \tilde{T}(n, m, k) = \frac{1}{\pi \lambda^2} \sum_{i=1}^I \frac{8f_i}{nm\gamma_k} \times \\ \times \cos \frac{n\pi x_i}{l_x} \sin \frac{n\pi \alpha_i}{2l_x} \cos \frac{m\pi y_i}{l_y} \cos \frac{m\pi \beta_i}{2l_y} \times \\ \times (\gamma_k \cos \gamma_k z_i + h \sin \gamma_k z_i) \sin \gamma_k \frac{\delta_i}{2}, \quad (n \geq 1, m \geq 1). \end{aligned} \quad (7)$$

The formula of convolution for transformation (5) looks like

$$\begin{aligned} T(x, y, z) = \sum_{n=1}^{\infty} \sum_{m=1}^{\infty} \sum_{k=1}^{\infty} \left(8\tilde{T}(n, m, k) \cos \frac{n\pi x}{l_x} \cos \frac{m\pi y}{l_y} \times \right. \\ \left. \times (\gamma_k \cos \gamma_k z + h \sin \gamma_k z) \right) / \left((\delta_{n0} + 1)(\delta_{m0} + 1) l_x l_y l_z \times \right. \\ \left. \times [2hl_z + (h^2 + \gamma_k^2)l_z^2] \right); \end{aligned} \quad (8)$$

where δ_{n0}, δ_{m0} - a delta of function of Kronecker

$$\delta_{n0} = \begin{cases} 1 & n = 0 \\ 0 & n \neq 0 \end{cases}, \quad \delta_{m0} = \begin{cases} 1 & m = 0 \\ 0 & m \neq 0 \end{cases}$$

Taking into account, that

$$\tilde{T}(0, 0, 0) = \frac{1}{\lambda \gamma_0^2} \sum_{i=1}^I \frac{2f_i l_z}{\delta_i \gamma_0} (\gamma_0 \cos \gamma_0 z_i + h \sin \gamma_0 z_i) \sin \gamma_0 \frac{\delta_i}{2}, \quad (9)$$

$$\begin{aligned} \tilde{T}(n, 0, 0) = \frac{1}{\lambda \pi \left[\left(\frac{n\pi}{l_x} \right)^2 + \gamma_0^2 \right]} \sum_{i=1}^I \frac{4f_i l_x l_z}{n \alpha_i \delta_i \gamma_0} \cos \frac{n\pi x_i}{l_x} \times \\ \times \sin \frac{n\pi \alpha_i}{2l_x} (\gamma_0 \cos \gamma_0 z_i + h \sin \gamma_0 z_i) \sin \gamma_0 \frac{\delta_i}{2}, \end{aligned} \quad (10)$$

$$\begin{aligned} \tilde{T}(0, m, 0) = \frac{1}{\lambda \pi \left[\left(\frac{m\pi}{l_y} \right)^2 + \gamma_0^2 \right]} \sum_{i=1}^I \frac{4f_i l_y l_z}{n \beta_i \delta_i \gamma_0} \cos \frac{m\pi y_i}{l_y} \times \\ \times \sin \frac{m\pi \beta_i}{2l_y} (\gamma_0 \cos \gamma_0 z_i + h \sin \gamma_0 z_i) \sin \gamma_0 \frac{\delta_i}{2}, \end{aligned} \quad (11)$$

$$\tilde{T}(0, 0, k) = \frac{1}{\lambda \gamma_k^2} \sum_{i=1}^I \frac{2f_i l_z}{\delta_i \gamma_k} (\gamma_k \cos \gamma_k z_i + h \sin \gamma_k z_i) \sin \gamma_k \frac{\delta_i}{2}, \quad (12)$$

The formula of calculations of temperature in any point of volume of a flowmeter becomes

$$\begin{aligned} T(x, y, z) = T_c + \frac{2}{\lambda \gamma_0^3 l_x l_y v_0} \sum_{i=1}^I \frac{f_i}{\delta_i} (\gamma_0 \cos \gamma_0 z_i + h \sin \gamma_0 z_i) \times \\ \times \sin \gamma_0 \frac{\delta_i}{2} (\gamma_0 \cos \gamma_0 z_i + h \sin \gamma_0 z_i) + \frac{4}{\lambda \gamma_0 \pi l_x v_0} \times \\ \times \sum_{n=1}^{\infty} \frac{1}{n \left[\left(\frac{n\pi}{l_x} \right)^2 + \gamma_0^2 \right]} \sum_{i=1}^I \frac{f_i}{\alpha_i \delta_i} \cos \frac{n\pi x_i}{l_x} \sin \frac{n\pi \alpha_i}{2l_x} \times \\ \times (\gamma_0 \cos \gamma_0 z_i + h \sin \gamma_0 z_i) \sin \gamma_0 \frac{\delta_i}{2} \cos \frac{n\pi x}{l_x} (\gamma_0 \cos \gamma_0 z + \\ + h \sin \gamma_0 z) + \frac{4}{\lambda \gamma_0 \pi l_x v_0} \sum_{m=1}^{\infty} \frac{1}{m \left[\left(\frac{m\pi}{l_y} \right)^2 + \gamma_0^2 \right]} \times \end{aligned}$$

the gas consumption which is taking place through a measuring tube. For these purposes we shall take the advantage of the nonlinear equivalent circuit of the transducer. Proceeding from this circuit and the theory of durability of Lyapunov, we shall receive the function of transformation

$$F = \frac{1}{2\pi} \sqrt{\frac{A_1 + \sqrt{A_1^2 + L_1 C_{bx1} C_{ekv}^2(Q) R_g^2(Q)}}{2L_1 C_{bx1} C_{ekv}^2(Q) R_g^2(Q)}}, \quad (17)$$

where $A_1 = C_{ekv}^2(Q) R_g^2(Q) + R_g^2(Q) C_{ekv}(Q) C_{bx1} - L_1 C_{bx1}$, $C_{ekv}(Q)$ - equivalent capacity of impedance on electrodes a collector-collector of transistors VT1, VT2; $R_g(Q)$ - a negative resistor on electrodes a collector-collector of transistors VT1, VT2.

Graphical dependence of transformation function of a radiomeasuring flowmeter is presented on Fig. 4.

From the formula (17) the sensitivity function of a flowmeter is obtained

$$S_Q = -\frac{1}{8} \sqrt{2} \left(C_{ekv}(Q) R_g^3(Q) \left(\frac{\partial C_{ekv}(Q)}{\partial Q} \right) \sqrt{A_2 + C_{ekv}^2(Q) R_g^2(Q) C_{bx1}} \times \right. \\ \times \left(\frac{\partial C_{ekv}(Q)}{\partial Q} \right) + C_{ekv}^3(Q) R_g^3(Q) C_{bx1} \left(\frac{\partial C_{ekv}(Q)}{\partial Q} \right) - 2C_{ekv}^2(Q) R_g^2(Q) L_1 C_{bx1} \times \\ \times \left(\frac{\partial R_g(Q)}{\partial Q} \right) - 3C_{ekv}(Q) R_g(Q) L_1 C_{bx1} \left(\frac{\partial C_{ekv}(Q)}{\partial Q} \right) + 2C_{ekv}^3(Q) R_g^3(Q) L_1 \times \\ \times \left(\frac{\partial R_g(Q)}{\partial Q} \right) + C_{ekv}^2(Q) R_g^3(Q) L_1 \left(\frac{\partial C_{ekv}(Q)}{\partial Q} \right) - 2\sqrt{A_2} C_{ekv}(Q) L_1 \left(\frac{\partial R_g(Q)}{\partial Q} \right) - \\ \left. - 2\sqrt{A_1} R_g(Q) L_1 \left(\frac{\partial C_{ekv}(Q)}{\partial Q} \right) + 2C_{ekv}(Q) L_1^2 C_{bx1} \left(\frac{\partial R_g(Q)}{\partial Q} \right) + 2R_g(Q) L_1^2 C_{bx1} \times \right. \\ \left. \times \left(\frac{\partial C_{ekv}(Q)}{\partial Q} \right) \right) / \left(\sqrt{\frac{-R_g^2(Q) C_{ekv}(Q) C_{bx1} - R_g^2(Q) C_{ekv}^2(Q) - \sqrt{A_2 + L_1 C_{bx1}}}{L_1 C_{bx1} R_g^2(Q) C_{ekv}^2(Q)}} \right) \times \\ \times \pi \sqrt{A_2} L_1 R_g^3(Q) C_{ekv}^3(Q) \Bigg), \quad (18)$$

$$A_2 = R_g^4(Q) C_{ekv}^2(Q) C_{bx1}^2 + 2R_g^4(Q) C_{ekv}^3(Q) C_{bx1} -$$

where $-2L_1 C_{bx1}^2 R_g^2(Q) C_{ekv}(Q) + R_g^4(Q) C_{ekv}^4(Q) +$
 $+ 2L_1 C_{bx1} R_g^2(Q) C_{ekv}(Q) + L_1^2 C_{bx1}^2$.

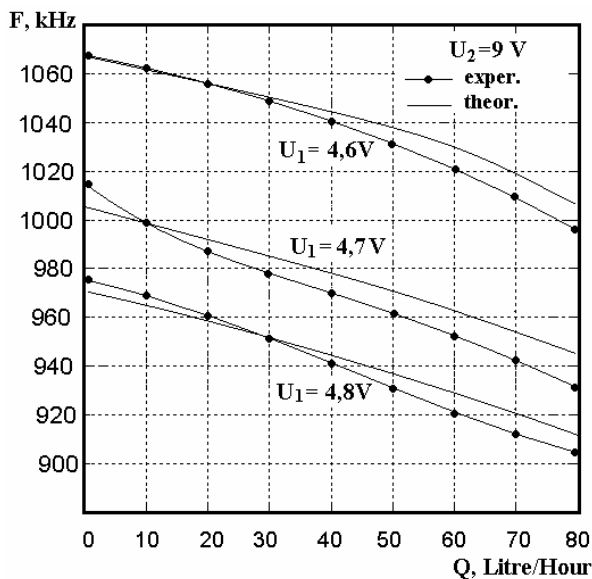

Fig. 4. Dependencies of transformation function of radiomeasuring flowmeter for the air

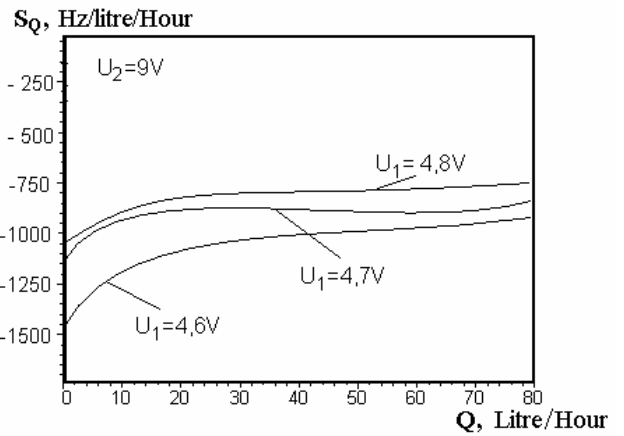

Fig. 5. Dependencies of sensitivity on air consumption

The graph of dependence of sensitivity from air consumption is presented on Fig. 5. One can see from the graph, sensitivity of the arrangement makes 760 - 1450 Hz /Litre/Hour.

Conclusions

The possibility of making of a radiomeasuring thermal gas flowmeter with a frequency output signal is shown on the basis of the autogenerating arrangement which will consist of two bipolar transistors used as temperature sensitive elements. The change of temperature of heat-sensitive bipolar transistors is proportionally to the gas consumption, passing through a measuring tube. Analytical dependencies of function of transformation and sensitivity are received. The thermal condition of the integrated circuit of the transducer is designed. Sensitivity of the arrangement makes 750 - 1450 Hz /Litre/Hour.

References

1. Новицкий П.В., Кноринг В.Г., Гутников В.С. Цифровые приборы с частотными датчиками. -Л.: Энергия, 1970. -424с.
2. Ураксеев М.А., Романченко А.Ф., Абдрашитова Д.Р., Шилов С.А. Перспективы термоанемометрических методов измерения расхода газа или жидкости. Электронный журнал «Исследовано в России» <http://zhurnal.ape.relarn.ru/articles/2001/051.pdf>.
3. Красильникова В.В. Моделирование тепловых режимов интегральных тензопреобразователей // Приборы и системы управления, 1991. №7. - С.16-17.
4. Осадчук В.С., Осадчук О.В., Яровенко А.Г. Дослідження теплових режимів мікроелектронного частотного перетворювача магнітного поля // Вимірювальна та обчислювальна техніка в технологічних процесах, 2000. №3. - С.47-51.
5. Лыков А.В. Теория теплопроводности. -М.: Высшая школа, 1967. - 596 с.
6. Смирнов М.М. Дифференциальные уравнения в частных производных второго порядка. -М.: Наука, 1964. -205 с.

Submitted for publication 2008 02 10

V.S. Osadcuk, A.V. Osadchuk, Y.A. Yushchenko. Radiomeasuring thermal flowmeter of gas on the basis of transistor structure with negative resistance // Electronics and Electrical Engineering. – Kaunas: Technologija, 2008. – No. 4(84). – P. 89–93.

In the given article the possibility of making of a radiomeasuring thermal gas flowmeter with a frequency output signal is shown on the basis of the autogenerating arrangement which will consist of two bipolar transistors used as temperature sensitive elements. The change of temperature of heat-sensitive bipolar transistors is proportionally to the gas consumption, passing through a measuring tube. Analytical dependencies of function of transformation and sensitivity are received. The thermal condition of the integrated circuit of the transducer is designed. Sensitivity of the arrangement makes 750-1450 Hz /Litre/Hour. Ill. 5, bibl. 6 (in English; summaries in English, Russian and Lithuanian).

В.С. Осадчук, А.В. Осадчук, Ю.А. Ющенко. Радиоизмерительный тепловой расходомер газа на основе транзисторной структуры с отрицательным сопротивлением // Электроника и электротехника. – Каунас: Технология, 2008. – № 4(84). – С. 89–93.

Показана возможность создания радиоизмерительного теплового расходомера газа с частотным выходным сигналом на основе автогенераторного устройства, которое состоит из двух биполярных транзисторов, выступающих в качестве термочувствительных элементов. Изменение температуры термочувствительных биполярных транзисторов пропорционально расходу газа, проходящего через измерительную трубку. Получены аналитические зависимости функции преобразования и чувствительности. Рассчитан тепловой режим интегральной схемы преобразователя. Чувствительность устройства составляет 750 – 1450 Гц/л/час. Ил. 5, библи. 6 (на английском языке; рефераты на английском, русском и литовском яз.).

V.S. Osadcuk, A.V. Osadchuk, Y.A. Yushchenko. Radijo matavimai naudojantis šiluminio srauto matuokliu dujų pagrindu pagamintu tranzistoriaus struktūros pagrindu // Elektronika ir elektrotechnika. – Kaunas: Technologija, 2008. – Nr. 4(84). – P. 89–93.

Darbe parodyta galimybė atlikti radijo matavimus su šiluminio srauto matuokliu dujų pagrindu. Temperatūriškai jautrūs elementai yra parodyti. Temperatūros pakeitimas temperatūriškai jautrių bipoliarių tranzistorių į proporcingą dujų kaitinimą, kurios praeina per esantį vamzdį. Analitinės transformacijos ir jautrumo funkcijos priklausomybės yra gautos. Šiluminio integruoto keitiklio režimai yra apskaičiuoti. Prietaiso jautrumas 750 - 1450 Hz/l/h. Il. 5, bibl. 6 (anglų k.; santraukos anglų, rusų ir lietuvių k.).

DOI: 10.5755/j02.eie.11141