

Comparison of Passive Chromatic Dispersion Compensation Techniques for Long Reach Dense WDM-PON System

S. Spolitis, V. Bobrovs, P. Gavars, G. Ivanovs

Department of Telecommunications, Riga Technical University

Azenes st. 12, LV-1010 Riga, Latvia, phone: +371 26151611, e-mail: sandis.spolitis@rtu.lv

crossref <http://dx.doi.org/10.5755/j01.eee.122.6.1112>

Introduction

Wavelength Division Multiplexed Passive Optical Network (WDM-PON) is an attractive solution to satisfy the worldwide growing demand for transmission capacity in the future next generation fiber optical access networks. The maximum reach of the Dense WDM-PON (DWDM-PON) transmission system can be severely limited by chromatic dispersion (CD) [1, 2].

A cost effective solution for an optical access network is the completely passive long-reach optical access network. The strength of this optical technology is its ability to displace electronics and optical elements in one central office (CO) and simplify the DWDM-PON network architecture [3]. In such a way the access and metro networks can be combined into one network through the use of an extended backhaul fiber, possibly to provide data transmission in length up to 100 km. In traditional Time-Division Multiplexed Passive Optical Network (TDM-PON), the number of ONUs is limited by optical splitter attenuation on single wavelength, but using WDM-PON technology we can provide 16, 32, 64 or even more wavelengths in optical access network [2, 4].

In the DWDM-PON network many separate wavelengths deliver downstream traffic to end users which are separated using wavelength splitter with low insertion loss (up to 3 dB) opposite TDM-PON where power splitter with high insertion loss (up to 14 dB for optical 16 channel system) is used [3, 5].

Therefore WDM-PON is assumed as an effective way to solve the bottleneck problem if we have large numbers of end users, because in this case each user receives its own wavelength. The amount of transmitted data for each client is growing up continuously, and currently WDM-PON is the most promising technology which can satisfy the growing demand for higher data transmission speeds in immediate future. To improve the performance of high-speed WDM passive optical network CD compensation is needed because it has an important role on a quality of

transmitted optical signal, amount of provided users and passive optical network reach [1-3].

Chromatic dispersion can be divided into two components - material and waveguide dispersion. The waveguide dispersion is caused by physical structure of the optical fiber's core and cladding. As a result different wavelengths propagate at different velocities in the core and cladding of optical fiber [6, 7]. Material dispersion is dominant part of CD, and it is caused by change of optical fiber's refractive index n with wavelength λ .

Dispersion causes optical signal pulses to broaden and lose their shape as they travel along the optical fiber. When pulses become wider, they tend to interfere with adjacent pulses and this leads to intersymbol interference (ISI). This interference limits the maximum achievable data transmission rate and distance of DWDM-PON network [7-9].

Due to the influence of ISI problems to restore transmitted information occurred there. In this case it is difficult to separate transmitted bit sequence at receiver side and it is resulting bit errors (high BER) or even failure of fiber optical transmission system. In order to operate a DWDM-PON system with a sufficiently low BER and minimize the performance degradation caused by optical pulse distortion and broadening, dispersion compensation is needed [6, 9].

Numerical Analysis and Measurement technique

Our accepted research method is a mathematical simulation using the OptSim 5.2 simulation software where using Split-Step algorithm the complex differential equation systems are solved. Optical fiber is affected by linear and nonlinear effects and the change of electromagnetic field is characterized by Maxwell's equations. In order to study the nonlinear effects in optical fiber the nonlinear Schrödinger equation (NLS) is used [9]. Except certain cases this equation cannot be solved analytically. Therefore, OptSim simulation software is

used for simulation of fiber optical transmission systems where it solves complex differential equations using Time Domain Split-Step (TDSS) method. This Split-Step method is being used in most commercial optical system simulation tools [9]. The principle of the method can be explained by the fiber propagation equation, which can be written in following way

$$\frac{\partial A(t,z)}{\partial z} = \{L+N\}A(t,z), \quad (1)$$

where $A(t,z)$ – optical field; L – linear operator responsible for dispersion and other linear effects; N – non-linear operator responsible for the nonlinear effects. It is assumed that linear L and nonlinear N effects affect the optical signal independently using the Split-Step method, if the span (step) of simulated optical fiber Δz is enough small.

Each step Δz consists of two half steps. In the first half step only linear effects (linear part) are taken into account, but in the second half step only nonlinear effects (nonlinear part) are taken into account.

All optical fiber length z is divided into steps Δz , and alternately linear and nonlinear effects are considered. For the most accurate results, it is necessary to carefully choose a step Δz . If this step Δz is chosen too small, it will increase the time necessary to perform calculations, but if the step is chosen too large it will decrease accuracy of the calculations. In our case the simulation of more than 1024 bits is made to achieve result's estimation accuracy not less than 95% [9].

Chromatic dispersion compensation methods

Dispersion compensation modules (DCM) (also called dispersion compensation units - DCU) can be used for chromatic dispersion compensation and system performance improvement in fiber optical transmission systems. These modules can provide a fixed or tunable amount of compensating CD value [7, 9].

Dispersion compensating fiber (DCF) and fiber Bragg grating (FBG) can be used for chromatic dispersion compensation modules in our investigated DWDM-PON system. Typically DCM is specified by what length, in km, of standard single mode fiber (SMF) will be compensated or by the total compensation value of CD over a specific wavelength range, specified in ps/nm .

DCM can be placed before or after standard SMF span. In our research pre-compensation and post-compensation schemes (configurations) for effective chromatic dispersion compensation are employed, and according to this position the compensation type is pre-compensation or post-compensation. [1].

The dispersion compensation module containing DCF typically has a high fiber attenuation and accordingly insertion loss resulting from the insertion of a device in fiber optical transmission line will be high. These DCM optical losses can be compensated by optical amplification. The effective core area A_{eff} of a DCF is much smaller than standard ITU-T G.652 single mode fiber thereby dispersion compensating fiber experience much higher optical signal distortions caused by nonlinear optical effects (NOE). Impact of nonlinear optical effects can be reduced by lowering optical power [10].

It must be considered that DCF adds polarization mode dispersion (PMD) to the fiber optical transmission link, which value typically is 0.1 ps/ \sqrt{km} . The reason of PMD is different frequency components of pulse which are travelling with different velocities and has different polarization states, resulting in pulse broadening. Polarization mode dispersion becomes a limiting factor for high speed optical communication systems with data rate over 10 GBit/s [7].

It is also available dispersion compensation modules with chirped fiber Bragg grating (FBG) for chromatic dispersion compensation. Chirped fiber Bragg grating is very suitable for WDM systems because it has good optical characteristics and as the DCF it is a completely passive unit. FBG has grating period which is not constant but changes linearly over the length of the grating with the shorter grating period located at the beginning of the grating. Grating period is distance between two adjacent maximum values of the refractive index [7].

The fiber grating reflects a narrow spectrum of wavelengths that are centered at λ_B and passes all the other wavelengths. Reflected wavelength λ_B can be obtained by following equation

$$\lambda_B = 2\Lambda n_g, \quad (2)$$

where λ_B - reflected wavelength, nm; Λ - grating period, nm; n_g - fiber's effective group refractive index. When the dispersion affected input pulse with width τ passes through the Chirped fiber Bragg grating, pulse width is decreased by $\Delta\tau$ and its shape is restored on the output.

Chirped fiber Bragg grating has shorter grating periods at beginning but over the length of the grating these periods linearly increase. Therefore shorter signal wavelengths are reflected sooner and have less propagation delay through the FBG but longer signal wavelengths travel further into the fiber grating before they are reflected back and accordingly have more propagation delay through the FBG. Chirped fiber Bragg grating impact is exactly opposite to chromatic dispersion of optical fiber where longer signal wavelengths are affected most of all. Typically the length of the fiber grating is from 10 to 100 cm [9]. A significant advantage of using a fiber Bragg grating dispersion compensation modules over DCF fiber is its relatively small insertion loss resulting from the insertion of a device in fiber optical transmission system. For comparison, commercial DCF specified to compensate accumulated chromatic dispersion of 100 to 120 km standard single mode fiber span have about 10 dB of insertion loss, whereas a FBG based dispersion compensation module, capable to compensate the same fiber span length, insertion loss is only up to 4 dB. In contrast to DCF DCM, FBG based dispersion compensation module can be used at higher optical powers without inducing nonlinear optical effects [1].

Simulation model

For investigation of chromatic dispersion pre-compensation and post-compensation methods for reach improvement of high speed 16 channel DWDM-PON

system we realized a simulation scheme in OptSim 5.2 software, see Fig. 1.

The performance of simulated scheme was evaluated by the obtained Bit Error Ratio (BER) value of each WDM channel in the end of the fiber optical link. It should be noticed that ITU recommended BER value for fiber optical transmission systems with data rate 10 Gbit/s per channel is less than 10^{-9} [7].

As one can see in Fig. 1, DWDM-PON simulation scheme consists of 16 channels. The frequency grid is anchored to 193.1 THz and channel spacing is chosen equal to 100 GHz frequency interval. Such an interval and frequency grid is defined in ITU-T recommendation G.694.1. Optical Line Terminals (OLT) are located at central office (CO). Each OLT consists of data source, NRZ driver, continuous wavelength (CW) laser and external Mach-Zehnder modulator (MZM). Each data source generates optical data stream with mean launched power +2dBm (this power level correspond with ITU-T 987.2 recommendation as N1 class) and data rate is equal to 10 Gbit/s.

This data stream represents the information needed to transmit in fiber optical transmission system. Information from OLT is transmitted to an optical network terminal (ONT) or user over the fiber optical transmission link called optical distribution network (ODN). ODN includes the physical fiber and optical devices that distribute optical signals from CO to users in a passive optical network. Conventional intensity modulation direct-detection (IM-DD) is chosen as modulation format. As coding scheme NRZ coding is chosen, because it is one of the most easily implemented and historically dominated coding schemes in optical data transmission networks. Using intensity modulation the intensity of the carrier optical wave is varied from high optical power to minimum optical power in this manner representing 1 or 0 pulses [8, 9].

Generated bit sequence from data source is sent to NRZ driver where NRZ pulses are formed. Afterwards formed electrical NRZ pulses are sent to Mach-Zehnder modulator. Finally the CW laser light beam is modulated

via the Mach-Zehnder modulator and optical pulses are formed. These formed optical pulses are coupled by optical coupler (arrayed waveguide grating (AWG) multiplexer) from all WDM channels and sent into standard ITU-T G.652 single mode fiber (SSMF).

In our simulation scheme ODN consists of AWG multiplexer, two optical attenuators (simulates AWG multiplexer and demultiplexer insertion loss for 16 channel DWDM-PON system), optical erbium doped fiber amplifier (EDFA) with fixed output power +12 dBm (equal to 15.85 mW), above mentioned standard single mode fiber (SMF) with variable length and AWG demultiplexer.

For CD pre-compensation there is used PRE-DCM block, but for CD post-compensation there is used POST-DCM block in OptSim simulation model. Symmetrical CD compensation when pre- and post- compensation is used simultaneously isn't investigated in our research.

Simulated high-performance DWDM AWG multiplexers and demultiplexers are absolutely passive optical components (no need for thermal regulation and monitoring electronics) with insertion loss up to 3dB and channel spacing 100 GHz each. Originally the standard optical single mode fiber in length of 20 km was used in our research. Such a fiber span length is defined in ITU-T recommendation G.984.2 as a maximum fiber distance between optical line terminal (OLT) and optical network terminal (ONT) in Gigabit Passive Optical Network (GPON). At the end of optical distribution network there is a 1x16 AWG demultiplexer where optical signal is split into 16 optical streams (wavelengths) and sent to receiver section. In the end of fiber optical network each channel is analyzed separately after the optical filtering.

Receiver section includes ONTs. Each ONT consists of sensitivity receiver with optical filtering and PIN photodiode, Bessel electrical filter (5 poles, -3dB Bandwidth $Bw_E = 7.5$ GHz), optical power meter and electrical probe to evaluate the quality of received optical data signal. For separation of each WDM channel from a common optical stream there are necessary optical filters.

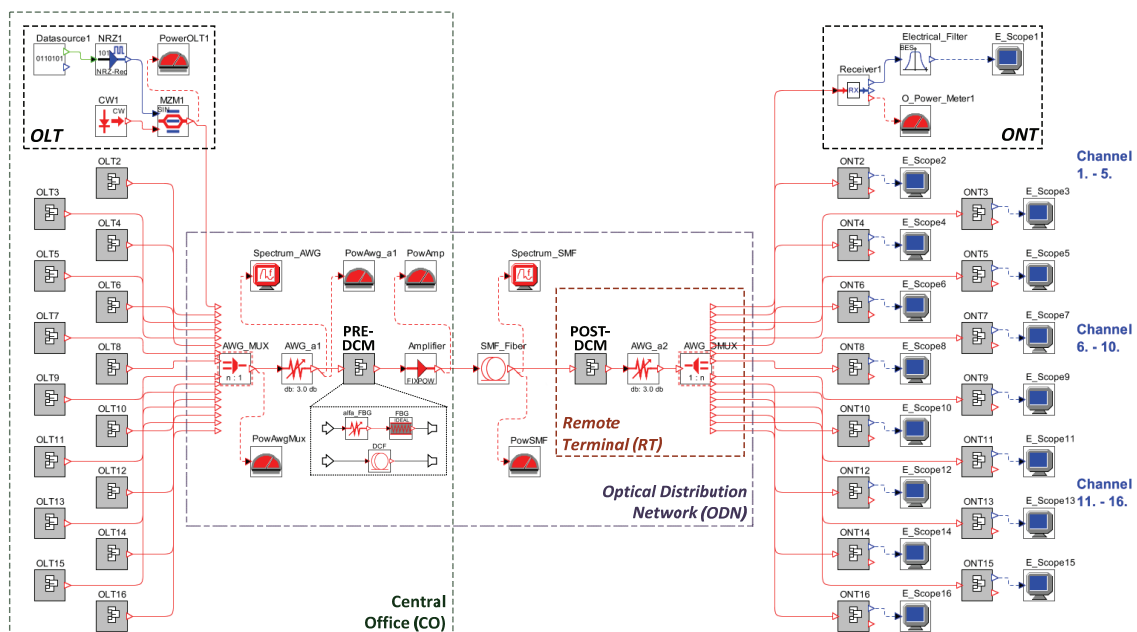

Fig. 1. Simulation model of 16-channel DWDM-PON system with dispersion pre- and post-compensation modules (PRE-DCM and POST-DCM)

After optical filtering each channel is converted to electrical signal using PIN photodiode and filtered by Bessel electrical filter to reduce the noise of electrical signal [1, 7].

Results and discussion

There are two different chromatic dispersion (CD) compensation methods for reach improvement of DWDM-PON system described in this work. These CD compensation methods that can be implemented in DCM module are FBG and DCF. We have investigated dispersion pre- and post-compensation schemes as well as compared these above mentioned CD compensation methods.

The aim of this chapter is to numerically evaluate the performance of these methods and find the best suitable method which allows at most increasing the length of our investigated DWDM-PON simulation scheme.

As one can see in Fig. 2, without CD compensation (without any DCM) and using optical EDFA amplifier (with fixed output power +12 dBm) over the SMF fiber of 20 km in length we obtained that BER value of received optical signal from the worst channel was very low ($BER=1.40 \cdot 10^{-17}$) and it means that our investigated DWDM-PON system's performance is high. Lower BER level leads to higher quality of overall system. For our evaluated system the maximum allowed $BER < 10^{-9}$.

We have obtained that the highest BER value (lowest performance) was produced by 8th channel of our investigated DWDM-PON system's model and basis on this observation we show in this paper simulation results only for this - worst channel.

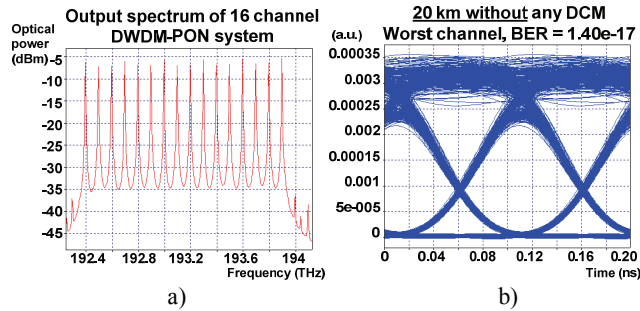

Fig. 2. Output spectrum, eye diagram and BER value of the 8th channel of DWDM-PON system without dispersion compensation module (DCM)

As the BER for worst channel was very low at 20 km, it means that in our case we have enough performance's (optical power and chromatic dispersion budget) reserve or margin to increase DWDM-PON system link length until the minimum allowed level of BER value.

Therefore, by increasing the transmission distance it was found that the maximum achievable data transmission distance between OLT and ONT is about 57 km with optical amplification and without usage of any CD compensation. It means that without CD compensation the optical signal transmission in our DWDM-PON system over 57 km of SSMF span with $BER < 10^{-9}$ is impossible. As one can see, results and eye diagram of the worst

channel of our simulated DWDM-PON system are shown in Fig 3.

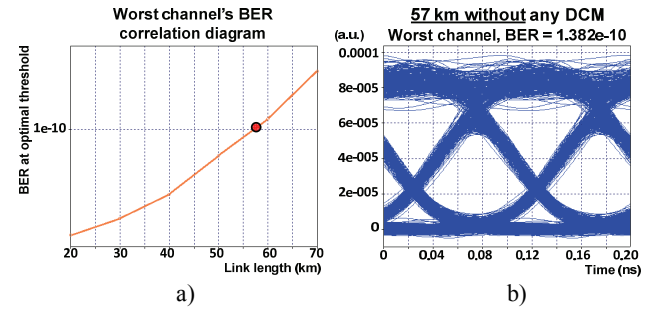

Fig. 3. DWDM-PON system's worst channel BER correlation diagram, output eye diagram of detected signal and BER value at maximum achievable link length without CD compensation module

the implementation of DCM with dispersion compensating fiber (DCF) in central office (CO) or in remote terminal (RT). In CO there is used PRE-DCM module for pre-compensation, but in case of post-compensation there is used POST-DCM module in RT. Employed DCF has a small effective core area $A_{eff} = 20 \mu m^2$, large attenuation $\alpha = 0.55 \text{ dB/km}$ and large negative dispersion $D = -80 \text{ ps/(nm} \cdot \text{km)}$ at the reference wavelength $\lambda = 1550 \text{ nm}$.

By investigating the usage of DCF for CD pre-compensation (PRE-DCM) we found that the optimal required DCF fiber length to reach optimal DWDM-PON system performance is 7 km, see Fig. 4. Using DCF fiber of 7 km in length we can achieve the maximum DWDM-PON system's link length of 68 km. It means that usage of DCF fiber gives us the opportunity to increase the length of our long-reach PON for an additional 11 km or extra 19.3%.

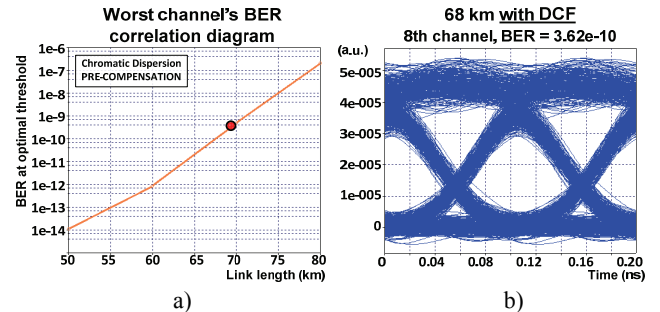

Fig. 4. DWDM-PON system's worst channel BER correlation diagram, output eye diagram of detected signal and BER value at maximum achievable link length with CD pre-compensation module employing DCF fiber

It was found that in case of 16 channel DWDM-PON system, the full accumulated chromatic dispersion is not necessary. The total accumulated CD amount of 68 km long SMF fiber span is about 1100 ps/nm, but using DCF fiber of 7 km in length we can compensate CD amount of 560 ps/nm. Here it is found that for optimal 16 channels DWDM-PON system performance it is sufficient to compensate a half (50%) of the total accumulated CD amount instead of full CD compensation.

In case when DCF fiber is used for CD post-compensation in remote terminal (POST-DCM) we found that the optimal required DCF fiber length to reach optimal DWDM-PON system performance is 2 km, see Fig. 5.

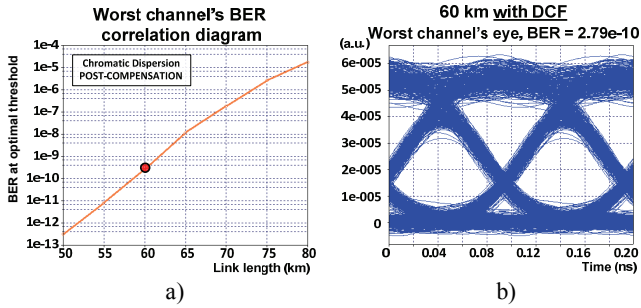

Fig. 5. DWDM-PON system's worst channel BER correlation diagram, output eye diagram of detected signal and BER value at maximum achievable link length with CD post-compensation module employing DCF fiber

Using DCF fiber of 2 km in length we increased the length of our long-reach passive optical network for an additional 3 km (extra 5.3 %) and achieved that the maximum DWDM-PON system's link length is 60 km.

The second realized CD compensation method for DWDM-PON system includes the implementation of Fiber Bragg Grating (FBG) in central office (CO) and in remote terminal (RT). In CO there is used PRE-DCM module for pre-compensation, but in case of post-compensation there is used POST-DCM module in RT.

By realizing simulation model with FBG dispersion compensating scheme in CD pre-compensation configuration (PRE-DCM), we have found that BER value decreased and system performance improved. This improvement was greater than if we use DCF fiber for CD compensation, no matter in configuration of pre- or post-compensation, see Fig. 6. It was found that optimal CD compensation amount that must be compensated by FBG in pre-compensation configuration is 1100 ps/nm.

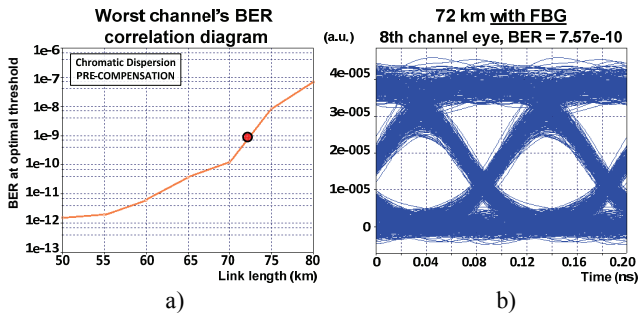

Fig. 6. DWDM-PON system's worst channel BER correlation diagram, output eye diagram of detected signal and BER value at maximum achievable link length with CD pre-compensation module employing FBG

This amount is equivalent to the full CD compensation. Using FBG for CD pre-compensation the total reach of DWDM-PON system was extended by 15 km - from 57 km initially to 72 km now. The line length increase of 26.3% was obtained, see Fig.6.

This result can be explained by the fact that FBG has relatively small insertion loss (< 4 dB) and instead of DCF fiber it can be used at higher optical powers without inducing nonlinear optical effects, which can reduce the system's performance.

By investigating the usage of FBG for CD post-compensation in remote terminal (POST-DCM) we found

that optimal CD compensation amount that must be compensated by FBG in this configuration is -700 ps. In this configuration it was necessary to increase the output power of EDFA (from 12 to 15 dBm) to cover FBG module insertion loss (3dB), because it was concluded that with the existing power budget significant reach improvement can't be achieved and system's performance is below required threshold.

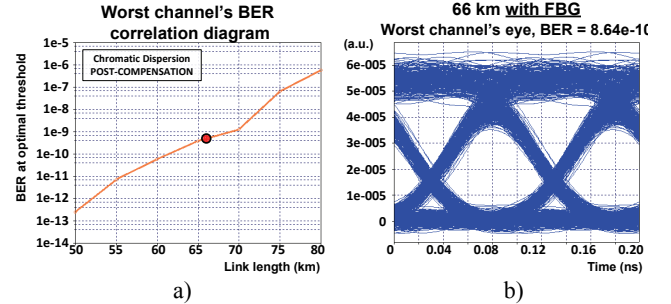

Fig. 7. DWDM-PON system's worst channel BER correlation diagram, output eye diagram of detected signal and BER value at maximum achievable link length with CD post-compensation module employing FBG

Using FBG for CD post-compensation the total reach of DWDM-PON system was extended by 9 km - from 57 km initially to 66 km now, and the line length increase of 15.8 % was obtained.

All results that were obtained using DCF and FBG in pre- and post-compensation configuration are summarized below in Table 1.

Table 1. Comparison of different chromatic dispersion pre- and post-compensation schemes for Dense WDM-PON system

Compensation Type	Compensation technique used in DCM	Extra gained length, +%	Extra gained length, km	Maximal link length, km
Without CD compensation	-	-	-	57 \pm 2.9
Pre-compensation (DCM placed before 57 km SMF span)	DCF	19.3 \pm 1.0	11 \pm 0.6	68 \pm 3.4
	FBG	26.3 \pm 1.3	15 \pm 0.8	72 \pm 3.6
Post-compensation (DCM placed after 57 km SMF span)	DCF	5.3 \pm 0.3	3 \pm 0.2	60 \pm 3.0
	FBG	15.8 \pm 0.8	9 \pm 0.5	66 \pm 3.3

Conclusions

In this work using OptSim simulation software we have realized an experimental high-speed DWDM-PON system model where DCF fiber and FBG are used for accumulated CD pre-compensation or post-compensation configuration. The maximum achievable reach improvement of DWDM-PON system using proposed CD compensation methods and two different DCM unit positions (before and after SMF fiber span) have been investigated. The maximum reach of realized DWDM-PON system without CD compensation was 57 km, but it has been shown that using described CD compensation methods (DCF and FBG) system maximum reach can be improved.

By implementation of DCF fiber in DCM unit the 16 channel DWDM-PON system's maximal link length between OLT and ONT in pre-compensation configuration improved by 19.3% or 11 km in length – from 57 km to 68 km, but in post-compensation configuration by 5.3% or 3 km in length – from 57 km to 60 km.

The best results were obtained by using FBG for CD pre-compensation as well as for post-compensation. Using the FBG in DCM unit for CD pre-compensation DWDM passive optical network reach can be improved by 26.3% or extra 15 km in length – from 57 km to 72 km, but using FBG in post-compensation configuration network reach can be improved by 15.8% or extra 9 km in length – from 57 km to 66 km. Basis on the results we recommend to use FBG in DCM unit for CD compensation in pre-compensation configuration (before SMF fiber span) in future high speed long-reach DWDM-PON systems.

Acknowledgement

This work has been supported by the European Social Fund within the project «Support for the implementation of doctoral studies at Riga Technical University».

References

1. **Ivanovs G., Spolitis S.** Extending the Reach of DWDM-PON Access Network Using Chromatic Dispersion Compensation // 2011 IEEE Swedish Communication Technologies Workshop, Swe-CTW 2011. – No. 6082484. – P. 29–33.
2. **Cho K. Y., Takushima Y., and Chung Y. C.** Enhanced chromatic dispersion tolerance of 11-Gb/s RSOA-based WDM PON using 4-ary PAM signal // IET Electronics Letters, 2010. – Vol. 46. – No. 22. – P. 1510–1512.
3. **Darren P. Shea, John E. Mitchell.** Long-Reach Optical Access Technologies // IEEE Network, 2007. – Vol. 21. – No. 5. – P. 5–11.
4. **Hong U. H., Cho K. Y., Takushima Y., and Chung Y. C.** Maximum reach of long-reach RSOA-based WDM PON employing remote EDFA // Optical Fiber Communication Conference 2011. – Los Angeles, California, USA, 2011.
5. **Vukovic A., Savoie M., Hua H.** Performance Characterization of PON Technologies // International Conference on Application of Photonics Technology. – Photonics North, Ottawa, 2007.
6. **Bobrovs V., Spolitis S., Udalcovs A., Ivanovs G.** Schemes for Compensation of Chromatic Dispersion in Combined HDWDM Systems // Latvian Journal of Physics and Technical Sciences, 2011. – No. 48(5). – P. 30–44.
7. **Agrawal G.** Fiber – Optic Communication Systems. – USA: John Wiley and Sons, 2002. – 561 p. DOI: 10.1002/0471221147.
8. **Udalcovs A., Bobrovs V.** Investigation of Spectrally Efficient Transmission for Differently Modulated Optical Signals in Mixed Data Rates WDM Systems // IEEE Swedish Communication Technologies Workshop (Swe-CTW), 2011. – No. 6082493. – P. 7–12.
9. **Bobrovs V., Ivanovs G., Spolitis S.** Realization of Combined Chromatic Dispersion Compensation Methods in High Speed WDM Optical Transmission Systems // Electronics and Electrical Engineering. – Kaunas: Technologija, 2011. – No. 10(116). – P. 33–38. DOI: 10.5755/j01.eee.116.10.875.
10. **Bobrovs V., Ozoliņš O., Ivanovs G., Poriņš J.** Realization of HDWDM Transmission System // International Journal of Physical Sciences, 2010. – No. 5(5). – P. 452–458.

Received 2012 01 19

Accepted after revision 2012 03 09

S. Spolitis, V. Bobrovs, P. Gavars, G. Ivanovs. Comparison of Passive Chromatic Dispersion Compensation Techniques for Long Reach Dense WDM-PON System // Electronics and Electrical Engineering. – Kaunas: Technologija, 2012. – No. 6(122). – P. 65–70.

The maximum reach of the DWDM-PON system can be severely limited by chromatic dispersion (CD). This paper contains the investigation of long-reach high speed 16-channel DWDM-PON system with efficient CD pre-compensation and post-compensation methods. It is shown that CD compensation has a crucial role for guaranteed downstream optical link performance and maximum link length of high speed long-reach DWDM-PON system. The results show that usage of additional 7 km long dispersion compensating fiber (DCF) placed in central office (pre-compensation configuration) improves the DWDM-PON network reach by 19.3% (from 57 km up to 68 km), but if additional 2 km long DCF fiber is used in remote terminal (post-compensation configuration) link length can be extended up to 5.3% (from 57 km to 60 km). It was found that usage of fiber Bragg grating (FBG) in central office (pre-compensation configuration) improves network reach up to 26.3% (from 57 km up to 72 km), but using this FBG for CD post-compensation in remote terminal network reach can be improved by 15.8% or 9 km in length – from 57 km to 66 km. Basis on the results authors recommend to use FBG as the best solution for CD compensation in pre-compensation configuration (before SMF line) in future high speed long-reach DWDM-PON systems. Ill. 7, bibl. 10, tabl. 1 (in English; abstracts in English and Lithuanian).

S. Spolitis, V. Bobrovs, P. Gavars, G. Ivanovs. Pasyvios chromatinės dispersijos kompensavimo metodikos, skirtos tolumo pasiekiamumo WDM-PON sistemai palyginimas // Elektronika ir elektrotechnika. – Kaunas: Technologija, 2012. – Nr. 6(122). – P. 65–70.

Maksimalus DWDM-PON sistemos pasiekiamumas gali būti ribojamas chromatinės dispersijos (CD). Pateikiamas tolumo pasiekiamumo didelio greičio 16 kanalų DWDM-PON sistemos su efektyviais CD prekompensacijos ir postkompensacijos metodais tyrimas. Parodyta, kad CD kompensacija turi lemiamą įtaką maksimaliam ryšio ilgiui. Rezultatai rodo, kad, naudojant 7 km ilgio DC optinę skaidulą, pasiekiamumas padidėja DWDM-PON tinkle 19,3 % (nuo 57 km iki 68 km), bet, jei papildoma 2 km ilgio DC skaidula naudojama nutolusiame terminale (postkompensacijos konfigūracija), ryšio ilgis gali padidėti 5,3 % (nuo 57 km iki 60 km). Rekomenduojama naudoti FBG kaip geriausią CD kompensaciją prekompensacijos konfigūracijoje ateities tolumo pasiekiamumo DWDM-PON sistemoms. Il. 7, bibl. 10, lent. 1 (anglų kalba; santraukos anglų ir lietuvių k.).