

## Sizing of Electrical Motors for Gearless and Directly Stimulating Applications

**İ. Tarimer**

*Department of Electronics and Computer Education, Technical Education Faculty, Muğla University  
Kötekli Campus, 48000, Muğla, Turkey, phone: +90 252 211 1722, e-mail: itarimer@mu.edu.tr*

**R. Gurbuz**

*Manufacturing Department of Technical and Business College, Cankiri Karatekin University  
Meslek Yuksekokulu 18200, Cankiri, Turkey, phone: + 90376211582-126 e-mail: gurbuz@cmyo.ankara.edu.tr*

### Introduction

Types of materials used in its production, nub, height and body diameter of it, its revolution number, its values of efficiency and power are important physical and electrical parameters taken into consideration in the design of a motor. Another important factor whether the design developed is applicable or not, should be determined before the production.

Electrical motors apart from the brushed DC motors are usually designed and produced in such a way as to function at high speeds [1, 2]. Gürdal states that in order to be able to get enough power and torque from the motors, they should be operated at rated value [3]. When the electrical motors located in some industrial equipment are operated together with mechanical redactors attached, it is known that they produce high torque [4, 5]. Use of various household tools and some industrial machines together with redactors increases the size and volume of unified unite. The efficiency of the motors found in such mechanisms decreases.

Huang and his associates produced some general approaches in their designs [6]. Hwang and Chang developed a DC motor with high power for electrical vehicles [7]. Rahman and his colleagues realized the design and control of an SR motor with 6/4 and 8/6 poles and high speed that can be used in electrical vehicles [8]. Ramamurthy and Balda sized an SR motor for electrical vehicles [9]. Hall and his colleagues realized multi – phased stimulated SR motor analyses and size measurements [10]. Kalokiris and Kladas offered a design methodology for higher efficiency actuators [11].

In this study, designs of brushed DC, brushless DC and SR motors with high torque, small size and that can work in low speed were developed [2]. The motors designed here are suggested as alternative to be used in mechanical systems without reductor.

### Speed-Momentum Relation in an Electrical Motor Actuated with a Reductor

The use of electrical motors with gears in house utensils such as kitchen robots, washing machines, flour grinders, mincing machines and some industrial equipment is essential in terms of the nature of the work done. In such places the devices are required to work at low speed but high torque. Usually in mechanism operated together with geared reductor, asynchronous motors and brushed / brushless DC electrical motors are used. Therefore, the speed and its relation with the torque of the motor which is actuated with reductor and which is with 3-phased, four-poled, 0.05 sliding and 1.5 HP were investigated. Such a motor is operated in the mechanism shown in Fig. 1 and loaded with a DC motor. This motor is driven at low speeds with a vector inverter; speed-torque relation was examined.

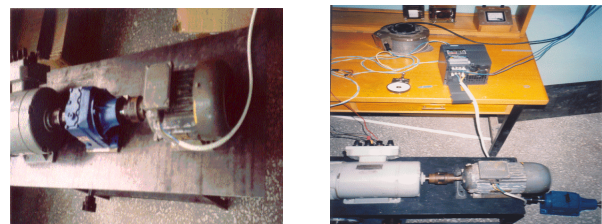

**Fig. 1.** Experimental mechanisms of 3 phased 1.5 HP motor which is operated with both reductor and inverter

The frequency of the motor used in the experiments conducted with the mechanisms seen in figure 1 ranges from 0.2 and 6 Hz and its voltage ranges from 19.5 V and 40.2 V; on the other hand, it is observed that the number of revolution ranges from 5 rpm to 172 rpm. In this study, the values of the motor current were measured to be between 0.25 A and 7.2 A. During the experiment, while the inverter decreases the circulation of motor, the  $V/f$  value is kept

constant. The amount of magnetic flux induced in the motor is calculated with the following equation.

$$\phi = \frac{E_s}{4,44 \times K_w \times N_s \times f_s}, \quad (1)$$

where  $E_s$  is voltage to have applied to motor in the experiment,  $K_w$  is a constant depending on physical values in the motor,  $N_s$  revolution per minute and  $f$  is frequency.

In the experiment conducted, due to the operating style of inverter, when the  $V/f$  ratio is kept constant, it will be seen that at low speeds, there will be the generation of magnetic flux and accordingly the generation of torque. Therefore, in the experiment carried out with a motor operated with an inverter, the speed of the asynchronous motor cannot be decreased lower than 143 rpm. On the other hand, during the experimental work, by combining a reductor with 10:1 conversion ratio to this motor, unified system can be operated at the speed of 143 rpm. The torque value provided by this motor without being connected to the reductor and torque value ( $T_2$ ) at the reductor exit produced when a reductor is combined are obtained from the (2).

$$T_1 = \frac{P \times 746}{[n_1(1-0,050)] \times \frac{2\pi}{60}}, \quad (2)$$

where  $P$  is output power to have applied to motor in the experiment,  $N_1, N_2$  are the speeds of 1500 and 143 rpm and 746 is constant value.  $T_1$  and  $T_2$  are calculated from equation 2 as  $T_1=7.3$  and  $T_2=73 Nm$ .

In the experiment conducted by feeding AC motor with inverter and by combining reductor to its shaft, the speed-torque values obtained by increasing the speed of motor from 143 rpm to rated speed are estimated as seen in Table 1. The results are plotted in Fig. 2.

**Table 1.** Rated speed

Speed (rpm)	Momentum (Nm)
143	17.1324
145	17.6519
150	26.6386
155	27.4651
160	27.7533
165	31.9979
170	39.17
175	41.1634
180	42.9864
185	44.6218
190	48.2569
195	50.3955
200	53.8883
250	73.3987
1460	97.7131

When the asynchronous motor used in the experiment is operated by being fed from the inverter, it produces low momentum ranging from 143 rpm to 175 rpm speeds. However, while the motor is operating at rated revolution, its momentum increases to 7.3 Nm value. When the motor

is operated by combining reductor to its shaft, its speed becomes 143 rpm and its momentum becomes 73 Nm. In that case, ten-fold difference is observed between the operation performed only through inverter feeding and the operation performed in combination with reductor fed from the inverter. From that point of departure, it is suggested that for a motor to be operated at low circulation with high momentum, motor designs that can generate high momentum at low circulation with the smallest possible volume should be developed.

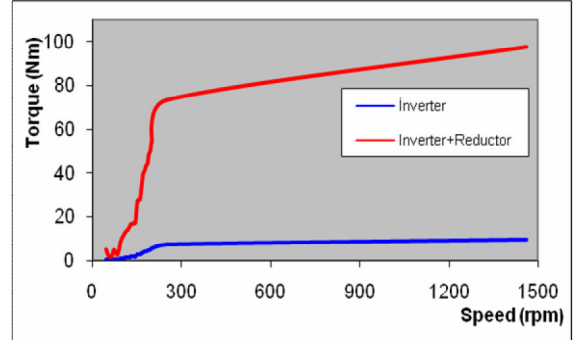

**Fig. 2.** Torque-speed curves obtained from operating the motor by feeding AC motor with inverter and by combining reductor to its shaft

## DC And SR Motor Design Equations for Actuation Applications

In this section, basic equations required for DC and SR motor designs used in actuation systems are given. Power, output and momentum equations of a DC machine are given [2]:

$$P_a = C_o D^2 l n, \quad (3)$$

$$C_o = \pi^2 B_{ort} ac \times 10^{-3}, \quad (4)$$

$$T = \frac{P_a}{\omega_r} = \left( \frac{\pi}{2} B_{ort} ac \right) D^2 l \quad (Nm). \quad (5)$$

The number of armature conductors of a DC machine is ( $Z$ ) and the cross sectional area of armature conductor is calculated as:

$$Z = \frac{E_a}{\phi n p}, \quad (6)$$

$$a_z = \frac{I_z}{J}. \quad (7)$$

Armature resistance of a DC machine, shunt field coil resistance and commutation field coil resistance are given:

$$R_a = \frac{Z}{2 \times a^2} \times \frac{\rho \cdot l_{ma}}{a_z \times 10^{-6}} \quad (\Omega), \quad (8)$$

$$R_f = \frac{V_f}{I_f} = n \times N_f \times \frac{\rho l_{fc}}{k_{fc} \times 10^{-6}} \quad (\Omega), \quad (9)$$

$$R_{ip} = \frac{\rho \times l_{ic} \times N_{ip}}{k_{ia} \times 10^{-6}} \times p \quad (\Omega). \quad (10)$$

Armature copper loss of a DC machine, copper loss of commutation area coil and copper loss of shunt area are given:

$$\begin{cases} P_{cu} = I_a^2 \times R_a, \\ P_i = I_a^2 \times R_{ip}, \\ P_f = I_f^2 \times R_f. \end{cases} \quad (11)$$

Basic equations valid in the design of a switched reluctance motor thought to be used in direct brushless actuation systems are given in (12–16). Average torque of an SR motor value is given:

$$T = C_o \times D_r^2 \times l_{stk} \quad (Nm). \quad (12)$$

Air gap of a switched reluctance motor can be as low as 0.1 mm to decrease the acoustic noise to lowest level and to maintain balanced phase flux. If stator length/diameter ratio is 1, air gap is taken as 0.5 of rotor diameter [3].

Net electromagnetic volume of a switched reluctance motor is determined by iron sheet package diameter of stator ( $D_s$ ) and axial length of outer edges of coil ends ( $l_e$ ). Length value taken from coil ends from one outer end to another end is given

$$l_e = l_{stk} + 2 \cdot l_h. \quad (13)$$

Net electromagnetic volume values of SR motor is:

$$v = D_s \times l_{stk} \quad (m^3). \quad (14)$$

In an SR motor, an appropriate air gap is required to maintain balanced phase fluid and to decrease the acoustic noise to the possible lowest degree. Hence, if the stator ratio of length/diameter is 1, air gap is taken as 0.5 of the rotor diameter [3]. Polar widths and stator chamfer depth of an SR motor are given:

$$\begin{cases} t_s = 2 \times (r_1 + g) \times \sin \frac{\beta_s}{2}, \\ t_r = 2 \frac{D_r}{2} \left( \sin \frac{\beta_r}{2} \right). \end{cases} \quad (15)$$

$$d_s = \frac{(D_s - D_r - 2 \times (g + y_s))}{2}. \quad (16)$$

### DC And SR Motor Designs With Low Speed And High Torque

First, physical and electrical parameters of a brushed DC, a brushless DC and a SR motor having the same power and rated revolution are calculated through (17-22) and Ansoft RMxprt electromagnetic design program; the results obtained are analyzed. Physical and mechanical measurements and electrical and some magnetic parameters related to the motors are obtained from the designs.

### The Design Of A Brushed DC Motor

A brushed DC motor with 1.5 kW, 110 V, 150 rpm permanent magnet was designed with the help of Ansoft RMxprt program. In Fig. 3, the screen view of the program through which a brushed DC motor with 1.5 kW, 110 V, 150 rpm permanent magnet was designed, in Fig. 4, iron sheet package structure of the designed motor is seen. In

Table 2, obtained physical measures, and mechanical measures and some electrical parameters are given.

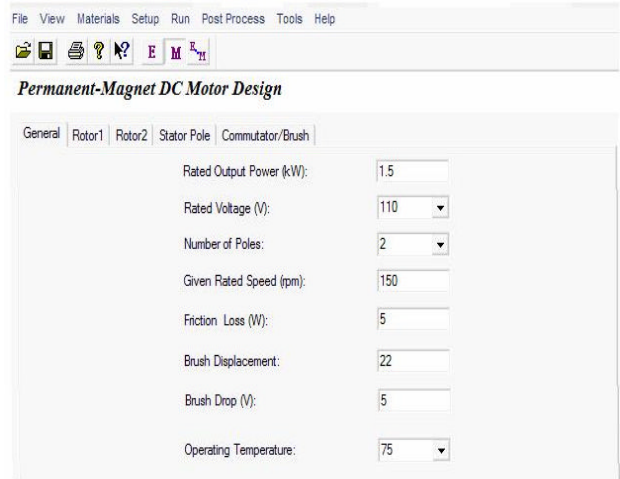

Fig. 3. Analytic design program window of brushed DC motor with 1.5 kW, 110 V, 150 rpm permanent magnet

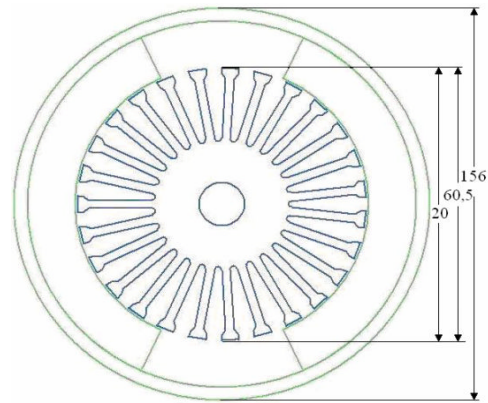

Fig. 4. Iron sheet package view of brushed DC motor with 1.5 kW, 150 rpm permanent magnet

Table 2. Physical measures

Geometrical Dimensions and Electrical Values	
The revolution per minute ( <i>rpm</i> )	150
Rated output power ( <i>kW</i> )	1.5
Number of poles	4
Rated voltages ( <i>V</i> )	110
Loss caused by friction and wind ( <i>W</i> )	10
Voltage drop at the pair of brushes ( <i>V</i> )	5
Insulation thickness of rotor slot ( <i>mm</i> )	0.5
The number of rotor slots	27
Inside diameter of rotor ( <i>mm</i> )	40
The length of rotor armature ( <i>mm</i> )	199
The diameter of commutator ( <i>mm</i> )	28
Inner diameter of stator $D_{si}$ ( <i>mm</i> )	60
Air gap between rotor and stator ( <i>mm</i> )	0.5
Outer diameter of stator $D_{so}$ ( <i>mm</i> )	156
Momentum (Torque), $T$ ( <i>Nm</i> )	18.862
Efficiency, $\eta$ (%)	84.051

Volume of 150 rpm brushed DC motor is obtained from (17).

$$v_1 = \pi \times \frac{D_1^2}{4} \times l_1, \quad (17)$$

$$v_1 = \frac{(0,156)^2}{4} \times 0,199 \times 3,14 = 3,8016482 \times 10^{-3} m.$$

This DC motor produces 18.862 Nm torque at 150 rpm speed. Iron sheet package area of the motor is obtained from (18).

$$A_1 = \pi \times \frac{D_1^2}{4}, \quad (18)$$

$$A_1 = 3,14 \times \frac{(0,156)^2}{4} = 0,01910376 m^2.$$

### The Design of a Brushless DC Motor

The design of 11.5 kW, 110 V, 150 rpm permanent magnet brushless DC motor was developed in RMXprt electromagnetic design program. In Fig. 5, screen view of the program where the design of 1.5 kW, 110 V, 150 rpm permanent magnet brushless DC motor was developed, in Fig. 6, iron sheet package program of designed motor and in Table 3, obtained physical and mechanical measurements and electrical parameters are given.

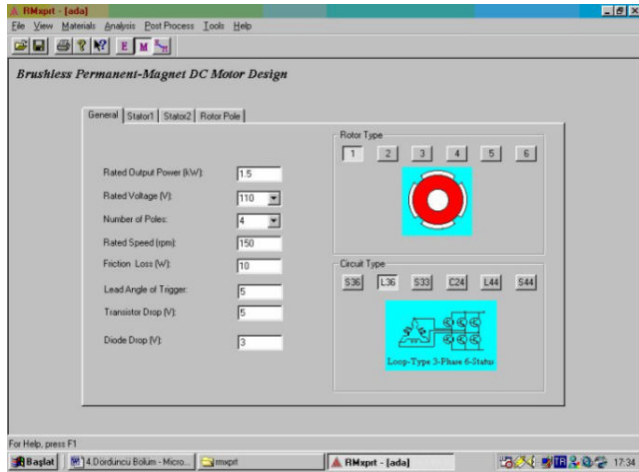

Fig. 5. Program window to which general information related to brushless permanent magnet DC motor is entered

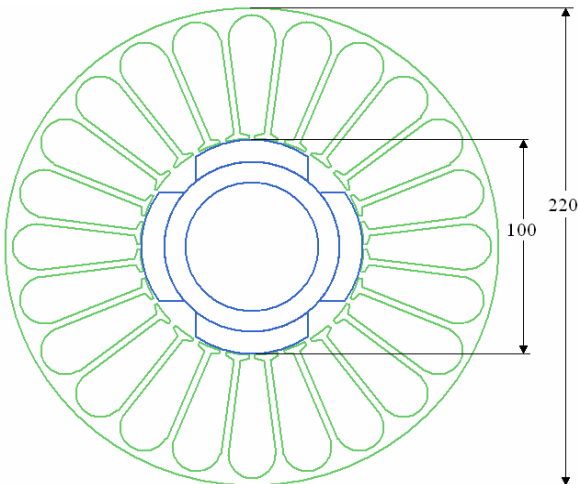

Fig. 6. Iron sheet package view of brushless permanent magnet DC motor

Table 3. Electrical parameters

Geometrical Dimensions and Electrical Values	
The number of circulation ( <i>rpm</i> )	150
Rated output power ( <i>kW</i> )	1.5
Number of poles	4
Rated voltages ( <i>V</i> )	110
Loss caused by friction and wind ( <i>W</i> )	10
The length of stator armature ( <i>mm</i> )	155
Inner diameter of stator $D_{st}$ ( <i>mm</i> )	60
Outer diameter of rotor $D_{so}$ ( <i>mm</i> )	59.5
The number of stator slots	24
Inside diameter of rotor ( <i>mm</i> )	40
Stator outer diameter $D_{so}$ ( <i>mm</i> )	220
Momentum, T ( <i>Nm</i> )	14.763
Efficiency, $\eta$ (%)	87.52

The volume of 150 rpm brushless DC motor is obtained from (19).

$$v_2 = \frac{(0,220)^2}{4} \times 0,155 \times 3,14 = 5,88907 \times 10^{-3} m^3. \quad (19)$$

This DC motor produces 14.763 Nm torque at 150 rpm speed. Iron sheet package area of the motor is obtained from (20).

$$A_2 = \pi \times \frac{D_2^2}{4}, \quad (20)$$

$$A_2 = 3,14 \times \frac{(0,220)^2}{4} = 0,038 m^2.$$

The power of this motor designed to operate at 150 rpm speed at 150 rpm is about 1500 W. As the losses of the motor increase at lower speeds, it produces low output power. While the output power of the motor increases proportionally with its speed, the efficiency of the motor increases parallel to its speed. The speed value of 150 rpm which was assumed to be reached during the design processes is reached with 87.52% efficiency. In order for the motor to produce high torque at speeds lower than 150 rpm, its sizes should be enlarged.

### The Design of an SR Motor

In this section, the design of 1.5 kW, 380 V, 150 rpm, 8/6 pole SR motor is developed in an electromagnetic design program. When the number of the poles is high, the cost of sliding mechanisms of SR motor increases. Therefore, an SR motor with 8/6 poles is designed. The screen view of the program where this design is realized is seen in Fig. 7, iron sheet package view of the designed 8/6 poled motor is seen in figure 8 and geometrical dimensions and mechanical measurements and electrical parameters are given in Table 4.

In Fig. 7, screen view of the program where the design of 1.5 kW, 380 V, 150 rpm, 8/6 pole SR motor was developed, in Fig. 8, iron sheet package program of designed 8/6 pole motor and in table 3, obtained physical

and mechanical measurements and electrical parameters are given.

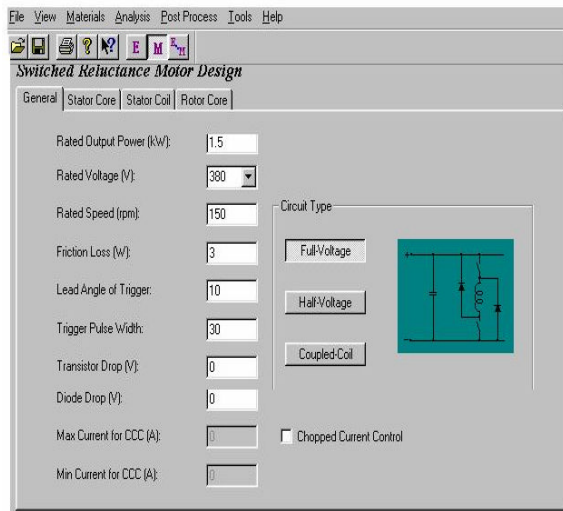

Fig. 7. The window of the program where general information related to 150 rpm, 8/6 pole SR motor is entered.

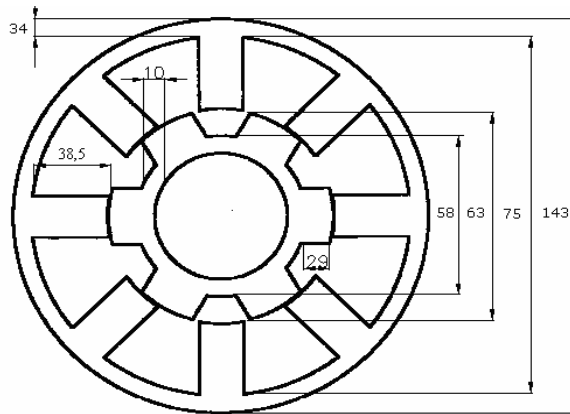

Fig. 8. Iron sheet package view and measurements (mm) of a 1.5 kW, 380 V, 150 rpm, 8/6 pole SR motor.

Table 4. Physical measures

Geometrical Dimensions and Electrical Values	
Number of revolution (rpm)	150
Rated output power (kW)	1.5
Number of poles	8/6
Rated voltages (V)	380
Air gap between rotor and stator (mm)	0.4
The length of rotor (mm)	174
Efficiency, $\eta$ (%)	86.893
The length of stator armature l (mm)	186
Stator outside diameter, $D_{so}$ (mm)	143
Stator inner diameter, $D_{si}$ (mm)	75
The height of stator harness (mm)	38.5
The thickness of stator and rotor harness	10
The height of rotor harness (mm)	29
Rotor outer diameter (mm)	63
Momentum (Torque), $T$ (Nm)	10.788

The volume of 150 rpm motor with 8/6 poles is obtained from Eq. 21.

$$v_3 = \pi \times \frac{D_3^2}{4} \times l = \frac{(0,143)^2}{4} \times 0,186 \times 3,14, \quad (21)$$

$$v_3 = 2,9857585 \times 10^{-3} m^3.$$

An 8/6 SR motor produces 10.788 Nm torque at 150 rpm speed. The iron sheet area of the SR motor with 8/6 poles is obtained from (22).

$$A_3 = \pi \times \frac{D^2}{4} = 3,14 \times \frac{(0,143)^2}{4} = 0,016052465 m^2 \quad (22)$$

### The Comparison of the Results Obtained

In Table 5, the comparisons of stator diameters and stator armature lengths of brushed and brushless DC and SR motors are presented. In Table 6, comparisons of motor values are obtained from the designs developed according to 150 rpm. In Table 7, comparisons of iron sheet package areas of brushed and brushless DC and SR motors can be seen.

Table 5. Stator Diameters

Revolution per minute (rpm)	Stator Diameters, $D$ (mm)			Stator Armature lengths, $l$ (mm)		
	Brushed DC	Brushless DC	8/6 SRM	Brushed DC	Brushless DC	8/6 SRM
150	56	220	143	199	155	186

Table 6. Motor Volumes

Revolution Per minute (rpm)	Motor Volumes, $V$ ( $m^3$ )		
	Brushed DC	Brushless DC	8/6 SRM
150	3.8016482 $\times 10^{-3}$	5.88907* $10^{-3}$	2.9855785* $10^{-3}$

Table 7. Iron sheet package areas

Revolution Per minute (rpm)	Iron sheet package areas, $A$ ( $m^2$ )		
	Brushed DC	Brushless DC	8/6 SRM
150	0.01910376	0.038	0.016052465

In the designs developed for 150 rpm speed, the efficiency of brushed DC motor was found to be 84.051% and its torque 18.862 Nm; the efficiency of brushless motor was found to be 87.52% and its torque 14.763 Nm, and the efficiency of 8/6 SR motor was obtained to be 86.893% and its torque 10.788 Nm. At speed 150 rpm, brushed DC motor, brushless DC motor and 8/6 SR motor produce high torque with high efficiency values. At 150

*rpm* speed, stator diameter of brushed DC and 8/6 SR motor was obtained to be less than that of the brushless. Moreover at this speed value, armature lengths of 8/6 SR motor and brushless DC motor were designed to be less than that of the brushed DC motor. In the designs developed for 150 *rpm* speed, the volume of 8/6 SR motor is less than those of other two designs.

### Conclusions and Suggestions

In the motor designs developed, it was observed that brushed and brushless permanent magnet DC and SR motors provide high efficiency and torque at low speeds. In this respect, as brushed DC motor generates 18.862 *Nm* momentum with 84.051% efficiency, brushless DC motor produces 14.763 *Nm* with 87.52% and 8/6 SR motor generates 10.788 *Nm* torque with 86.893% efficiency, they are appropriate to operate for 150 *rpm* speed. Moreover, the volumes of the designed motors were obtained to be  $3.8 \times 10^{-3}$ ,  $5.89 \times 10^{-3}$  and  $2.98 \times 10^{-3}$  m<sup>3</sup>. In this study, it is suggested that the designed brushed/brushless DC and 8/6 SR motors should be used as an alternative in mechanical systems without reductor.

### References

1. **Bhag S.G., Hizirolu H.**, "Electrical Machines", USA.
2. **Tarimer I.**, "Low Speed High Torque Electrical Motor Designs for Reductorless Mechanical Systems", PhD Thesis, *Gazi University*, (2003).
3. **Gürdal O.**, "Design of Electrical Machines", ISBN 975-6574-07-0, Nobel Publishing House, September 2001, Ankara.
6. **Huang, S., Luo J., Leonardi F., Lipo T.A.**, "General Approach to Sizing and Power Density Equations for Comparison of Electrical Machines", 1998, IEEE Transactions on Industry Applications, Vol.34, No. 1, January/February 1998.
7. **Hwang, .C.C., Chang, J.J.**, "Design and analysis of a high power density and high efficiency permanent magnet DC motor", 2000, Journal of Magnetism and Magnetic Materials 209 (2000), p-p 234-236.
8. **Rahman K.M., Fahimi B., Suresh G., Rajarathnam A.V.**, "Advantages of Switched Reluctance Motor Applications to EV and HEV: Design and Control Issues", 2000, IEEE Transactions on Industry Applications, Vol.36, No.1, January/February 2000.
9. **Ramamurthy S.S., Balda J.C.**, "Sizing a Switched Reluctance Motor for Electric Vehicles", 2001, IEEE Transactions on Industry Applications, Vol.37, No.5, September/October 2001.
10. **Hall E.M., Ramamurthy S.S.**, "Analysis, Dimensional Sizing and Configuration Comparison of Switched-Reluctance Motors Operating Under Multiphase Excitation", 2002, IEEE Transactions on Energy Conversion, Vol. 17, No.3, September 2002.
11. **Kalokiris G., Kladas A.**, "New magnetic material impact in electric machine design high speed operation and reduction of losses", 2003, Elsevier, Sensors and Actuators A 106 (2003), P. 292–297.

Submitted for publication 2007 11 16

### **I. Tarimer, R. Gurbuz. Sizing of Electrical Motors for Gearless and Directly Stimulating Applications // Electronics and Electrical Engineering. – Kaunas: Technologija, 2008. – No. 4(84). – P. 21–26.**

Electrical machines are usually designed and produced to work at high circulation. The machines that are designed to work at high circulation are used along with reducers to be operated at low speed mechanisms to acquire high torque. In this study, brushed/brushless DC and SR motor designs with low speed and high torque were developed. According to the designs obtained, the motors were sized and compared to each other. The electrical motors sized in this study are suggested to be used for some household utensils and some work machines without reductor. Ill. 8, tabl. 7, bibl. 11 (in English; summaries in English, Russian and Lithuanian).

### **И. Таример, Р. Гурбуз. Уменьшения электрических двигателей для механизмов и непосредственно стимулирования заявлений // Электроника и электротехника. – Каунас: Технология, 2008. – № 4(84). – С. 21–26.**

Электрические машины обычно разрабатываются и производятся, чтобы работать над высоким обращением. Машины, которые разработаны, чтобы работать над высоким обращением, используются наряду с редукторами, который управляется в механизмах низкой скорости, чтобы приобрести высоко вращающий момент. В этом исследовании, были развиты постоянный ток и проекты двигателя эсера с низкой скоростью и высоким вращающим моментом. Согласно полученным проектам, двигатели были измерены и друг по сравнению с другом. Электрическим двигателям, измеренным в этом исследовании предлагают использоваться для некоторой домашней посуды и некоторых машин работы без редуктора. Ил. 8, табл. 7, библи. 11 (на английском языке; рефераты на английском, русском и литовском яз.).

### **I. Tarimer, R. Gurbuz. Mažinimas elektrinių variklių mechanizmams ir tiesiogiai veikiančioms grandims // Elektronika ir elektrotechnika. – Kaunas: Technologija, 2008. – Nr. 4(84). – P. 21–26.**

Elektrinės mašinos yra paprastai projektuojamos ir gaminamos taip, kad veiktų dideliais sūkais. Mažo greičio mechanizmuose tokios mašinos naudojamos su reduktoriais. Iširti DC ir CR tipo varikliai, turintys maža greitį ir didelį sukimo momentą. Remiantis gautais rezultatais varikliai buvo suskirstyti pagal dydį ir palyginti vienas su kitu. Iširtus elektros variklius rekomenduojama naudoti kai kuriuose buitiniuose prietaisuose ir kai kuriose mašinose darbui reduktorių. Il. 8, lent. 7, bibl. 11 (anglų k.; santraukos anglų, rusų ir lietuvių k.).

DOI: 10.5755/j02.eie.11114