

## The Fibre-Optic System Detecting the Burning Mazout in Power Boilers

W. Wójcik, A. Kotyra, M. Duk

*Department of Electronics, Technical University of Lublin*

*Nadbystrzycka 38a, 20-618 Lublin, Poland, e-mail: komada@poczta.onet.pl*

T. Golec

*Institute of Power Industry, Augustówka 5, 02-981 Warsaw, Poland*

### Introduction

Effective combustion in power conditions, except decreasing the emission of harmful substances into the atmosphere, also improves the safety of industrial boiler operation. One of the most critical moments of power boiler operation is the starting up phase. It begins with switching on an auxiliary gas lighters and goes on up to the reaching boiler's optimal heat parameters. Typically, in the case of considered boiler type (OP650), it takes about eight hours.

The starting up phase of the mentioned boiler can be divided into several stages. In the first stage, gas lighters placed inside coal burners are switched on. In the second stage, gas burners light mazout, and they are shut down. Then, the only working burners are the mazout ones. If temperature inside the combustion chamber of the boiler reaches the proper level, pulverised coal – air mixture is delivered to coal burners and the mixture lights. Mazout

and coal – air mixture are burning simultaneously, the temperature inside the combustion chamber is still growing. Eventually, the mazout burners can be shut down, and the only fuel being burned is pulverised coal. Occasionally, some of the mazout burners can be switched on only if there is a need to change or to stabilise the operation point of the boiler.

To ensure a better control over power boiler, especially during its starting up phase, there is a need to obtain information about the kind of fuel, that currently burns. The problem of distinction of the burned fuel arises from coaxial location of mazout and pulverised coal burners, which are shown on Fig.1. Mazout flame emits radiation, which is strongly absorbed by surrounding carbon particles. Thus, conventional flame sensors placed aside of the burner can not properly detect mazout flame. Moreover, to be based only on amplitude measures of flame radiation, it is difficult to recognise the burned fuel due to variable coal constitution.

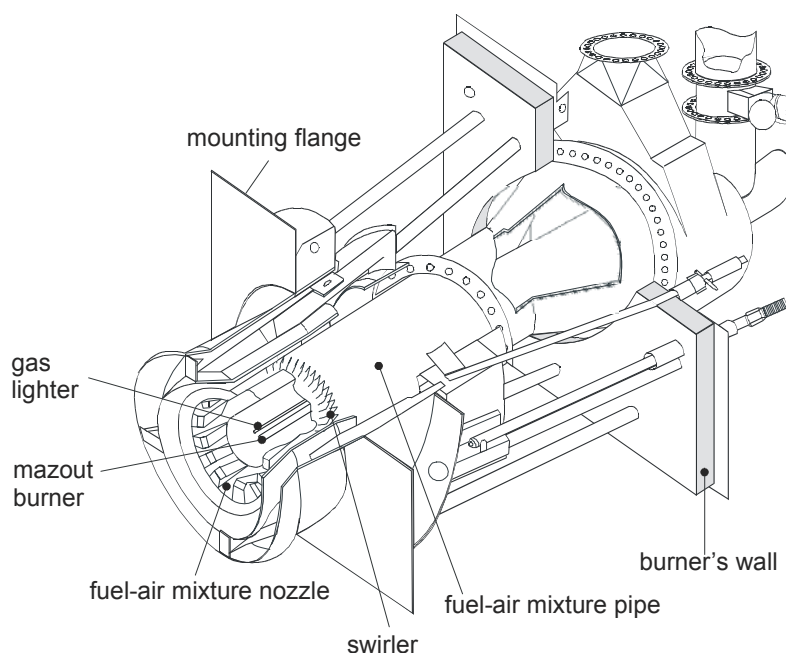

Fig. 1. Pulverised-coal burner with location of mazout burner

Other difficulty is that probe's end might get dirty which affects the level of the output signal. It made the authors to seek other analysing methods, which would be more resistant to the mentioned above disturbing factors. The above reasons forced to utilise frequency measures of a signal. Turbulence of mazout flame affects its surroundings, which can be detected by sophisticated methods.

The aim of the research was to find appropriate method, which would detect change in the composition of the fuel being burned. We have utilised wavelet transform of a signal corresponding to flame radiation intensity. The signal is obtained through flame monitoring system that was developed at Dept. of Electronics, Lublin Univ. of Technology. The multichannel, fibre-optic probe, which is the key part of the system, enables far better spatial resolution of measurements comparing with the other solutions and is specially designed to work in harsh conditions.

### Fiber-optic flame monitoring system

The velocity of a coal-air mixture outflow, particularly in the case of industrial burners is high enough, that it produces turbulent flow and turbulent combustion appearing at burners' outlet. The authors have carried out research works that enable characterising such kind of combustion through a flame pulsation. It has led to elaborate the method of distinction the kind of fuel to be burned. It can be based on analysing the signals, which correspond to variation of flame radiation [1].

The probe can observe the pulverised coal flame at a few zones (Fig. 2). Optical signal that contains information of the combustion process in particular zone is conducted via high temperature optical fibre to a detector, where it is converted into electrical signals (pulsation and flame intensity). It enables to place an electronic part of the whole device in a comparatively low temperature and to reduce the dimensions of the probe.

Application of fibre optics has enabled to place the electronic part of the device at comparatively low temperature. It has also made it possible to decrease the probe dimensions to the required minimum. In the case

being considered, the combustion process is unstable itself [2]. Detection of the signal features, that testifies the kind of burned fuel makes to use the methods, which enable concurrent analysing of the signal being considered both in time and frequency domain. Such a condition is fulfilled by wavelet based analyses [3], [4].

### Wavelet transform

Wavelet transform becomes more and more popular signal processing technique as opposed to Fourier transform. It decomposes finite energy signal  $f(t)$  into a series of wavelet coefficients  $\gamma(s, \tau)$  [3], [2]:

$$\gamma(s, \tau) = \int f(t) \cdot \overline{\psi_{s, \tau}(t)} dt, \quad (1)$$

where:  $\psi_{s, \tau}(t)$  – the set of base functions called wavelets;  $s$ ,  $\tau$  – scale and translation coefficients respectively  $t$  – time.

The elements of the set of base functions  $\psi_{s, \tau}(t)$  are obtained from a single prototype function by its continuous dilation and translation in time domain:

$$\psi_{s, \tau}(t) = \frac{1}{\sqrt{s}} \psi\left(\frac{t - \tau}{s}\right). \quad (2)$$

As opposed to Fourier transform, wavelet transform can represent a signal in time domain simultaneously at different resolutions. Moreover, the prototype function can be any function. However, it should have good localisation in time (which means vanishing at  $t \rightarrow \pm\infty$  and vanishing of its Fourier transform at  $\omega \rightarrow \infty$  and  $\omega \rightarrow 0$ ). Wavelet must fulfil admissibility condition [3]:

$$\int \frac{|\Psi(\omega)|^2}{\omega} d\omega < +\infty, \quad (3)$$

where:  $\Psi(\omega)$  is the Fourier transform of  $\psi_{s, \tau}(t)$ .

The admissibility condition is necessary condition for existence of the inverse transform. Because wavelet has a good localisation in time and frequency domain, from eq. (3) it follows that function  $\psi(t)$  has at least few oscillations. Thus, the word “wavelet” means just a “small wave”. Some of Daubechies wavelets are drawn on Fig. 3.

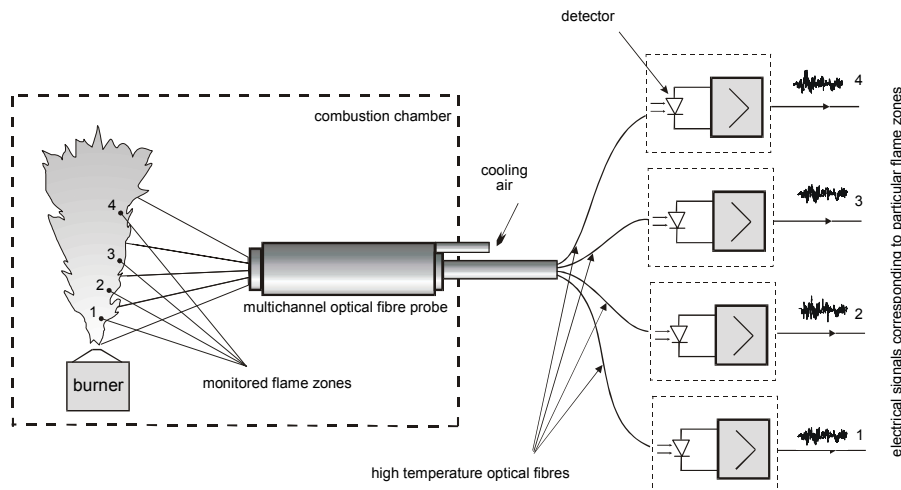
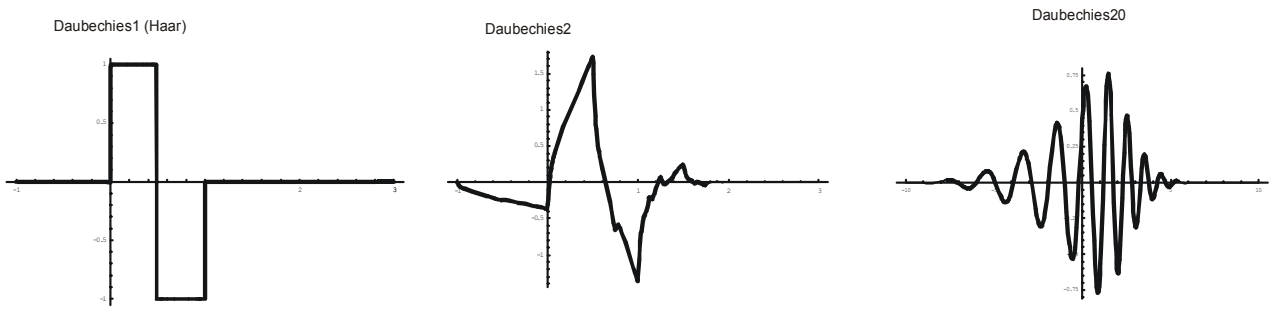

Fig. 2. Block diagram of flame monitoring system



**Fig. 3.** Daubechies wavelets of various orders

Practical realisation of transform in meaning of eq. (1), would be impossible due to continuity. Thus coefficients  $s$  and  $\tau$  should be discrete. For the sake of optimisation, it is convenient to set these coefficients (as it does in the case of Fast Fourier transform) as follows [3], [4]:

$$s = 2^j, \tau = i, \quad (4)$$

where  $i, j$  are integers, and to set the number of samples  $N$  to be integral multiple of power of 2. This leads to  $\log_2 N$  scale levels.

The signal can be reconstructed through the inverse wavelet transform, which is (in the discrete case) sum of base functions weighted by corresponding wavelet coefficients:

$$f(t) = \sum_{j,i} \gamma(j,i) \psi_{j,i}(t), \quad (5)$$

where:  $\gamma(j,i)$  – wavelet coefficients series.

### Research results

All measurements were done at “Kozienice” Power Plant (OP-650 boiler type, equipped with low-emission burners) using the flame monitoring system. The signals corresponding to amplitude variation of flame radiation intensity were recorded by the use of PC equipped with data acquisition board. An example signal (65536 samples acquired at 1kHz) reveals the qualitative change of burned fuel is shown on Fig. 4. Initially, only the mazout was

burned. After an instant pointed on Fig. 4 by the arrow, both mazout and pulverised coal are burned.

We did both continuous and discrete wavelet transforms over the example signal. To compute continuous transform means to calculate wavelet coefficient at any (but not all) value of scale and translation. If real signals are analyzed, they should be sampled relatively at high frequencies comparing to their bandwidth. That was in the case being considered. As opposed to the discrete wavelet transform, its continuous form contains redundant information of the signal. Thus, it is more convenient to find transients of the signal at a time-scale plane.

The graphical representation of continuous wavelet transform is a scalogram. Continuous wavelet transform was computed for the signal under consideration and its scalogram is shown on Fig. 5 with Daubechies4 as an analysing wavelet. Dark colours are corresponded to higher absolute values of wavelet coefficients and point to higher energy connected with particular point at the time scale plane. Signal details (high frequency components of the signal) are depicted in the upper part of scalogram while the low-frequency components are placed at the bottom. To be based on scalograms, one can learn variability of frequency structure of a signal. High-frequency (scale) components occur (shown with arrows), when the change of fuel constitution takes place, together with low-frequency ones. It is the typical pattern of scalogram, which points that pulverised coal is lighted with burning mazout.

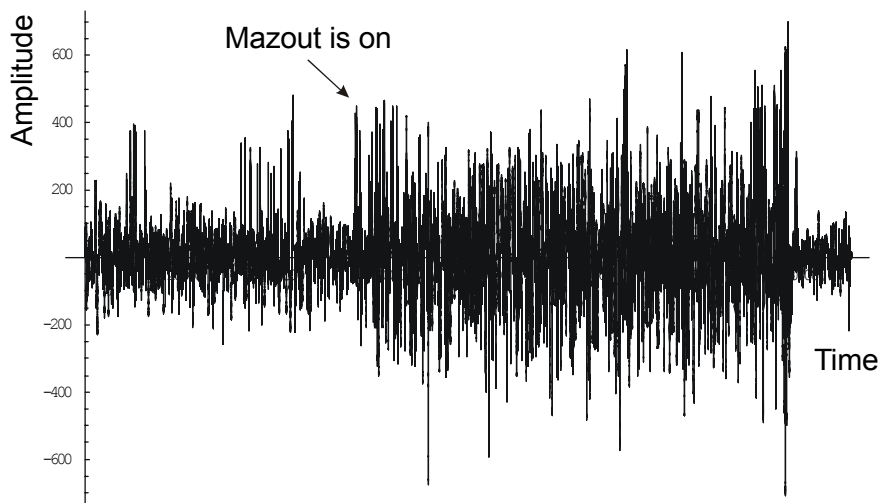

**Fig. 4.** Signal of flame pulsation showing the change of burned fuel

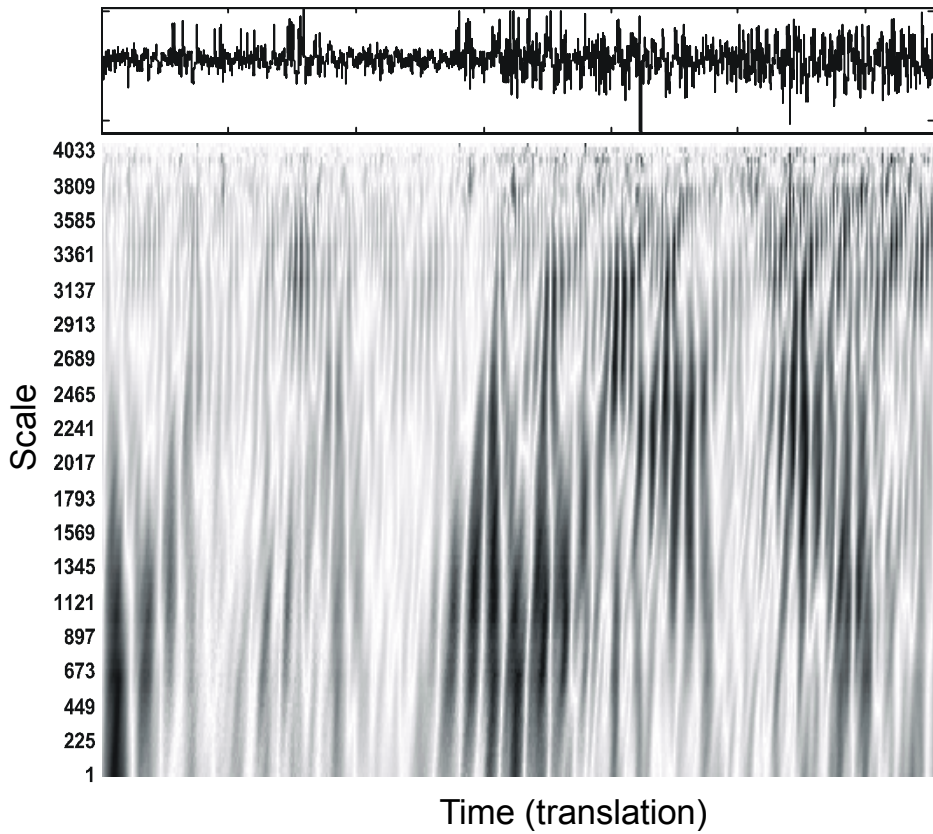

**Fig. 5.** Scalogram of continuous wavelet transform together with signal being analysed

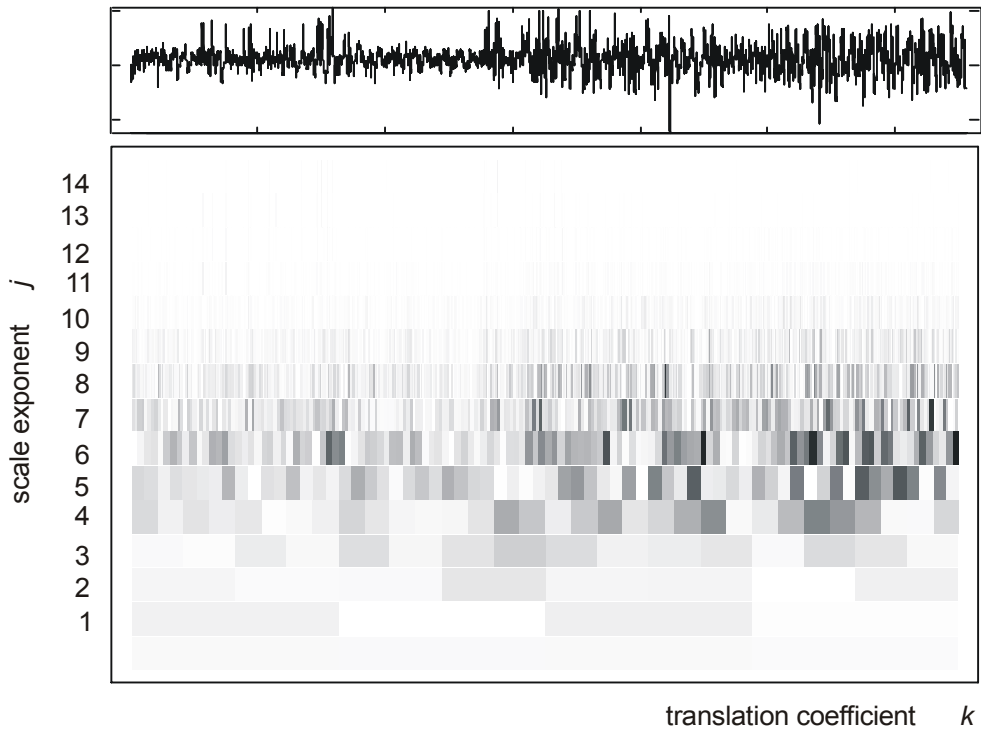

**Fig. 6.** Scalogram of discrete wavelet transform together with signal being analysed

The same signal was analysed using the discrete wavelet transform (Daubechies4). The resulting scalogram is presented at Fig. 6. To make the scalogram more legible, vertical axis is drawn at logarithmic scale. Rectangles

occurring at the scalogram correspond to discrete time – frequency (scale) localisation of particular events in the signal. The darker colour of rectangle is, the more energy it contains (as it does in the case of continuous wavelet

transform). All rectangles drawn in linear scale have an equal area.

Discrete wavelet transform detects the change of burned fuel as a presence of high-frequency components, detected at scales  $2^6 - 2^8$ . These scales, which correspond to appropriate frequency ranges with adequate time localisation, are the most sensitive to the proceeding change in combustion process.

Because of high computational power required by continuous wavelet transform its application is narrowed only to preliminary research phase.

## Conclusions

Both continuous and discrete wavelet transforms are the proper methods, which applied in analysing flame pulsation signals could detect the change of the fuel to be burned. However, continuous wavelet transform is only applicable at preliminary research for it requires far more computational power. Results obtained in such a way are more legible. Continuous wavelet transform could be

helpful with choosing the proper analysing wavelet to ensure the desired resolution in time and frequency (scale) domain and avoid phase distortions due to asymmetries of some wavelets.

## References

1. **Wójcik W.** Optical fibre system for flame monitoring in energetic boilers // *Technology and Applications of Lightguides: Proceedings of SPIE*. - 1997. - Vol. 3189. -P. 74–82.
2. **Wójcik W., Biegański T., Kotyra A., Smolarz A.** Forecasting of changes of flame flickering in coal flame burner // *Technology and Applications of Lightguides*. - Proceedings of SPIE. - 1997. -Vol. 3189. - P. 100–109.
3. **Chui Ch.K.** *An Introduction to Wavelets*. - San Diego: Academic Press, 1998.
4. **Białasiewicz J.T.** *Falki i aproksymacje* (in Polish). - Warszawa: WNT, 2000.

Pateikta spaudai 2003 08 27

**W. Wójcik, A. Kotyra, M. Duk, T. Golec.** *Pluoštinė-optinė sistema degančiam mazutui energetiniuose katiluose nustatyti // Elektronika ir elektrotechnika. – Kaunas: Technologija, 2003. –Nr. 7(49). – P.13–17.*

Pateikiamas mazuto nustatymo sūkurinio įpurškimo anglies degiklyje metodas. Kadangi mazuto ir anglies purkštukai yra labai arti vienas kito, tam labiausiai tinka metodas, šalinantis liepsnos pulsacijos skirtumus. Panaudota liepsnos pulsacijose esanti informacija. Verčiant atitinkamus optinius signalus į elektrinius, panaikintos bangelių transformacijos naudojant išskiriančias savybes. Il. 6, bibl. 4 (anglų kalba; santraukos lietuvių, anglų ir rusų k.).

**W. Wójcik, A. Kotyra, M. Duk, T. Golec.** *The Fibre-Optic System Detecting the Burning Mazout in Power Boilers // Electronics and Electrical Engineering. – Kaunas: Technologija, 2003. – No. 7(49). – P.13–17.*

We present a method of detection mazout inside the vortex pulverised coal burner. Since mazout and coal nozzles are placed very close, only the method utilising differences of flame pulsation seems to be the most appropriate. We used information contained within flame pulsation. After converting the appropriate optical signals into electrical form, we utilised wavelet transforms in finding the discriminating features. Il. 6, bibl. 4 (in English; summaries in Lithuanian, English, Russian).

**В.Войцик, А. Котыра, М. Дук, Т. Голец.** *Оптическая система детекции горячего мазута в энергетических котлах // Электроника и электротехника. – Каунас: Технология, 2003. –№ 7(49). – С. 13–17.*

Представлен метод детекции мазута в вихревых горелках. Так как форсунки мазута и угля находятся очень близко друг к другу, только метод, утилизирующий разницу пульсаций пламени является наиболее приемлемым. Использована информация, находящаяся в пульсациях пламени. Конвертируя оптические сигналы в электрическую форму, утилизированы волновые трансформации. Ил. 6, библи. 4 (на английском языке; рефераты на литовском, английском и русском яз.).

DOI: 10.5755/j02.eie.11105