

Full-Wave Current-Mode Precision Rectifiers Using Unity-Gain Cells

D. E. Tiliute

“Stefan cel Mare” University of Suceava
str.Universitatii nr.1, RO-720225 Suceava,Romania, dtiliute@eed.usv.ro

Introduction

Current-mode operation has proved its advantages over the conventional voltage-mode operation in a lot of application areas, not only in linear circuits as active filters [1][2] or transconductance amplifiers [3][4], but also in non-linear circuits as triggers [5], relaxation oscillators [6] or precision rectifiers [7][8]. Among these advantage we may cite the wider dynamic range, the better linearity over the full operation range, the much low temperature sensitivity and the lower power supply voltages [9]. A special class of current-mode devices, namely “unity gain cells” includes the simplest one, the voltage followers and current followers. Initially thought to be used as voltage buffers, respectively as current buffers, they have found their utility in some linear applications too [10][11].

The voltage follower (VF) is already well known from conventional voltage mode-operation. In current-mode operation the voltage follower is built in translinear technology in order to provide the benefic features enumerated above. Such realization, which is a component part of OPA660 transadmittance operational amplifier [4], is reproduced in Fig.1.

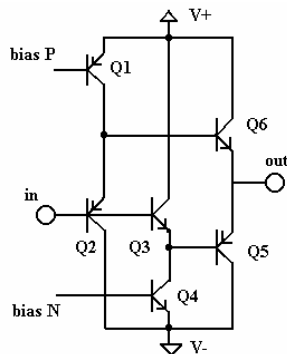

Fig. 1. A translinear implementation of a voltage follower

The bias circuits were omitted in this example. As for the symbol, in current-mode operation there are accepted two representations, depicted in Fig. 2. The notation for the input and the output are borrowed from the current conveyor that was the first current-mode device implemented [12].

The current follower (CF) is the simplest current-mode device and its symbol and equivalent circuit, with the port signals, are shown in Fig. 3.

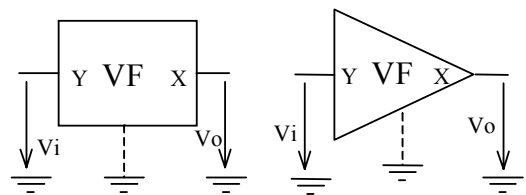

Fig. 2. Voltage follower's symbols

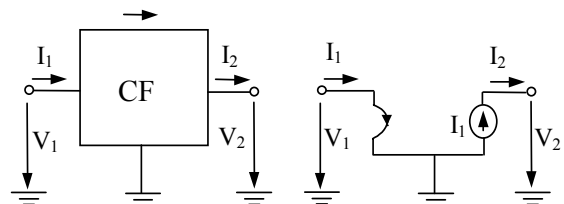

Fig. 3. Current follower' symbol and equivalent circuit

The functional equation of the CF is given in eqn.1.

$$\begin{bmatrix} V_1 \\ I_2 \end{bmatrix} = \begin{bmatrix} 0 & 0 \\ 0 & 1 \end{bmatrix} \begin{bmatrix} V_2 \\ I_1 \end{bmatrix}. \quad (1)$$

A variant of CF is the Double Output CF (DOCF) which has two outputs, the currents that flow through them having opposite signs and being both equal to the input as magnitude. The ports of DOCF are noted as follows: the input with X, the direct output with Z+ and the reversed output with Z- (opposite to the notation of current conveyor), Fig. 4. The functional equation modifies as shown in eqn.2.

$$\begin{bmatrix} V_x \\ I_{z+} \\ I_{z-} \end{bmatrix} = \begin{bmatrix} 0 & 0 & 0 \\ 1 & 0 & 0 \\ -1 & 0 & 0 \end{bmatrix} \begin{bmatrix} I_x \\ V_{z+} \\ V_{z-} \end{bmatrix}. \quad (2)$$

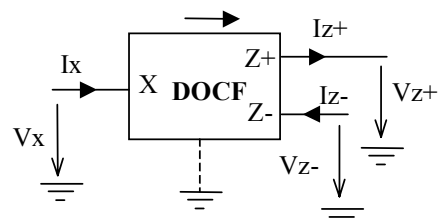

Fig. 4. DOCF symbol and port signals

In Fig. 5 we give the scheme of the DOCF, in bipolar technology, which was used to perform SPICE simulations. To increase the accuracy of DOCF, simply current mirrors were replaced with Wilson current mirrors.

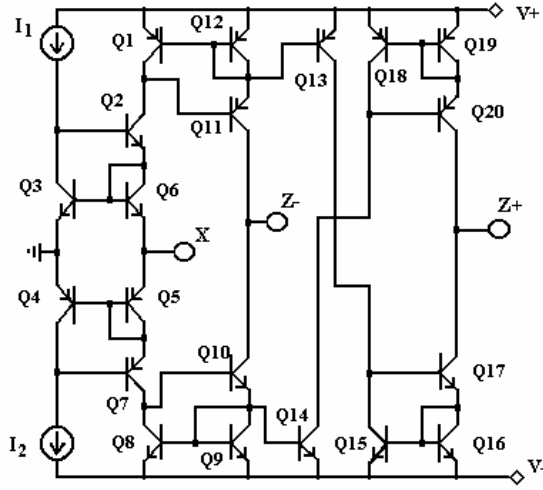

Fig. 5. DOCF scheme

Circuit description

To achieve full-wave precision rectification the first circuit we propose uses only one DOCF, four diodes and, optional, one or two resistors. The circuit schematic is presented in Fig. 6.

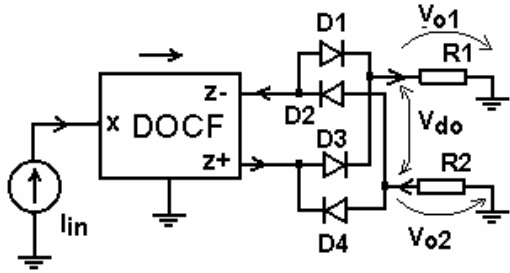

Fig. 6. First full-wave precision rectifier scheme

When the input current is positive, D1, D3 diodes are ON and D2, D4 diodes are OFF. When the polarity of the input current changes, D1, D3 diodes are OFF and D2, D4 diodes are ON. Thus, into R1 flows the positive full-wave rectified current since the negative one flows into R2. If the outputs of the rectifier must be currents, R1 and R3 are not necessary, the outputs of the diode-bridge being connected straight to the ground. When the output must be a voltage, one or both resistors are required. It is advisable that the value of the resistors be chosen as small as possible in order to improve the accuracy at high frequency due to the pole that the resistor and the output capacity of the bridge form. We must notice that it is possible to double the output voltage if consider the differential output Vdo.

In the real case, the functioning of the DOCF is described by the equation 3, where α and β are real quantities smaller than 1 but very close to it. Typical values are $\alpha=0.98$ and $\beta=0.96$.

$$\begin{bmatrix} V_x \\ I_{z+} \\ I_{z-} \end{bmatrix} = \begin{bmatrix} 0 & 0 & 0 \\ \alpha & 0 & 0 \\ -\beta & 0 & 0 \end{bmatrix} \begin{bmatrix} I_x \\ V_{z+} \\ V_{z-} \end{bmatrix}. \quad (3)$$

As a consequence, the expressions for Vo1 and Vo2 are :

$$V_{o1} = \begin{cases} I_{in} \alpha R_1 & | I_{in} \geq 0 \\ -I_{in} \beta R_1 & | I_{in} < 0 \end{cases}, \quad (4)$$

$$V_{o2} = \begin{cases} -I_{in} \alpha R_2 & | I_{in} \geq 0 \\ I_{in} \beta R_2 & | I_{in} < 0 \end{cases}. \quad (5)$$

The error of the output current on the two alternations may be computed as

$$\frac{V_{o1} | I_{in} \geq 0}{V_{o2} | I_{in} < 0} = \frac{\alpha}{\beta}, \quad (6)$$

which means an error of 2% for the values considered. This error is more than acceptable and is smaller than that provided by other circuits [8]. The differential output voltage is

$$V_{do} = V_{o1} - V_{o2} = \begin{cases} \alpha(R_1 + R_2)I_{in} & | I_{in} \geq 0 \\ -\beta(R_1 + R_2)I_{in} & | I_{in} < 0 \end{cases} \quad (7)$$

If $R_1 = R_2 = R$,

$$V_{do} = \begin{cases} 2\alpha R I_{in} & | I_{in} \geq 0 \\ -2\beta R I_{in} & | I_{in} < 0 \end{cases}. \quad (8)$$

This is the only situation when matching components are required.

If the input signal must be a voltage, a single resistor must be added to the input of the rectifier, as shown in Fig. 7.

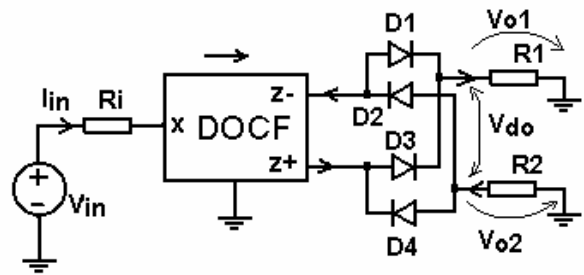

Fig. 7. Voltage input / current or voltage output current-mode precision rectifier

If the input impedance of the rectifier is critical and/or the input voltage is very small (under 100mV) this solution may be not acceptable. The third proposed circuit, depicted in Fig.8, solves this drawback by employing an additional voltage follower, which ensure the high input impedance for the rectifier.

To ensure the correct circuit functioning, the value of resistor Ri must be chosen in the range :

$$\frac{V_{vfo}^{max}}{I_{vfo}^{max}} \leq Ri \leq \frac{V_{vfo}^{max}}{I_B}, \quad (9)$$

where V_{vfo}^{MAX} represents the absolute magnitude of the output voltage of CF, I_{vfo}^{max} is the maximum current available at the CF output and I_B is the value of the bias current of the input stage in DOCF (I_1, I_2 in Fig. 5).

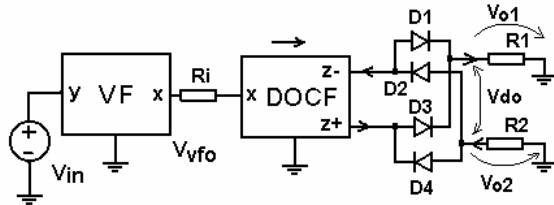

Fig. 8. High input impedance current-mode precision rectifier

Simulation results

In order to verify the circuit functioning, many SPICE simulations were performed. Some results are presented bellow. In Fig.9 we reproduce the output current through R1 for the circuit depicted in Fig. 6.

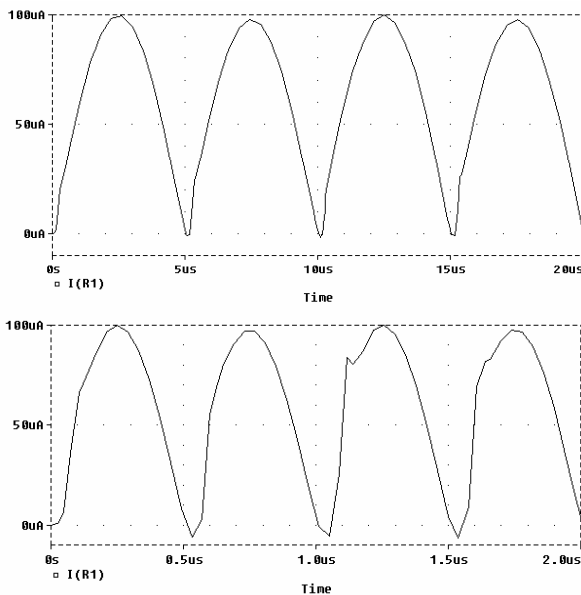

Fig. 9. The output current at 100kHz (above) and 1MHz (bellow)

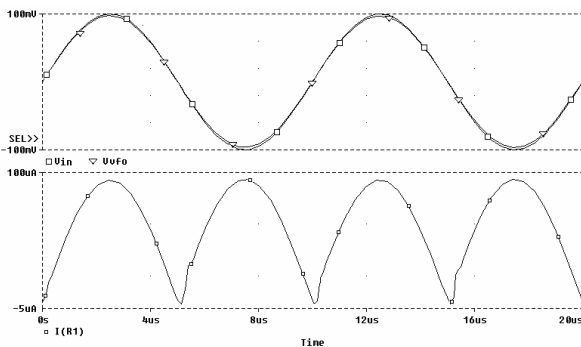

Fig. 10. The transient response of the high input impedance precision rectifier

The input current has the magnitude of 100uA and the frequency of 100kHz and of 1MHz respectively. The transient response of the high input impedance rectifier is displayed in Fig.10. On the top are displayed the input voltage (V_{in}) and the output voltage of the voltage follower (V_{vfo}) since on the bottom is displayed the current through R1.

It is clear that the response of the proposed circuits is very good, even at 1 MHz, where no operational amplifier can perform similar responses. Simulation conditions were: DOCF and VF are of the type given in Fig.5 and Fig.1; bias current of DOCF: $I_1 = I_2 = 1\text{mA}$; $R1 = R2 = 10\ \text{ohms}$; $Ri = 1\text{Kohm}$; D1...D4 of BA482 type. Voltage supply: $\pm 10\text{V}$.

Conclusions

The current-mode precision rectifiers presented are very simple, they use as active devices only unity gain cells. Due to the reduced number of external passive components they are suitable for integration. The accuracy ensured is very good even at high frequency. Also, with only one exception, the circuits don't need any component matching. Furthermore, the circuits provide outputs signals as currents or voltages as well.

References

1. Roberts G. W., Sedra A. S. All Current Mode Frequency Selective Circuits // Electronics Letters. - 8th June 1989. - Vol. 25, No.12. - P. 759-761.
2. Lidgley F. G. Universal Active Filter Using Current Conveyors // Electronics Letters. - 5th June 1986. - Vol.22, No.16. - P. 662-663.
3. Di Cataldo G., Palumbo G., Penissi S. A Schmitt Trigger By Means of CCII+ // Int. Journal of Circuit Theory and Applications. - 1995. -Vol.23. - P. 161-165
4. Cicekoglu M. O., Kuntman H. On the design of CCII+ based relaxation oscillator employing single grounded passive element for linear period control // Microelectronics Journal 29 (1999). - Elsevier Ltd. - P. 993-999.
5. Toumazou C., Lidgley F. J., Chattong S. High frequency current conveyor precision full-wave rectifier // Electronics Letters. - 1994. - No.10, Vol. 30. - P. 745-746.
6. Tiliute D. E. On the current-mode rectification // Annals of the "Stefan cel Mare" University of Suceava, Romania, Electrical Section. - No.11, 1999. - P. 61-65.
7. Tomazou C., Lidgley F. G., Haigh D. Analog IC Design: the current mode approach. Exeter, UK, Peter Pelegrinus, 1990.
8. Okine M., Katsuhara N. Current-Mode Active RC Filters Using Current Followers // IEICE Trans. Fundamentals. - Vol. E81-A, No.2. - February 1998.
9. Tiliute D. E. Low Input Impedance Current-Mode Active Filter Using Current Follower // SCS 2003, July 10-11. - Iasi, Romania, Proc. - Vol.2 - P. 577-579.
10. Smith K. C., Sedra A. The current conveyor: a new circuit building block // Proc. IEEE. - Vol. 56, Aug. 1968. - P.1368-1369.

D. E. Tiliute. Pilnabangis srovės tikslumo lygintuvas, naudojantis vienkartinio stiprinimo elementus // Elektronika ir elektrotechnika. - Kaunas: Technologija, 2003.- Nr. 7(49). – P. 26 -29.

Pateikiamas naujas srovės tikslumo lygintuvas, kaip aktyvius elementus naudojantis srovės kartotuvus. Aptariami trys grandyno variantai, turintys „srovės“ modulį. Pirmajame grandyne įėjimo signalas sukuriama srovės šaltinių, o kituose įėjimo signalai yra įtampos. Visų grandynų išėjimo signalai yra ir įtampų, ir srovių. Naudojant „srovės“ modulius, grandynai turi labai gerą pereinamąjį atsaką, todėl tinka aukštojo dažnio įtaisams. Pateikiami SPICE modeliavimo rezultatai. Il.9, bibl.10 (anglų kalba; santraukos lietuvių, anglų ir rusų k.).

D. E. Tiliute. Full-Wave Current-Mode Precision Rectifiers Using Unity-Gain Cells // Electronics and Electrical Engineering.- Kaunas: Technologija, 2003. – No. 7(49). – P. 26-29.

This paper presents a new precision full-wave rectifier, which uses current followers as active devices. Three variants of the circuit are discussed, all being current-mode. In the first circuit the input signal is delivered by a current sources while in the next two circuits the input signals are voltages. All circuits provide outputs signals both as voltages and as currents. Due to the current-mode operation the circuits have a very good transient response that make them suitable for high frequency applications. SPICE simulations and conclusions are included. Ill 9, bibl. 10 (in English; summaries in Lithuanian, English, Russian).

Д. Е. Тилиуте. Выпрямитель точности с двойным чередованием в рабочий модуль «в сети» с клетками с единым усилением // Электроника и электротехника. - Каунас: Технология.- 2003.- № 7(49). – С. 26-29.

В настоящей работе представлен новый выпрямитель точности с двойным чередованием, который использует в качестве активных установок токоповторители. Для обсуждения представлены три варианта электрической цепи – все имеющие рабочий модуль «в сети». В первой цепи входящий сигнал произведен источником тока, в то время как в остальных двух цепях входящий сигнал генерирован источником напряжения. Все цепи производят выходной сигнал как в виде тока, так и в виде напряжения. Благодаря режиму работы «в сети» цепи представляют очень хороший переходной ответ и это делает его подходящим для высокочастотных приложений. В работу включены также результаты симуляций SPICE и выводы. Ил. 9, библи. 10е (на английском языке; рефераты на литовском, английском и русском яз.).

