

## Computer Modeling of the Dynamic Processes for Stepping Motor

**B. Karaliūnas**

*Department of Automation, Vilnius Gediminas Technical University,  
Naugarduko str.41, LT-03227 Vilnius, Lithuania, phone: +370 274 50 63, e-mail: Bronius.karaliunas@el.vgtu.lt*

### Introduction

To be able to restructure our country economy under the principal of free market as well as to integrate it into the transatlantic and European structures, it is necessary to introduce and assimilate new devices and machinery for automated production, computerized integrated IT systems. New technologies require electric drives applied in the modes of starting, operating, processing, speed or torque adjustment and stabilization, accurate braking, positioning and other modes. To work out the mentioned above devices there are widely used not only rotational asynchronous and DC motors, but stepping motors as well the operation of which is based on the impulsive magnetic field. Such type of motors are applied in space and radiolocation systems, in the automobile and laser industries, video cameras, telescopes, control of spaceship aerial wires and other systems. They are widely applied for military industry, robots technology, flexible production systems [1].

Stepping motors are very successfully used for the systems, where the instructions are submitted in the digital and impulse form. That is why in the control systems of the stepping motors there are links which accept, process and transmit digital signals. In the systems of automated manufacturing and control, there has been achieved greater accuracy of digital control, higher savings, quick – action and quality after the principals of digital control were applied and when processing discrete signals of controlled sensors.

In modern technologies and latest mechatronic systems there are very widely used variable reluctance stepping motors, permanent-magnet stepping motors and hybrid stepping motors [2]. If considering their control system, then these motors are able to operate in the modes of full step, half step and micro stepping.

The static characteristics of stepping motors and their drives are considerably widely analyzed in the literature [3, 4]. There is presented the theory that the torque of the motor is capable of developing is mostly dependant on the voltage of the supply power, frequency of impulses as well as on the torque and character of the load. However, the dynamic qualities of stepping motors in various modes of operation haven't been precisely analyzed yet.

The objective of the work is to compile the digital model of the dynamic processes of the stepping motor and obtain the results of the imitation of dynamic characteristics.

### Differential Equations and Block Diagram

In order to receive differential equations of the dynamic processes of the stepping motor and to compile its block diagram, it is necessary to analyze the second type Lagrange (J. L. Lagrange, 1736 – 1813) differential equation. It describes the movement of a drive and relates various sorts of acting energy present in the drive:

$$\frac{d}{dt} \left( \frac{\partial W_k}{\partial \omega_i} \right) - \frac{\partial W_k}{\partial \varphi_i} + \frac{\partial W_p}{\partial \varphi_i} + \frac{\partial W_d}{\partial \varphi_i} = T_i, \quad (1)$$

where  $W_k$  is kinetic energy;  $W_p$  is potential energy;  $W_d$  is dissipation of energy;  $\omega_i$  and  $\varphi_i$  are angular speed and shift of  $i$  link;  $T_i$  is a generalized torque;  $i = 1, 2, \dots, n$ .

For the electric drive the number of equations most often are compiled taking into consideration the number of degrees of freedom it possesses.

Further we are going to analyze a two – phase variable reluctance stepping motor the both windings and the magnetic core of which are symmetrical, the electromagnetic parameters of the windings are equal, magnetic permeability is extremely high and the air gap is identical. The linkage fluxes of the phases  $a$  and  $b$  of such a motor are the functions of the currents  $i_a, i_b$ , the number of a rotor teeth  $z$  and the turning angle  $\theta_r$  of the rotor [3]:

$$\begin{cases} \psi_a = i_a L_s + \psi_m \cos(z\theta_r), \\ \psi_b = i_b L_s + \psi_m \sin(z\theta_r), \end{cases} \quad (2)$$

where  $L_s$  – is the inductance of the stator windings;  $\psi_m$  – is the maximum value of the flux.

The electromagnetic torque of the motor is derived as partial derivative of the magnetic energy according to the turning angle of the rotor:

$$T_{em} = \frac{\partial W_m}{\partial \theta_r} . \quad (3)$$

When the stepping motor is in operation, the magnetic energy accumulated in it is calculated in the following way:

$$W_m = \frac{1}{2}(L_s i_a^2 + L_s i_b^2) + \psi_m i_a \sin(z\theta_r) + \psi_m i_b \cos(z\theta_r) + W_d . \quad (4)$$

According to the equations (1) – (4) it is possible to write the following system of differential equations [3]:

$$\begin{cases} J_r \frac{d^2 \theta_r}{dt^2} = T_{em} - B_m \omega_r - T_l , \\ \frac{d\omega_r}{dt} = \frac{z\psi_m}{2J_r} [i_b \sin(z\theta_r) - i_a \cos(z\theta_r)] - \frac{1}{J_r} (B_m \omega_r + T_l) , \\ \frac{d\theta_r}{dt} = \omega_r , \end{cases} \quad (5)$$

where  $J_r$  – is the torque of inertia of the rotor;  $B_m$  – is the coefficient of attenuation or viscous friction;  $\omega_r$  – is the angular speed of the rotor;  $T_l$  – is the torque of the motor load.

Differential equations characterize the change of currents in the windings of the stator which were derived from the equations of voltage balance:

$$\begin{cases} \frac{di_a}{dt} = \frac{u_a}{L_s} + \frac{z\psi_m}{L_s} \omega_r \cos(z\theta_r) - \frac{i_a}{T_{elm}} , \\ \frac{di_b}{dt} = \frac{u_b}{L_s} + \frac{z\psi_m}{L_s} \omega_r \sin(z\theta_r) - \frac{i_b}{T_{elm}} , \end{cases} \quad (6)$$

where  $T_{elm} = \frac{L_s}{r_s}$  – is the electromagnetic time constant of the motor;  $u_a$  and  $u_b$  – is the voltages of the stator windings.

The equations (4) – (6) describe the dynamic processes of the variable reluctance stepping motor and enable the research to be carried on the currents of the stator, angular speed of the rotor, the turning angle of the rotor and reaction of the torque when the motor supplies one control impulse. In this case the rotor tends to be turned by one step. The equation of the rotor movement when the motor is supplied with a series of control impulses is possible to be obtained by summing up the appropriate equations of one step. It means that the final conditions of the previous step fully correspond to the initial conditions of the following (new) step.

The rotor which is not under load of the stepping motor tend to oscillate by its own frequency of free oscillations on the status of its stable operation:

$$\omega_0 = \sqrt{\frac{pT_{max}}{J_r}} , \quad (7)$$

where  $T_{max}$  is the amplitude of the static pull – in torque of the structure;  $p$  – is the number of pairs of poles of the stator.

This value is important to be known when determining the frequency of control impulses  $f_{rez}$ . When the stepping motor is in this mode it loses no load pull – out moment and steps.

The model of the dynamic processes of the motor and its block diagram are compiled according to the equations (4) – (6). The software of Matlab/Simulink is applied here which has integrated the methods of the solution of differential equations for the motor. The block diagram of the digital model of the stepping motor is presented in Fig. 1.

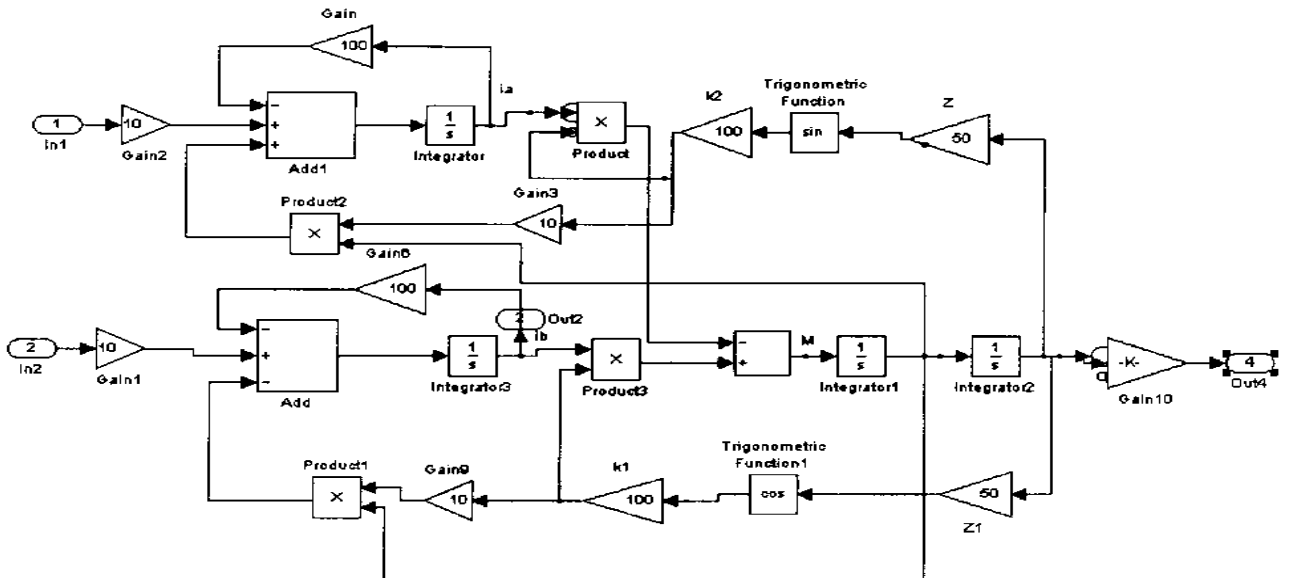

Fig. 1. Block diagram of the model of dynamic processes for stepper motor

## Results of simulation

To analyze dynamic processes there were introduced for the model the following parameters: magnetic flux  $\psi_m = 0,2 [Wb]$ ; resistance of the stator winding  $r_s = 2,2 [\Omega]$ ; inductance of the windings  $L_s = 0,01 [H]$ ; inertia torque of the rotor  $J_r = 0,1 [kgm^2]$ ; the number of the teeth of the rotor  $z = 50$ .

At first there were investigated the dynamic processes of the stepping motor when the motor was supplied with one control impulse. The transitional processes of the currents at the moment of starting are presented in Fig. 2. In Fig. 3 there is presented the change of the turning angle, but in Fig. 4 there is presented the transitional process of the speed of the stepping motor. The transitional process of the electromagnetic torque at the moment of starting the no-load motor is presented in Fig. 5.

The submitted digital model of the motor enables to receive the results of the dynamic processes and allows the imitation of the characteristics by changing the parameters of the motor, the number of the teeth of the rotor and electromagnetic as well as inertia time constants.

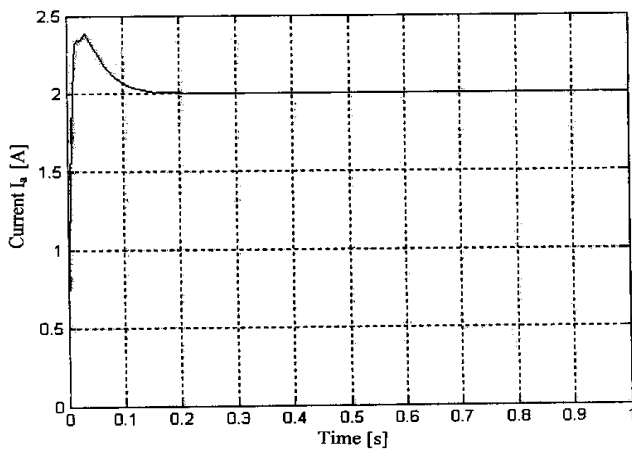

a)

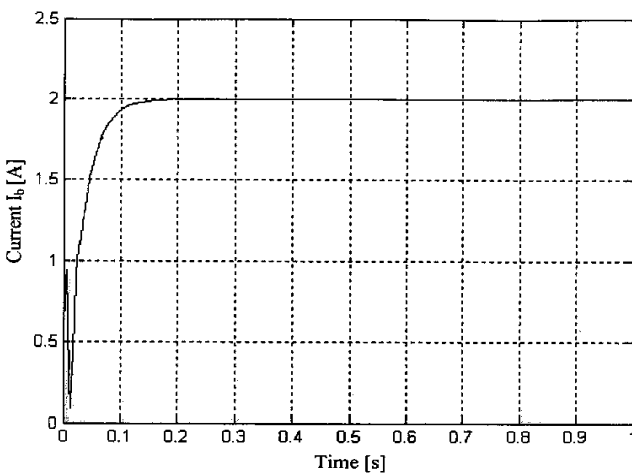

b)

**Fig. 2.** Transient processes of the stator currents: a) – variation of the current  $I_a$ ; b) – variation of the current  $I_b$

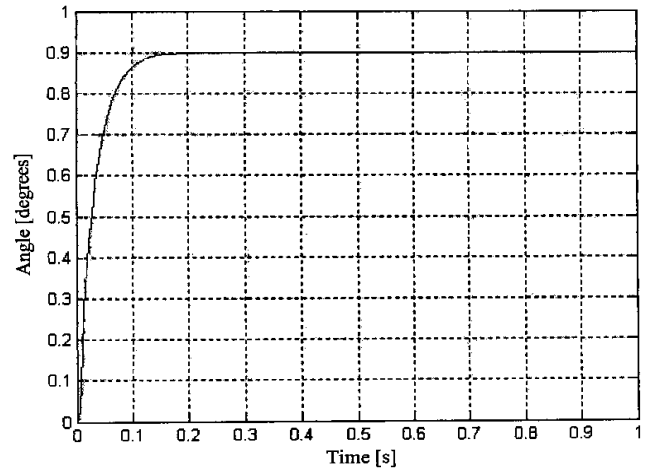

**Fig. 3.** Variation law of the turn angle of rotor

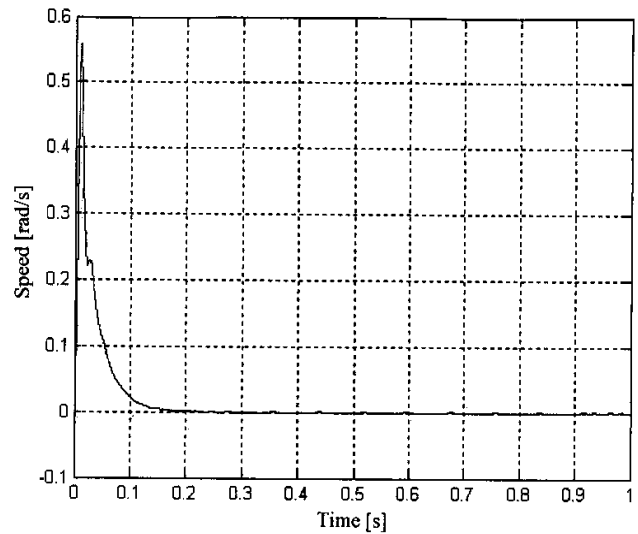

**Fig. 4.** Transitional process of the rotor angular speed

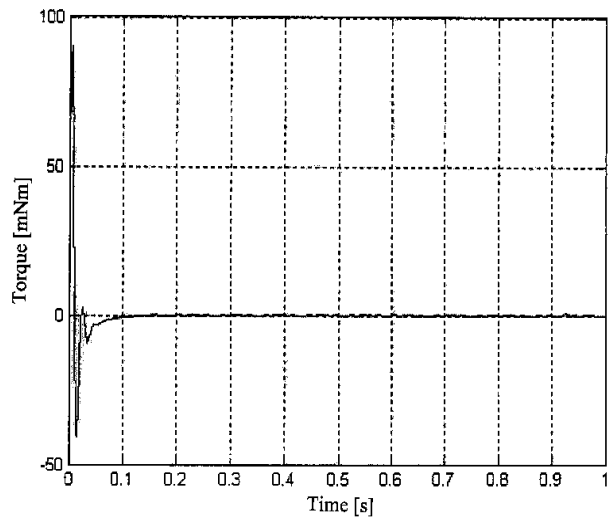

**Fig. 5.** Transitional process of electromagnetic torque with the direct starting of no-load motor

The received results could be applied in compiling the optimal systems of control of the stepping motors.

The results of modeling indicate that when switching the windings of the stator from one control impulse to another the currents in the windings increase suddenly then decrease abruptly. Due to that the axis of the magnetic field of the stator turns diacritically but the motion of the rotor is described by the static load angle characteristic  $T_{elm} = f(\theta_r)$ . That is the main characteristic of the motor according to which the other dependencies are calculated and evaluated the working capacity of the quality of the motor. The form of the angle characteristics of the stepping motor could be various. If the peaks increase and decrease of the torque in the characteristic are registered there may be that during the process of operation the rotor is going to lose the synchronism.

The received results of imitation indicate that at the very beginning of the step the processes of oscillation of the rotor speed and electromagnetic torque are operating and they are predetermined by the changes of the energy functioning between the motor and control system.

### Conclusions

1. The new model of the dynamic processes of the variable reluctance stepping motor was compiled in the modern Matlab/Simulink system, which is rather widely applied in the scientific and engineering practice.

2. The compiled model singles out by the versatility as by applying it, is could be implemented to model the

transitional processes and dynamic characteristics of the motor when only one control impulse is supplied into the stator windings or when the sets of a certain frequency of the control impulses are supplied into them.

3. During the process of modeling which are used in rather wide boundaries there could be changed the parameters of motors, its load, frequency of control impulses, electromagnetic and inertial time constants as well as the number of the teeth of the rotor.

4. The results of modeling indicate that for the processes of motor starting are specific for rather strong currents, speed of the rotor and oscillations of the electromagnetic torque at the beginning of starting and for the exponential reduction at the end.

### References

1. **Kollmorgen** product catalog. Step motors and controls. – Northampton: Arturs VMG. – 73 p.
2. **Stolting H. D., Beisse A.** Elektrische Kleinmaschinen. – Stuttgart: B. G. Teubner Verlag, 1987. – 227 p.
3. **Kenio T., Sugawara A.** Stepping motors and their microprocessor controls. – 2 Ed. Oxford: Oxford University Press, 1995. – 200 p.
4. **Khorrami F., Krishnamurthy P., Melkote H.** Modeling and adaptive nonlinear control of electric motors. – Berlin: Springer, 2003. – 523 p.

Submitted for publication 2007 12 14

### **B. Karaliūnas. Computer Modeling of the Dynamic Processes for Stepping Motor // Electronics and Electrical Engineering. – Kaunas: Technologija, 2008. – No. 3(83). – P. 81–84.**

The issues concerning the dynamic processes of the digital modeling for variable reluctance stepping motor were investigated. The differential equations for two – phase motor are presented on the bases of which the model of the stepping motor was compiled as well as the block diagram of it was obtained. The differential equations characterize the change of the currents in the windings of the analyzed motor and are derived from the equations of the voltages balance. The model of the dynamic processes was compiled in the modern system of Matlab/Simulink system. The submitted model is available for the research of the transitional processes and dynamic characteristics of the stepping motor, when only one control impulse is supplied into the windings of the stator or when a certain series of control impulses are supplied into. The obtained results indicate that at the very beginning of the step there are processes of the stator currents, speed of the rotor, oscillation processes of the electromagnetic torque, which are determined by the energy changes between the motor and control system. Ill. 5, bibl. 4 (in English; summaries in English, Russian and Lithuanian).

### **В. Каралюнас. Компьютерное моделирование динамических процессов шагового двигателя // Электроника и электротехника. – Каунас: Технология, 2008. – № 3(83). – С. 81–84.**

Рассматриваются вопросы компьютерного моделирования динамических процессов реактивного шагового двигателя. Представлены дифференциальные уравнения двухфазного реактивного двигателя, по которым создана компьютерная модель и получена его структурная схема. Изменение тока в обмотках статора описывают дифференциальные уравнения, полученные на основании уравнений баланса напряжений. Модель динамических процессов составлена в системе Matlab/Simulink. Представленная модель пригодна для исследования переходных процессов и динамических характеристик как при подаче на обмотки статора одного управляющего импульса, так и при подаче на них серии импульсов соответствующей частоты. Результаты моделирования показывают, что в начале переходного процесса возникают затухающие колебания токов, скорости и момента двигателя. Ил. 5, библи. 4 (на английском языке; рефераты на английском, русском и литовском яз.).

### **B. Karaliūnas. Žingsninio variklio dinaminių procesų kompiuterinis modeliavimas // Elektronika ir elektrotechnika. – Kaunas: Technologija, 2008. – Nr. 3(83). – P. 81–84.**

Nagrinėjami reaktyviojo žingsninio variklio dinaminių procesų kompiuterinio modeliavimo klausimai. Pateiktos dvifazio reaktyviojo variklio diferencialinės lygtys, pagal kurias sudarytas kompiuterinis modelis ir gauta jo struktūrinė schema. Srovių kitimą statoriaus apvijose apibūdina diferencialinės lygtys, gautos iš įtampų balanso lygčių. Dinaminių procesų modelis sudarytas modernioje Matlab/Simulink sistemoje. Pateiktas modelis tinka žingsninio variklio pereinamiesiems procesams ir dinaminėms charakteristikoms tirti, kai į statoriaus apviją perduodamas tik vienas valdymo impulsas, arba kai į jas siunčiama tam tikro dažnio valdymo impulsų seka. Gauti modeliavimo rezultatai rodo, kad pačioje žingsnio pradžioje vyksta statoriaus srovių, rotoriaus greičio, elektromagnetinio momento švytuojamieji procesai, kuriuos sąlygoja energijos mainai tarp variklio ir valdymo sistemos. Il. 5, bibl. 4 (anglų kalba; santraukos anglų, rusų ir lietuvių k.).

