

## Simulation of Transient Processes in the Fast Track-and-Hold Circuits

**V. Jasonis, A. J. Marcinkevičius**

*Vilnius Gediminas Technical University, Computer engineering department, Naugarduko str. 41-437, LT-03227 Vilnius, Lithuania, phone: +370 5 2744772, e-mail: Vaidas.Jasonis@el.vgtu.lt; Albinas.Marcinkevicius@el.vgtu.lt*

### Introduction

The track-and-hold circuits (THC) operate in the fast integrated analog-digital converters (ADC) as well as in the conveyer-like high precision sigma-delta modulators. The analysis in megahertz frequency range of such circuits is presented in the references [1-2].

The THC dynamic errors in the signal tracking mode for sinusoidal signal in a gigahertz frequency range were analyzed and the output signal time diagrams depending on the circuit internal and topological parasitic electrical parameters were presented in this paper. The experience gained in the earlier analysis of sample-and-hold circuits [3-5] was used in this work. The influence of the signal transfer lines with distributed parameters on the THC precision, which is an urgent problem, was evaluated in this paper [6-7].

The results of the simulation and the families of the curves allow more optimal choosing of the THC characteristics depending on the needed signal processing frequency and the THC precision.

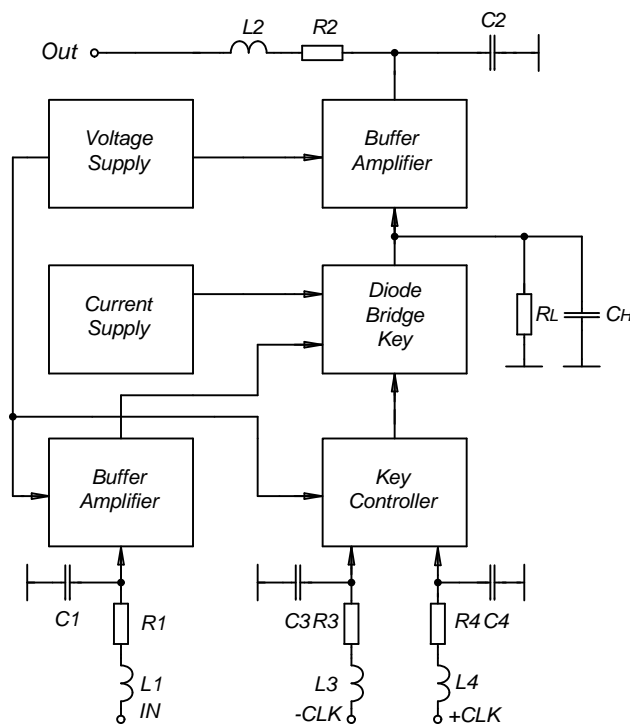
### The simulation of the track-and-hold circuit with P-Spice

The THC was simulated with P-Spice using models of the 0.5  $\mu\text{m}$  integrated bipolar transistors technology. The THC was simulated in the cases when ADC precision was 8 and 10 bits, with the parasitic inductances of 0.2 nH and 0.05 nH, and the clock frequency – 5 GHz. The parasitic inductances correspond to the connection wires between THC and the outside circuits, approximately 200  $\mu\text{m}$  and 50  $\mu\text{m}$  in length. When designing the 8-bit THC, one least significant bit (LSB) was 6.25 mV, and when designing the 10-bit THC, 1 LSB = 1.56 mV. The analog input signal dynamic range was 1.6 V, when the supply voltage was 3.3 V.

It is convenient to estimate the THC error, represented by LSBs, in the middle point of the track mode. In the hold mode, the errors appear when the voltage of the holding capacitor is dropping. It is convenient to estimate such errors at the middle point of the hold mode. When measuring, the errors were estimated in both track and hold modes, but for simplicity, only the major error was taken

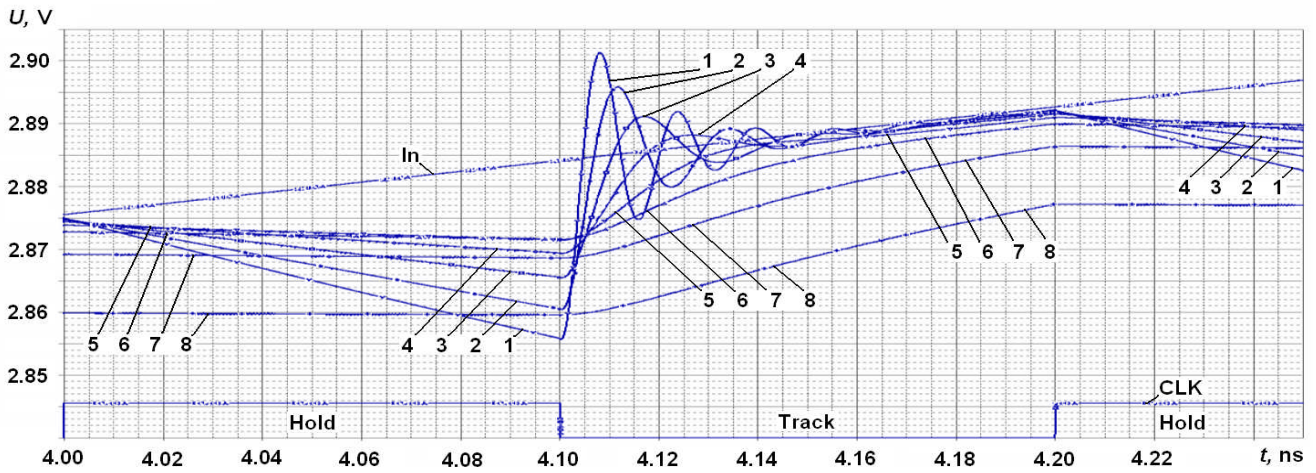
into account, which allowed us to get more reliable results than those presented in [3].

The open-loop circuit with the diode bridge key was chosen for simulation and it is presented in Fig. 1.

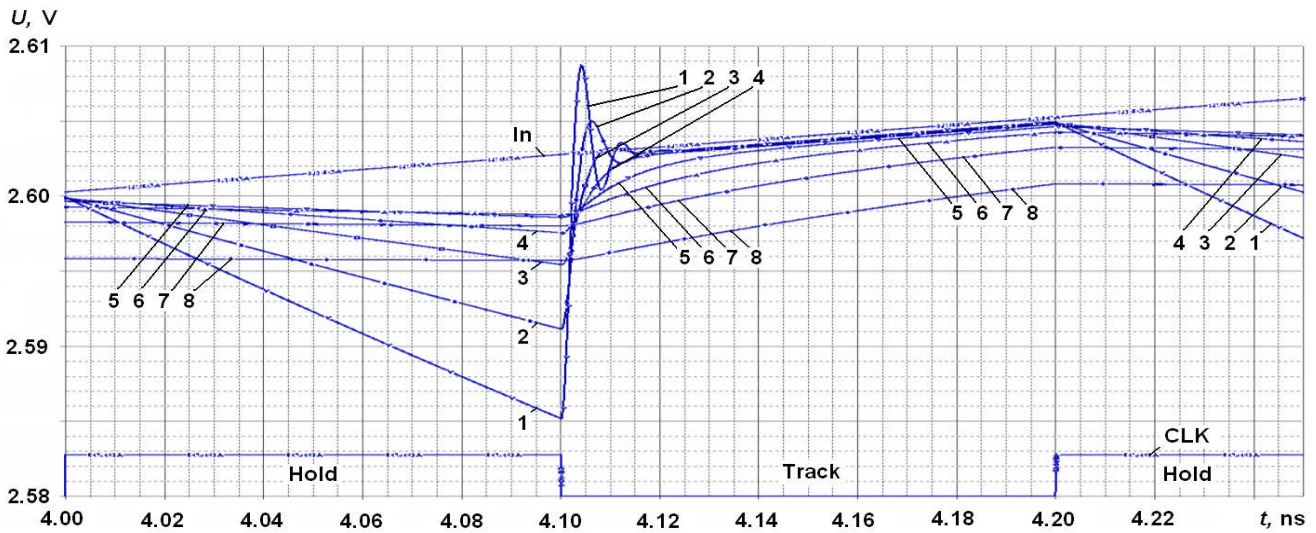


**Fig. 1.** Simplified track-and-hold circuit

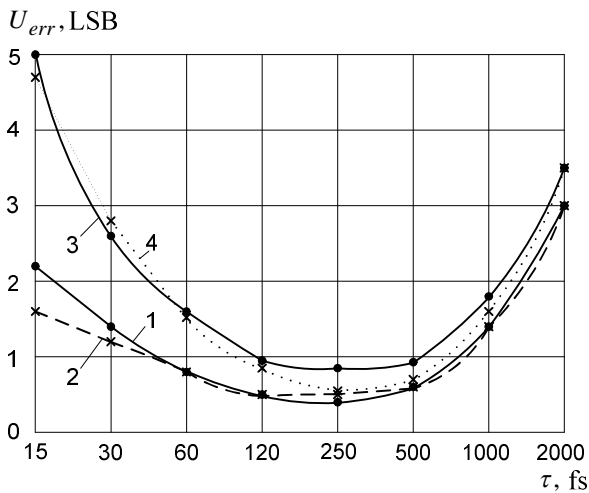
The simulation was performed for 4 cases – when the ADC precision was 8 and 10 bit, and in each case  $L = 0.05$  nH and  $L = 0.2$  nH. Two of four cases are presented in Figs. 1-2 because of the lack of place. The clock signal with the decreased amplitude and shifted on the voltage axis for better representation is presented in Figs. 1-2. The hold time constant  $\tau$  was calculated by multiplying the holding capacitance  $C_H$  by the fixed load resistance  $R_L = 1$  M $\Omega$ . The THC errors were calculated, translated to LSB units and they are presented in Fig. 4.



**Fig. 2.** 8-bit THC time diagrams, when parasitic inductances  $L = 0.2$  nH. Here CLK – 5 GHz clock signal, In – analog input signal, 1 – THC output signal, when  $\tau = 15$  fs, 2 –  $\tau = 30$  fs, 3 –  $\tau = 60$  fs, 4 –  $\tau = 120$  fs, 5 –  $\tau = 250$  fs, 6 –  $\tau = 0.5$  ps, 7 –  $\tau = 1$  ps, 8 –  $\tau = 2$  ps



**Fig. 3.** 10-bit THC time diagrams, when parasitic inductances  $L = 0.05$  nH. Here CLK – 5 GHz clock signal, In – analog input signal, 1 – THC output signal, when  $\tau = 15$  fs, 2 –  $\tau = 30$  fs, 3 –  $\tau = 60$  fs, 4 –  $\tau = 120$  fs, 5 –  $\tau = 250$  fs, 6 –  $\tau = 0.5$  ps, 7 –  $\tau = 1$  ps, 8 –  $\tau = 2$  ps



**Fig. 4.** Dependences of THC errors on  $\tau$ . Here curve 1 – 8 bit ADC and  $L = 0.05$  nH, 2 – 8 bit ADC and  $L = 0.2$  nH, 3 – 10 bit ADC and  $L = 0.05$  nH, 4 – 10 bit ADC and  $L = 0.2$  nH

We see in Fig. 4 that when the THC clock speed is 5 GHz, the minimal THC error is with  $\tau = (120-500)$  fs. In this case, we have the THC precision of about 0.5 LSB for the 8-bit ADC and about 0.75 LSB for the 10-bit ADC. When  $L$  increased from 0.05 nH to 0.2 nH, the THC precision decreased slightly. When  $L = 0.2$  nH, the transient processes in the signal hold mode (Fig. 2) lasted 45 % of the whole hold time, and when  $L = 0.05$  nH (Fig. 3), the transient processes lasted only 15 % of the whole hold time. It demonstrates that it is important to choose such an ADC clock signal that comparators could measure the input signal at the correct time moment for better precision.

By decreasing the THC clock speed or the number of ADC bits, THC errors decrease even more. Another way for improving the THC precision is to choose another circuit, for example, with the closed-loop structure. New or improved circuitry decisions are constantly proposed in the

new scientific literature [1-2], which allows creating simple, precise and fast THCs.

When analyzing the THC errors, it is important to evaluate what part of the error the THC contributes to the whole ADC error, but to solve this problem more investigations need to be performed.

### Calculation of the relative dynamic error in the signal track mode

The total relative dynamic error in the analog input signal tracking mode in the Gauss signal case can be calculated as [3]:

$$\delta_{dG} = \frac{\sqrt{\exp\left(-2\frac{\tau_T - \tau_R}{\tau_e}\right) \cdot [1 - F(U_0)] \times \left(2\tau_e \Delta F_G\right)^2 + \frac{U_0^2}{\sigma_x^2} \left[\frac{\tau_T - \tau_{RG}}{\tau_e}\right]^2}}{\times} \quad (1)$$

For the sinusoidal signal, expression (1) becomes simplified:

$$\delta_d = \sqrt{\exp\left(-2\frac{\tau_T - \tau_R}{\tau_E}\right) \times \left[1 - \frac{2}{\pi} \arcsin\left(\frac{2U_0}{U_m \omega_s \tau_H}\right)\right] \cdot \frac{2U_0^2}{U_m^2} \left[\frac{\tau_T - \tau_R}{\tau_E}\right]^2 + (2\tau_E \omega_s)^2} \quad (2)$$

Here  $\tau_R$  is the amplifier recharge time constant for the sinusoidal signal, which can be calculated by equation:

$$\tau_R = \tau_E \left[ \frac{2U_m}{\pi U_0} \omega_s \tau_H - 1 \right] \quad (3)$$

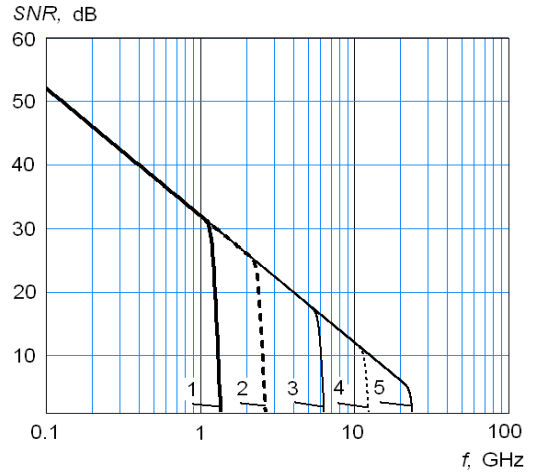
The THC parameters can be presented as the signal / noise and distortion ratio by equation:

$$SNR = 10 \log(\delta_d^{-2}) \quad (4)$$

Here  $\tau_e$  is the equivalent time constant,  $\Delta F_G$  is the Gaussian form signal average square deflection of the frequency range,  $\pm U_0$  is the linear part of the amplifier transfer characteristic,  $\sigma_x$  is the analog signal level average square deflection,  $\tau_T$  is the analog input signal track time,  $\tau_H$  is the analog input signal hold time,  $\tau_{RG}$  is the average recharge time,  $F(U_0)$  is the integrated probability distribution function,  $SNR$  is the signal/noise and distortion ratio.

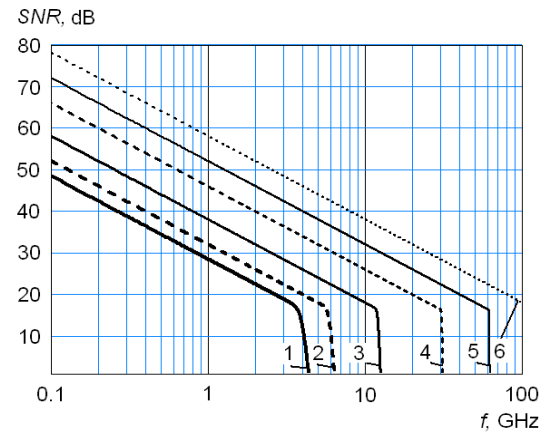
The dependences of the THC dynamic errors on the analog input signal frequency, the equivalent hold time constant and the amplifier transfer characteristic linear part were calculated using software MathCAD. The obtained characteristics are presented in Figs. 5-6. The dependences of the THC dynamic error in the signal tracking mode on  $f$

are presented in Fig. 5, when  $\tau_E = 2$  ps,  $U_m = 1$  V,  $\tau_T = \tau_H = 50$  ps.



**Fig. 5.** Dependences of the THC dynamic error in the tracking mode on  $f$  when  $U_0=0.01$  V (curve 1);  $U_0=0.02$  V (2);  $U_0=0.05$  V (3);  $U_0=0.1$  V (4);  $U_0=0.2$  V (5)

The dependences of THC dynamic error on  $f$  are presented in Fig. 6, when  $U_0=0.05$  V, and  $\tau_E$  is different.



**Fig. 6.** Dependences of the THC dynamic error in the track mode on  $f$  when  $\tau_E = 3$  ps (curve 1);  $\tau_E = 2$  ps (2);  $\tau_E = 1$  ps (3);  $\tau_E = 0.4$  ps (4);  $\tau_E = 0.2$  ps (5);  $\tau_E = 0.1$  ps (6)

We see in Figs. 5-6 that when the analog input signal frequency increases, the THC precision decreases. For example, when the linear part length of the amplifiers transfer characteristic is  $U_0=0.05$  V, in order to have the analog input signal frequency of 1 GHz with 50 dB  $SNR$ ,  $\tau_E = 0.2$  ps needs to be chosen, and under the same conditions when the frequency increases to 5 GHz,  $SNR$  decreases to 38 dB. The following characteristics allow us to practically choose the THC parameters for the needed frequency and precision.

### Conclusions

The track-and-hold circuit with the clock speed of  $5 \cdot 10^9$  samples per second was simulated in this work. The parasitic parameters of the connection lines between the THC and external circuits were evaluated. The equations

for the relative dynamic THC error calculation in the signal track mode for the Gaussian signal were derived.

The optimal hold time constant for the 5 GHz clock signal is (120-500) fs. In such a case, the THC precision is about 0.5 LSB for the 8-bit ADC and about 0.75 LSB for the 10-bit ADC. When parasitic inductances increased from 0.05 nH to 0.2 nH, the THC precision decreased slightly, but transient processes in the signal hold mode lasted 3 times longer.

In order to obtain the needed THC operation frequency and precision, the parameters of the THC, such as the amplifier transfer characteristic linear part length and the equivalent signal holding time constant need to be chosen.

## References

1. **Seon J. K., Nam K. H., Kang S. H., et al.** A simple and accurate track-and-hold circuit using operational transconductance amplifier // Proceedings of the 14th International Conference on Mixed Design of Integrated Circuits and Systems, MIXDES'07. – Ciechocinek, Poland, 2007. – P. 215–218.
2. **Yoshizawa H., Temes G. C.** Switched-Capacitor Track-and-Hold Amplifiers With Low Sensitivity to Op-Amp Imperfections

// IEEE Transactions on Circuits and Systems I: Regular Papers, 2007. – Vol. 54. – P. 193–199.

3. **Marcinkevičius A. J., Jasonis V.** Investigation of the Overvoltages in the Fast Track-and-Hold circuits // Proceedings of the XVII International Conference on Electromagnetic Disturbances EMD'2007. – Bialystok. – 2007. – Vol. 2. – P. 121–124.
4. **Marcinkevičius A. J., Jasonis V.** Calculation of Dynamic Characteristics of the Memory Circuit for Analog-to-Digital Information Converters // Proceedings of the XIV International Conference on Electromagnetic Disturbances EMD'2004. – Vilnius, 2004. – P. 211–214.
5. **Marcinkevičius A. J., Jasonis V.** The Calculation of Dynamic Errors in Signal Transformation Circuits of Analog-to-Digital Converters for Mechatronic Systems // Solid State Phenomena. – 2006. – Vol. 113. – P. 131–136.
6. **Staras S., Daskevicius V., Skudutis J.** Simulation and Properties of the Quasi-Symmetrical Helical Structure // IEEE Transactions on Electron Devices. – 2006. – Vol. 53, No 10. – P. 2649–2654.
7. **Navickas R., Barzdėnas V.** The hybrid pixel sensors and read-out electronics // Solid State Phenomena. – 2006. – Vol. 113. – P. 453–458.

Submitted for publication 2008 01 08

## **V. Jasonis, A. J. Marcinkevičius. Simulation of Transient Processes in the Fast Track-and-Hold Circuits // Electronics and Electrical Engineering. – Kaunas: Technologija, 2008. – No. 3(83). – P. 59–62.**

The dynamic errors of the track-and-hold circuit (THC) in the signal track mode for the sinusoidal signal were analyzed. The output signal time diagrams, which depend on the parasitic electrical parameters of the internal and external circuit, were presented. The results of the modeling, when the THC is intended for the 8 and 10-bit ADC with two different sets of the parasitic electrical parameters of the THC, were presented. It has been determined that the best hold time constant is 120-500 fs for the THC clock speed of 5 GHz. In such a case, the precision of the THC is about 0.5 of the least significant bit (LSB) for the 8-bit ADC and about 0.75 LSB for the 10-bit ADC. When the values of the parasitic inductances increased from 0.05 nH to 0.2 nH, the THC precision decreased slightly. When the linear part length of the amplifier transfer characteristic is 0.05 V, in order to obtain the analog signal frequency of 1 GHz with the 50 dB SNR, the equivalent holding time constant of 200 fs needs to be chosen. The results of the research allow us to choose more optimally the THC characteristics depending on the needed signal processing frequency and the THC precision. Ill. 6, bibl. 7 (In English; summaries in English, Russian and Lithuanian).

## **V. Ясонис, А. Й. Марцинкявичюс. Моделирование переходных процессов в быстродействующих схемах слежения и хранения // Электроника и электротехника. – Каунас: Технология, 2008. – № 3(83). – С. 59–62.**

Анализируются динамические погрешности устройства слежения и хранения (УСХ) для аналого-цифровых преобразователей (АЦП) широкополосных сигналов. Представлены временные диаграммы выходных сигналов в зависимости от схемотехнических и топологических конструктивных электрических параметров УСХ для 8 и 10 разрядных АЦП. Установлено, что при частоте квантования 5 ГГц оптимальные пределы постоянной времени хранения сегмента сигнала составляет порядка 150–500 фс. При этом точность УСХ - 0,5 младшего значащего разряда (МЗР) для 8 разрядного АЦП и 0,75 МЗР для 10 разрядного АЦП. При этой частоте, изменение конструктивной индуктивности от 0,05 до 0,2 наногенри незначительно влияет на точность преобразования сигнала. Приведены расчетные зависимости относительной динамической погрешности УСХ от частоты входного сигнала при различных значениях линейного участка передаточной характеристики дифференциального усилителя и величины постоянной времени хранения сигнала. В результате исследования установлено, что для линейного участка передаточной характеристики дифференциального усилителя 0,05 В, постоянной времени хранения 200 фс, максимальной частоте спектра входного сигнала 1 ГГц, отношение сигнал/шум составляет 50 дБ. Полученные результаты исследования позволяют при разработке быстродействующих УСХ более оптимально подобрать их параметры в зависимости от частоты аналогового входного сигнала и необходимой точности АЦП. Ил. 6, библи. 7 (на английском языке; рефераты на английском, русском и литовском яз.).

## **V. Jasonis, A. J. Marcinkevičius. Pereinamųjų procesų modeliavimas sparčiuosiuose sekimo ir laikymo grandynuose // Elektronika ir elektrotechnika. – Kaunas: Technologija, 2008. – Nr. 3(83). – P. 59–62.**

Išanalizuotos sekimo ir laikymo grandyno (SLG) dinaminės paklaidos sinusinio signalo sekimo veikoje. Pateiktos išėjimo signalų laiko diagramos, priklausančios nuo schemos vidinių ir topologinio grandyno konstrukcinių elektrinių parametrų. Pateikti modeliavimo rezultatai, kai SLG skirtas 8 ir 10 bitų ASK, esant dviejų dydžių parazitinių konstrukcinių parametrų rinkiniui. Nustatyta, kad, kai SLG taktavimo sparta 5 GHz, tinkamiausia laikymo trukmės konstanta yra (120–500) fs. Tokiu atveju SLG tikslumas apie 0,5 mažiausio reikšminio skaičiaus (MRS) 8 bitų ASK ir apie 0,75 MRS 10 bitų ASK. Padidinus parazitinių induktyvumų vertes nuo 0,05 nH iki 0,2 nH, SLG tikslumas mažai pablogėjo. Kai stiprintuvų perdavimo charakteristikos tiesinės dalies ilgis yra 0,05 V, norint gauti analoginio įėjimo signalo dažnį 1 GHz, esant 50 dB signalo ir triukšmo santykiui, reikia parinkti ekvivalentinę laikymo trukmės konstantą 200 fs. Gauti tyrimo rezultatai leidžia, kuriant sparčius ASK, optimaliau parinkti jų parametrus priklausomai nuo analoginio įėjimo signalo dažnio ir reikiamo ASK tikslumo. Il. 6, bibl. 7 (anglų kalba; santraukos anglų, rusų ir lietuvių k.).

DOI: 10.5755/j02.eie.11078