

Ultrasonic Clearing Technology of Electronics Products

V. L. Lanin

Department of Electronic Technique and Technology, Belarus State University of Informatics and Radioelectronics, P. Brovki str. 6, 220013, Minsk, Belarus, phone: +375 017 2938888; e-mail: vlanin@bsuir.unibel.by

V. S. Tomal

RJE "Optical machine-tool building and vacuum plants", Filimonov str. 25, 220114, Minsk, Belarus, phone: +375 017 2643180; e-mail: os_vt@mail.belpak.by

Introduction

The analysis of the refusals reasons of electronics products shows, that their fourth part falls at a share of bad quality of surfaces and contact connections clearing [1]. Washing substances in electronics always were organic solvents. Manual clearing results in a significant amount of spoilage, a traumatism, emissions vapor solvents in an atmosphere and to environmental contamination. The basic lack of spirits: them fire-and explosion hazard. Chlorinated hydrocarbons are toxic, possess cancerogenic and mutagen action, form could and recycling waste products by a method of a burial place demand. Freons destroy an ozone cloud and strengthen a hotbed effect. Therefore the problem of creation of new safe washing compositions, ecologically safe technological processes and the equipment for clearing products is actual.

Alternative to organic solvents and freons is ultrasonic clearing in water solutions of superficially active substances (SAS). Influence ultrasonic of fields on liquid environments causes in them processes cavitation, and also macro-and microstreams in volume of a liquid, adjoining to radiate surfaces of a bath. Gas cavities cracks accompanied by formation of shock

Processing of ultrasonic clearing

Destruction superficial films pollution in a liquid occurs in result cavitation and the directed acoustic currents. In this connection necessity of maintenance of uniformity cavitation areas is proved. Distribution gas bubbles in cavitation areas in most cases non-uniformly. Around of slamming bubbles there is a process of duplication of germs therefore there are congestions bubbles the various form. Presence of such congestions essentially breaks uniformity of distribution bubbles in the liquid environment.

The problem of reception in technological volume of clearing baths uniform cavitation areas is

very important. In most frequently used designs as a bottom of a bath the radiating diaphragm ultrasonic the converter serves. Distribution of the acoustic pressure created by such systems, extremely non-uniformly - up to 50 %. In the center of a bath above a diaphragm pressure accepts the maximal value and decreases to edge of a membrane. Sometimes for maintenance of uniformity of ultrasound use the crooking fluctuation diaphragm raised by system distributed ultrasonic of converters, attached in maximums crooking fluctuations of a plate. Acoustic pressure above such system non-uniformly and also has maxims and minima. Assembly and adjustment of such systems is difficult.

At ultrasonic clearing electronic and optic-electronic products by the basic requirement showed to technological systems, high uniformity of ultrasound influence on products is. Therefore for excitation of ultrasonic fluctuations use batch piezoelectric converters capacity 50 - 100 Wt, fixed on lateral walls and the bottom of a bath in the certain order [4]. In this case efficiency and stability of work of converters depends on width of a strip of transformation as in the greater degree are blocked frequency bands separate converters that allows to compensate inevitable disorder of their own resonant frequencies.

The modular system of the distributed converters established in chessboard order as a lattice of triangular structure with length of the party, multiple $n \lambda / \sqrt{3}$, where n - integers 1, 2, 3... is perspective; λ - length of ultrasound in liquid [5] environment. Such arrangement of converters creates uniform on the area ultrasonic field at three-phase excitation due to superposition of waves, radiate various converters. Distance center-to-center in-group multiply to length of a wave ultrasound λ . Converters in each group electrically are connected in parallel and connected to corresponding channels A, B or C modular ultrasonic generators (fig. 1). Ultrasonic generators create peak and frequency modulation of a target signal by frequency of 100 Hz. The target signal represents the sum of three harmonious

fluctuations with the basic frequency ω and lateral frequencies ($\omega + 100$) Hz and ($\omega - 100$) Hz.

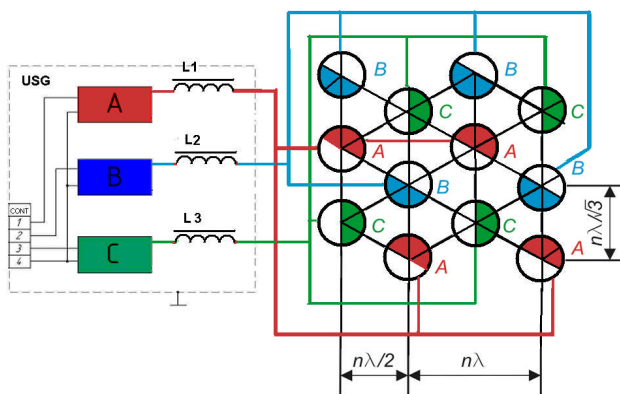

Fig. 1. The modular ultrasonic generator circuit: A, B, C – channels; L1, L2, L3 – coordination throttles, A,B,C – piezoelectric converters

The effect periodic deviation frequency averages a near ultrasonic field as a result of periodic change interference pictures. Entrance resistance of converters form together with compensating inductions resonant contours adjusted on working frequency of the generator. Changes of technological conditions (temperature and structure of a solution, presence of the cartridge with details) change entrance resistance of the converter. With a correct choice of a working point on dependence of full entrance resistance on frequency provide frequency trim.

Signals on an output of ultrasonic generators are shifted on a phase on 120° . The area of the maximal acoustic pressure consistently moves from the converter A to B and from B to C in each group. There are directed streams of a liquid from zone of the greater acoustic pressure in zone of smaller pressure. Whirlwind macrostreams alongside with microstreams in a viscous boundary layer near to obstacles intensify processes diffusion and dissolution of pollution.

Ultrasonic installations for removal of pollution include various baths on design, which are used for clearing, both in landlocked, and in the flowing environment. Baths for flowing (fig. 2, a) and landlocked and washing environments (fig. 2, б) differ that the first are equipped let over-flow pocket. For increase of efficiency of an exchange of the washing environment in working volume of a bath, submission of a solution baths through a number of apertures of small diameter (3 - carry out a countercurrent from above and from below 6 mm) on depth 8 - 15 mm. Such bath for clearing in the flowing environment possesses the big uniformity of distribution cavitation pressure as washing streams have laminar character.

The capacity of baths gets out depending on overall dimensions of details or from the set productivity of installation and necessary time of clearing. For uniform influence of ultrasound on object of clearing the linear sizes of a bath in cross-section section are multiple to half of length of ultrasonic wave, and the height of a level of the washing environment is multiple to length of a wave.

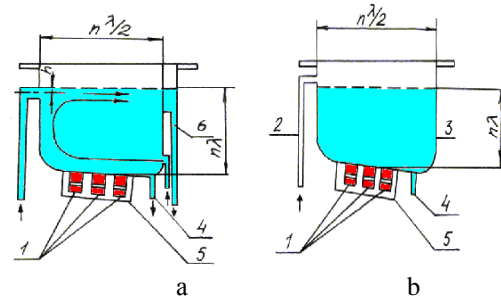

Fig. 2. Ultrasonic baths of clearing: 1 – converters, 2 – let over-flow a branch pipe, 3 – the case, 4 – a drain branch pipe, 5 – the screen; 6 – let over-flow pocket

At designing baths the choice of a way of fastening of converters to a bath as it defines durability of a bath and efficiency of its work is important. Converters fix epoxy compound, with welding, and also the combined way, which does not create zones of a congestion of pollution and provides the most full transfer of ultrasound to washing environment. In this case pulling together bolt it is welded on a wall of a bath, and the glutinous seam is mechanically unloaded.

Cases of baths make corrosion-proof Cr-Ni steels or titanic alloys, which possess high chemical and cavitation stability. Internal surfaces of walls of baths polish, as defects on their surface are the centers of adhesion of molecules of air, which operate as germs cavitation. The roughness of a radiating surface results in reduction of threshold value of oscillatory speed at which in the washing environment starts to develop cavitation that reduces efficiency of transformation of electric energy in acoustic.

Cavitation fields in ultrasonic baths

Cavitation intensity in liquid environments estimate on comparison of samples parameters before influence on them cavitation. Test samples fix in the certain place of working volume and, keeping time of endurance to constants, define loss of weight. The mistake of a method makes up to 25 % that speaks heterogeneity cavitation areas and other random factors [6]. The estimation of erosive activity is facilitated, if as a sample to take a thin aluminum foil thickness of 0,05 mm and to estimate the area of its destruction on various distances up to a radiator (fig. 3). Lacks of a method consist in duration of measurements and in absence of the continuous control of cavitation process.

Cavitation field in liquids has complex spectral structure as during the casual moments of time arises and the set bubbles slams and the acoustic radiation caused by them is shown as broadband noise with a spectrum in a strip up to hundreds kHz. On a background of a spectrum cavitation noise discrete subharmonics components, which characterize occurrence cavitation, are observed [7]. The spectral analysis of the form of signals decomposition in number Fourier of a harmonic of high frequencies nf_0 ($n=1, 2, 3$), subharmonics $nf_0/2$, $nf_0/3$, $nf_0/4$ and the "white" noise generated cavitation bubblers of the various resonant sizes.

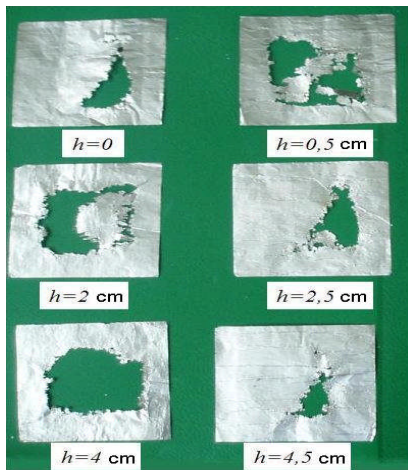

Fig. 3. Samples of the destroyed foil on various distances from a radiator

Spectral research cavitation noise in a range of MHz of 20 kHz - 50 with the help of the analyzer of a spectrum and the gauge, placed in cavitation area of a liquid, that the maximal growth in a spectrum at increase generate capacity gives continuous noise, and also subharmonics. The greatest spectral density cavitation noise is in a frequency trip from 20-th up to 40-th harmonic of the basic converter frequency.

In the beginning at adjustment of a bath estimate fluctuation amplitudes of each converter with the help of a contact vibrations measuring instrument (Fig. 4, a). Cavitation pressure in the liquid environment estimate intensity on square-law size of a level of noise in a range of its greatest spectral density with the help cavitometr [8], consisting of the gauge, the strip filter, the square-law detector and the recording device. Cavitometr (fig. 4, b) measures cavitation pressure from 5 up to $5 \cdot 10^4$ Pa in a range of frequencies 18 - 60 kHz with accuracy $\pm 10\%$. The strip filter under Chebushev circuit of the third order allocates a part of a spectrum of a signal, characteristic for cavitation pulses. Instrument readings register through 1-2 with when cavitation process accepts steady character.



Fig. 4. Measuring vibrations instrument (a) and cavitometr (b)

Dependences cavitation pressure from temperature of environment and concentration SAS in a solution are investigated. With rise in temperature cavitation pressure decreases, as elasticity pair in cavities raises and their kinetic energy that results (Fig. 6) in reduction of shock waves intensity is reduced. In parallel there is a formation new, basically filled the ferry bubbles, that results in expansion of

cavitation area and to reduction of non-uniformity of its distribution. Speed of decrease cavitation pressure in process of growth of temperature of the washing environment depends on its physical and chemical properties. So, for clean water (1 and 2) speed of change is less than dependence, than for water solutions SAS (dependences 3 and 4). SAS reduce force of a superficial tension that results in decrease in a threshold cavitation, to growth of number bubbles and to increase of uniformity cavitation fields. However reduction of force of a superficial tension reduces slam speed cavitation bubbles and microshock cavitation action. With growth of temperature influence SAS grows (curves 3 and 4).

With increase in concentration SAS their influence amplifies (Fig. 5), however to increase it over 10 % is inexpedient in view of difficulty of the subsequent removal. Thus, measuring cavitation pressure is possible to establish such temperature modes at which efficiency of influence OUSE of fluctuations and SAS will be optimum. For OUSE of clearing the optimum temperature of washing environments on basis water solutions SAS is in limits 50-60°C, and concentration SAS-of 3-4 %.

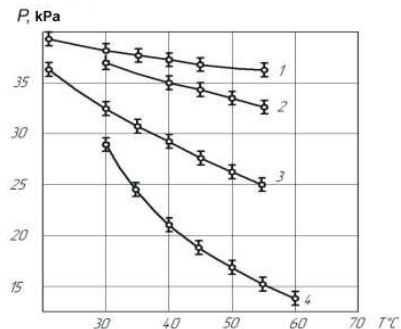

Fig. 5. Dependences cavitation pressure from temperature and concentration SAS: 1, 2 - 0 %, 3 - 1,5 %, 4 - 3 %

Non-uniformity cavitation fields in working volume of a bath with a modular arrangement of radiators on the area of bath averages 3-5 %, and on depth of 6-10 %.

Automated ultrasonic clearing complex

Modern automated complex ACC-1 will consist of six clearing models equipped with mechanisms of fast immersing of cartridges with details (10-15 mm / c) and slow extraction (1,0 mm/ c), the module of the drying, two auto operators, the rack of an electric equipment and a control system on the basis of the programmed controller such as CJ1W (Fig. 6). The control system according to algorithm provides performance of the following functions: input, indication and change of technological parameters; an output{exit} in a zero point of both auto operators and moving of mechanisms swing, dry and ultrasound; inclusion of heating in baths and the module of drying, maintenance of temperature at the set level; carry of cartridges from one bath in another. The software of a control system allows to form the managing program for technological processes with the different algorithms of work distinguished by sequence of passage of baths with washing solutions, time of clearing, temperature of environment. The range of tem-

peratures - from 20 up to 80°C, makes productivity of a complex up to 4500 pieces/hour.



Fig. 6. The automated clearing complex ACC-1

The serial automated clearing lines of electronic and electron-optical products have allowed to raise essentially labor productivity, to improve working conditions, to lower losses and to exclude application of fire-dangerous substances.

References

1. **Savage T.** Ultrasonic cleaning in industry // *Wire Industry*. – 2005. – No. 6. – P. 424–426.
2. **Fuchs F. J.** The Key to Ultrasonics–Cavitation and Implosion // *Precision Cleaning*. – 1995. – No. 3(10). – P. 13–17.
3. **Kundas S., Lanin V., Dostanko A., Tyavlovsky M., Bursky V., Tomal V.** Ultrasonic Processes in Electronics Production // *Minsk: Bestprint*, 2003. – Vol. 2. – 224 p.
4. **Tomal V. S.** Ultrasonic Equipment for Contaminations Removal Processes from Microrelief Surfaces of Electro-optical Units // *Doklady of the BSUIR*. – 2007. – No.1. – P. 94–99.
5. **Tomal V. S.** Automated Technological Complex for Ultrasonic Clearing of Electron-optical Elements // *Materials. Technologies. Tools*. – 2007. – No. 1, Vol. 12. – P. 102–107.
6. **Ilyichev V. I., Koretz V. L., Melnicov N. P.** Spectral characteristics of acoustic cavitation // *Ultrasonics*. – 1989. – No 27. – P. 357–361.

Submitted for publication 2007 12 11

V. L. Lanin, V. S. Tomal. Ultrasonic Clearing Technology of Electronics Products // Electronics and Electrical Engineering. – Kaunas: Technologija, 2008. – No. 3(83). – P. 49–52.

Environmental problems in electronics have caused heightened interest to processes and devices of ultrasonic clearing of electronic products. For removal of proof pollution from surfaces of products in the liquid environment the directed acoustic currents are created and uniformity cavitation fields in ultrasonic bath is provided. The automated lines of clearing of electronic and electron-optical products have allowed raising essentially labor productivity, to improve working conditions, to lower losses and to exclude application of fire-dangerous substances. Ill. 6, bibl. 6 (in English; summaries in English, Russian and Lithuanian).

В. Л. Ланин, В. С. Томаль. Технология ультразвуковой очистки изделий электроники // Электроника и электротехника. – Каунас: Технология, 2008. – № 3(83). – С. 49–52.

Экологические проблемы в электронике вызвали повышенный интерес к процессам и устройствам ультразвуковой очистки электронных изделий. Для удаления стойких загрязнений с поверхностей изделий в жидкой среде сформированы направленные акустические течения и обеспечена равномерность кавитационного поля в ультразвуковой ванне. Автоматизированные линии очистки электронных и электронно–оптических изделий позволили существенно повысить производительность труда, улучшить условия труда, снизить потери и исключить применение пожароопасных веществ. Ил. 6, библи. 6 (на английском языке; рефераты на английском, русском и литовском яз.).

V. Lanin, V. Tomal. Ultragarsinė elektroninių gaminių valymo technologija // Elektronika ir elektrotechnika. – Kaunas: Technologija, 2008. – Nr. 3(83). – P. 49–52.

Ekologinės problemos elektronikoje skatina labiau domėtis ultragarsinio elektroninių gaminių valymo įranga. Norint pašalinti teršalus nuo gaminių paviršiaus, skystoje terpėje formuojamos kryptinės akustinės srovės ir užtikrinamas kavitacinio lauko tolygumas ultragarso vonelėje. Automatizuotos elektroninių ir elektroninės optikos gaminių valymo linijos leido gerokai padidinti darbo našumą, pagerinti darbo sąlygas, sumažinti nuostolius ir nenaudoti degių medžiagų. Il. 6, bibl. 6 (anglų kalba; santraukos anglų, rusų ir lietuvių k.).

DOI: 10.5755/j02.eie.11076