

## Performance Measures of Priority Queuing Data Network Node with Unreliable Transmission Channel

R. Rindzevičius, M. Augustaitis, P. Tervydis, V. Pilkauskas

Department of Telecommunications, Kaunas University of Technology

Studentų str. 50-423, LT-51368 Kaunas, Lithuania, e-mail: Ramutis.Rindzevicius@ktu.lt

### Introduction

The use of quality of service mechanisms to provide prioritization for various traffic types is a key element needed for voice and data network convergence [1]. However, it is not sufficient if the networks components are unreliable. The focus of this article is to address the reliability aspects to priority traffic transmission over an unreliable channel. Analytical and simulation methods are applied to analysis priority queuing data network. The quality of data packet transmission is primarily a function of data packet loss and delay. The need to support real-time service has driven the development of priority data control mechanisms and technologies [2]. The objective is always to guarantee prioritization of voice and video flows and service providers need reliable and high performance networks.

This article analysis how priority queuing network an unreliable transmission channel impacts the data packets loss and delays. Analytical model is based on Markov chains and analyzes unreliable channel with exponential times between failures and times to restorations. A typical time between failures of data network components is in range 10000-300000 hours and the failed component is recovered by reset, which typically takes several minutes, or replaced, which takes some hours [3]. To reduce channel failure impacts the channel is often redundant. There are many data network node reliability issues to be resolved in order to achieve acceptable reliability. High availability with extremely short interruptions in case of failure is needed for acceptable QoS in real-time dialog services such as telephony or video conferencing [3].

An asymmetric data network node with unreliable channels is investigated in reference [4].

In this paper we will propose the analytical models of data packets transmission with two different approaches: when transmission channel is trusty (without failures) and when the channel is unreliable.

In summary, we claim that the proposed models would be very worthwhile to analyze the processes on real-time services providing data network node.

### Analytical model for performance evaluation of reliable priority queuing network node

We will study telecommunication network queuing node, which uses one unreliable transmission channel to transmit low and high priority Poisson data flows, which are coming into the channel via two different FIFO buffers.

Let's suppose that two priorities Poisson data packets flows arriving to the buffers length  $K_1$  and  $K_2$  with rates  $\lambda_1$  and  $\lambda_2$  each. The transmission intensities of data packets over the channel are equal to the  $\mu_1$  – for high priority data packets and  $\mu_2$  – for low priority data packets respectively. Network node structure is given in Fig. 1.

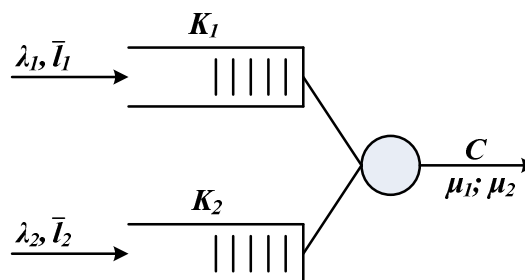
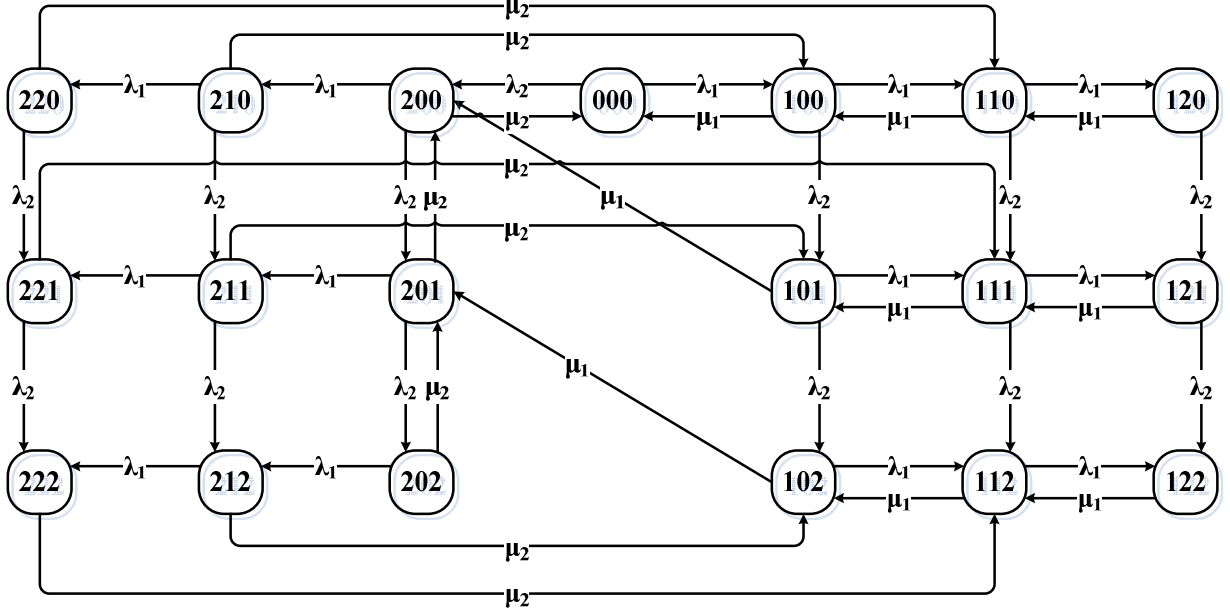

Fig. 1 Network queuing node structure with two separated buffers

System parameters:

- $\lambda_1$  – flow intensity of high priority data packets,
- $\lambda_2$  – flow intensity of low priority data packets,
- $\bar{l}_1$  – mean value of high priority data packet length,
- $\bar{l}_2$  – mean value of low priority data packet length,
- $K_1$  – buffer, which contains high priority data packets, size,
- $K_2$  – buffer, which contains low priority data packets, size,
- $C$  – data packet transmission constant bit rate in channel,
- $\mu_1, \mu_2$  – high and low priority data packet transmission intensities through the channel.



**Fig. 2.** Continuous time and discrete state Markov birth-death process of the network node with reliable transmission channel with two buffers

The data packet lengths  $l_1, l_2$  are exponentially distributed with mean values  $\bar{l}_1, \bar{l}_2$ :  $P(l_i \leq k) = 1 - e^{-k/\bar{l}_i}$ ,  $i=1,2$ ;  $k=0,1,2,\dots$ .

Data packets transmission intensities by channel are given by:  $\mu_i = C/l_i$ ,  $i=1,2$ .

Transmission durations of data packets through the channel:  $\tau_i = 1/\mu_i = l_i/C$ ,  $i=1,2$ .

System utilization parameter:  $\rho = (\lambda_1 + \lambda_2)/\mu$ , where mean value of data packets transmission intensity via channel  $\mu = (\mu_1 \cdot \lambda_1/(\lambda_1 + \lambda_2)) + (\mu_2 \cdot \lambda_2/(\lambda_1 + \lambda_2))$ .

Let's begin from the case with reliable data transmission channel. Both priorities data packets are accepted to the system until their buffers are not full. But low priority data packets are not served by the channel until the high priority buffer is not empty. That why we will need to make a model of birth-death process for such Markov queuing system measures evaluation. Each system state may be described by vector of three parameters  $X, Y$  and  $Z$ .

$X$  describes channel states: 0 – channel is free; 1 – channel is transmitting high priority data packet; 2 – channel is transmitting low priority data packet.

$Y$  – number of high priority packets in the first buffer in our case 0, 1 or 2, when buffer capacity  $K_1=2$  packets.

$Z$  – number of low priority packets in the second buffer in our case 0, 1 or 2, when buffer capacity  $K_2=2$  packets.

System state transition diagram on Fig. 2 is build for a system, which buffers sizes are  $K_1=K_2=2$  data packets. Therefore, we will have to investigate system with data packet losses. Data packet loss probability basically depends from buffers capacities and throughput of the channel.

Using global balance concept, we can write down equations system (1) to evaluate state probabilities  $P_{XYZ}$ :

$$\begin{cases}
 P_{220} \cdot (\lambda_2 + \mu_2) - P_{210} \cdot \lambda_1 = 0; \\
 P_{221} \cdot (\lambda_2 + \mu_2) - P_{211} \cdot \lambda_1 - P_{220} \cdot \lambda_2 = 0; \\
 P_{222} \cdot \mu_2 - P_{212} \cdot \lambda_1 - P_{221} \cdot \lambda_2 = 0; \\
 P_{210} \cdot (\lambda_1 + \lambda_2 + \mu_2) - P_{200} \cdot \lambda_1 = 0; \\
 P_{211} \cdot (\lambda_1 + \lambda_2 + \mu_2) - P_{201} \cdot \lambda_1 - P_{210} \cdot \lambda_2 = 0; \\
 P_{212} \cdot (\lambda_1 + \mu_2) - P_{202} \cdot \lambda_1 - P_{211} \cdot \lambda_2 = 0; \\
 P_{200} \cdot (\lambda_1 + \lambda_2 + \mu_2) - P_{000} \cdot \lambda_2 - P_{101} \cdot \mu_1 - P_{201} \cdot \mu_2 = 0; \\
 P_{201} \cdot (\lambda_1 + \lambda_2 + \mu_2) - P_{200} \cdot \lambda_2 - P_{102} \cdot \mu_1 - P_{202} \cdot \mu_2 = 0; \\
 P_{202} \cdot (\lambda_1 + \mu_2) - P_{201} \cdot \lambda_2 = 0; \\
 P_{000} \cdot (\lambda_1 + \lambda_2) - P_{100} \cdot \mu_1 - P_{200} \cdot \mu_2 = 0; \\
 P_{100} \cdot (\lambda_1 + \lambda_2 + \mu_1) - P_{000} \cdot \lambda_1 - P_{110} \cdot \mu_1 - P_{210} \cdot \mu_2 = 0; \\
 P_{101} \cdot (\lambda_1 + \lambda_2 + \mu_1) - P_{100} \cdot \lambda_2 - P_{111} \cdot \mu_1 - P_{211} \cdot \mu_2 = 0; \\
 P_{102} \cdot (\lambda_1 + \mu_1) - P_{101} \cdot \lambda_2 - P_{112} \cdot \mu_1 - P_{212} \cdot \mu_2 = 0; \\
 P_{110} \cdot (\lambda_1 + \lambda_2 + \mu_1) - P_{100} \cdot \lambda_1 - P_{120} \cdot \mu_1 - P_{220} \cdot \mu_2 = 0; \\
 P_{111} \cdot (\lambda_1 + \lambda_2 + \mu_1) - P_{101} \cdot \lambda_1 - P_{110} \cdot \lambda_2 - P_{121} \cdot \mu_1 - P_{221} \cdot \mu_2 = 0; \\
 P_{112} \cdot (\lambda_1 + \mu_1) - P_{102} \cdot \lambda_1 - P_{111} \cdot \lambda_2 - P_{122} \cdot \mu_1 - P_{222} \cdot \mu_2 = 0; \\
 P_{120} \cdot (\lambda_2 + \mu_1) - P_{110} \cdot \lambda_1 = 0; \\
 P_{121} \cdot (\lambda_2 + \mu_1) - P_{111} \cdot \lambda_1 - P_{120} \cdot \lambda_2 = 0; \\
 P_{122} \cdot \mu_1 - P_{112} \cdot \lambda_1 - P_{121} \cdot \lambda_2 = 0; \\
 \sum_{allXYZ} P_{XYZ} = 1.
 \end{cases} \quad (1)$$

We now proceed to find system performance measures such as:

a) high and low priority data packets loss probabilities:

$$P_{1Loss} = \sum_{allXZ} P_{X2Z}, \quad (2)$$

$$P_{2Loss} = \sum_{allXY} P_{XY2}; \quad (3)$$

b) mean number of high and low priority data packets in buffer waiting to be served:

$$\overline{N}_{q1} = \sum_{allY=1,2} Y P_{XYZ}, \quad (4)$$

$$\overline{N}_{q2} = \sum_{allZ=1,2} Z P_{XYZ}; \quad (5)$$

c) mean value of waiting times for the high and low priority packets in the queue:

$$\overline{W}_1 = \frac{\overline{N}_{q1}}{\lambda_1(1 - P_{1Loss})}, \quad (6)$$

$$\overline{W}_2 = \frac{\overline{N}_{q2}}{\lambda_2(1 - P_{2Loss})}. \quad (7)$$

### Analytical model for performance evaluation of unreliable priority queuing network node

Now let's analyze the case when the transmission channel is unreliable. Consider that the channel failure intensity  $\gamma$  and the channel repair rate  $r$  are distributed

exponentially we can draw a Markov system state transition diagram as shown in Fig. 3.

The Markov chains state for the node with unreliable transmission channel has one more state ( $P_{XYZJ}$ ) vector parameter  $J$ . Parameter  $J$  shows is the transmission channel working properly ( $J=0$ ) or are there some channel failures ( $J=1$ ). Mean time between channel failures (MTBF) is a basic measure of the system reliability. It is typically represented in to the expected number of operating hours before the channel fails. The channel failure rate  $\gamma$  is the inverse of the mean time between failures.

The channel repair rate  $r$  is the inverse of the mean time to repair. Mean time to repair (MTTR) or recover is the expected time to recover channel from a failure. This may include the time it takes to diagnose the failure, the time it takes to get a repair technician onsite, and the time it takes to physically repair the channel.

The mean time between channel failures and the mean time to repair can be modeled as an exponentially distributed random variable. Equations (8, 9) illustrate *MTBF* and *MTTR* variables distributions

$$P(MTBF \leq t) = 1 - e^{-\gamma t}, \quad 0 > t < \infty, \quad (8)$$

$$P(MTTR \leq t) = 1 - e^{-rt}, \quad 0 > t < \infty. \quad (9)$$

Consider, that our system is a continuous time and discrete Markov chain and then using global balance concept, we can write down equations system (10) to evaluate states probabilities  $P_{XYZJ}$ .

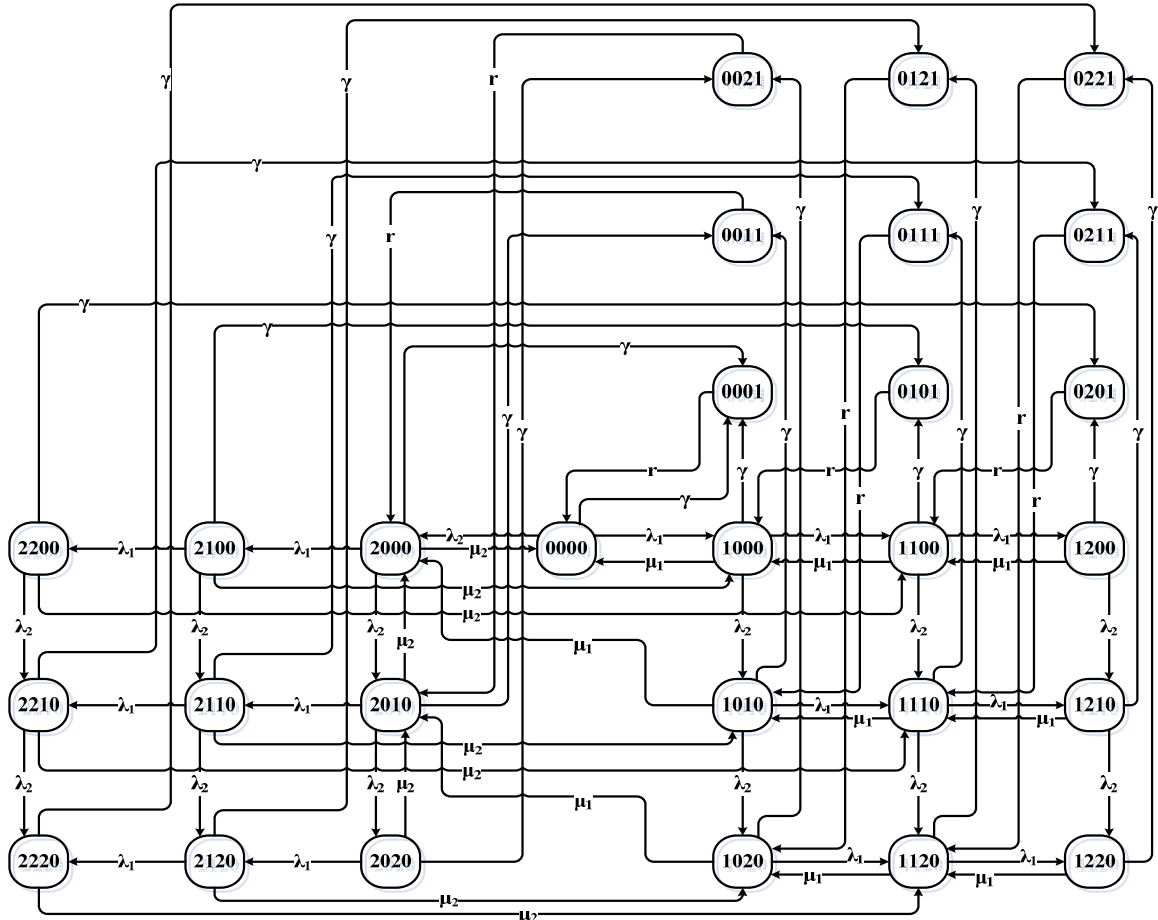

**Fig. 3.** Continuous time and discrete state Markov birth-death process of the network node with unreliable transmission channel and two buffers

$$\begin{cases}
P_{0000} \cdot (\lambda_1 + \lambda_2 + \gamma) - P_{1000} \cdot \mu_1 - P_{2000} \cdot \mu_2 - \\
- P_{0001} \cdot r = 0; \\
P_{1000} \cdot (\lambda_1 + \lambda_2 + \mu_1 + \gamma) - P_{0000} \cdot \lambda_1 - P_{1100} \cdot \mu_1 - \\
- P_{2100} \cdot \mu_2 - P_{0101} \cdot r = 0; \\
P_{1100} \cdot (\lambda_1 + \lambda_2 + \mu_1 + \gamma) - P_{1000} \cdot \lambda_1 - P_{1200} \cdot \mu_1 - \\
- P_{2200} \cdot \mu_2 - P_{0201} \cdot r = 0; \\
P_{1200} \cdot (\lambda_2 + \mu_1 + \gamma) - P_{1100} \cdot \lambda_1 = 0; \\
P_{1010} \cdot (\lambda_1 + \lambda_2 + \mu_1 + \gamma) - P_{1000} \cdot \lambda_2 - \\
- P_{1110} \cdot \mu_1 - P_{2110} \cdot \mu_2 - P_{0111} \cdot r = 0; \\
P_{1110} \cdot (\lambda_1 + \lambda_2 + \mu_1 + \gamma) - P_{1010} \cdot \lambda_1 - \\
- P_{1100} \cdot \lambda_2 - P_{1210} \cdot \mu_1 - P_{2210} \cdot \mu_2 - P_{0211} \cdot r = 0; \\
P_{1210} \cdot (\lambda_2 + \mu_1 + \gamma) - P_{1110} \cdot \lambda_1 - P_{1200} \cdot \lambda_2 = 0; \\
P_{1020} \cdot (\lambda_1 + \mu_1 + \gamma) - P_{1010} \cdot \lambda_2 - P_{1120} \cdot \mu_1 - \\
- P_{2120} \cdot \mu_2 - P_{0121} \cdot r = 0; \\
P_{1120} \cdot (\lambda_1 + \mu_1 + \gamma) - P_{1020} \cdot \lambda_1 - P_{1110} \cdot \lambda_2 - \\
- P_{1220} \cdot \mu_1 - P_{2220} \cdot \mu_2 - P_{0221} \cdot r = 0; \\
P_{1220} \cdot (\mu_1 + \gamma) - P_{1120} \cdot \lambda_1 - P_{1210} \cdot \lambda_2 = 0; \\
P_{2000} \cdot (\lambda_1 + \lambda_2 + \mu_2 + \gamma) - P_{0000} \cdot \lambda_2 - \\
- P_{1010} \cdot \mu_1 - P_{2010} \cdot \mu_2 - P_{0011} \cdot r = 0; \\
P_{2100} \cdot (\lambda_1 + \lambda_2 + \mu_2 + \gamma) - P_{2000} \cdot \lambda_1 = 0; \\
P_{2200} \cdot (\lambda_2 + \mu_2 + \gamma) - P_{2100} \cdot \lambda_1 = 0; \\
P_{2010} \cdot (\lambda_1 + \lambda_2 + \mu_2 + \gamma) - P_{2000} \cdot \lambda_2 - P_{1020} \cdot \mu_1 - \\
- P_{2020} \cdot \mu_2 - P_{0021} \cdot r = 0; \\
P_{2110} \cdot (\lambda_1 + \lambda_2 + \mu_2 + \gamma) - P_{2010} \cdot \lambda_1 - P_{2100} \cdot \lambda_2 = 0; \\
P_{2210} \cdot (\lambda_2 + \mu_2 + \gamma) - P_{2110} \cdot \lambda_1 - P_{2200} \cdot \lambda_2 = 0; \\
P_{2020} \cdot (\lambda_1 + \mu_2 + \gamma) - P_{2010} \cdot \lambda_2 = 0; \\
P_{2120} \cdot (\lambda_1 + \mu_2 + \gamma) - P_{2020} \cdot \lambda_1 - P_{2110} \cdot \lambda_2 = 0; \\
P_{2220} \cdot (\mu_2 + \gamma) - P_{2120} \cdot \lambda_1 - P_{2210} \cdot \lambda_2 = 0; \\
P_{0001} \cdot (r + \lambda_1 + \lambda_2) - \gamma \cdot (P_{0000} + P_{1000} + P_{2000}) = 0; \\
P_{0101} \cdot (r + \lambda_1 + \lambda_2) - \gamma \cdot (P_{1100} + P_{2100}) - P_{0001} \cdot \lambda_1 = 0; \\
P_{0201} \cdot (r + \lambda_2) - \gamma \cdot (P_{1200} + P_{2200}) - P_{0101} \cdot \lambda_1 = 0; \\
P_{0011} \cdot (r + \lambda_1 + \lambda_2) - \gamma \cdot (P_{1010} + P_{2010}) - P_{0001} \cdot \lambda_2 = 0; \\
P_{0111} \cdot (r + \lambda_1 + \lambda_2) - \gamma \cdot (P_{1110} + P_{2110}) - \\
- P_{0011} \cdot \lambda_1 - P_{0101} \cdot \lambda_2 = 0; \\
P_{0211} \cdot (r + \lambda_2) - \gamma \cdot (P_{1210} + P_{2210}) - \\
- P_{0111} \cdot \lambda_1 - P_{0201} \cdot \lambda_2 = 0; \\
P_{0021} \cdot (r + \lambda_1) - \gamma \cdot (P_{1020} + P_{2020}) - P_{0011} \cdot \lambda_2 = 0; \\
P_{0121} \cdot (r + \lambda_1) - \gamma \cdot (P_{1120} + P_{2120}) - \\
- P_{0021} \cdot \lambda_1 - P_{0111} \cdot \lambda_2 = 0; \\
P_{0221} \cdot r - \gamma \cdot (P_{1220} + P_{2220}) - P_{0121} \cdot \lambda_1 - P_{0211} \cdot \lambda_2 = 0; \\
\sum_{allXYZ} P_{XYZJ} = 1.
\end{cases} \quad (10)$$

Using equation system (10) we can evaluate system performance measures such as:

a) high and low priority data packets loss probabilities:

$$P_{1Loss} = \sum_{allXZ} P_{X2Z0} + \sum_{allXYZ} P_{XYZ1}, \quad (11)$$

$$P_{2Loss} = \sum_{allXY} P_{XY20} + \sum_{allXYZ} P_{XYZ1}; \quad (12)$$

b) mean number of high and low priority data packets waiting in the buffers to be served:

$$\overline{N_{q1}} = \sum_{allXYZJ} Y \cdot P_{XYZJ}, \quad (13)$$

$$\overline{N_{q2}} = \sum_{allXYZJ} Z \cdot P_{XYZJ}; \quad (14)$$

c) mean value of the high and low priority data packets waiting time in the queue:

$$\overline{W_1} = \frac{\overline{N_{q1}}}{\lambda_1(1 - P_{1Loss})}, \quad (15)$$

$$\overline{W_2} = \frac{\overline{N_{q2}}}{\lambda_2(1 - P_{2Loss})}. \quad (16)$$

## Simulation results

Classical Markov model is simple and gives precise results only when incoming data packets flow process and transmission time is exponentially distributed. An exact system analytical model is very complicated when the buffers sizes are large, because Markov chains has a large number of states and more general system performance measures study may be achieved via simulation.

The simulation experiments were run on Pentium based PC with program developed using object oriented library for developing simulation models specified by aggregate approach [5] and C# programming language in the Microsoft.Net environment. To estimate the node performance measures each simulation was repeated with different parameters and simulation durations. Some investigation results of system performance measures achieved by means of proposed analytical and simulation methods are shown in Fig. 4,5,6,7. The incoming data packets flows to the network node are Poisson, and packet transmission time via channel distributed exponentially.

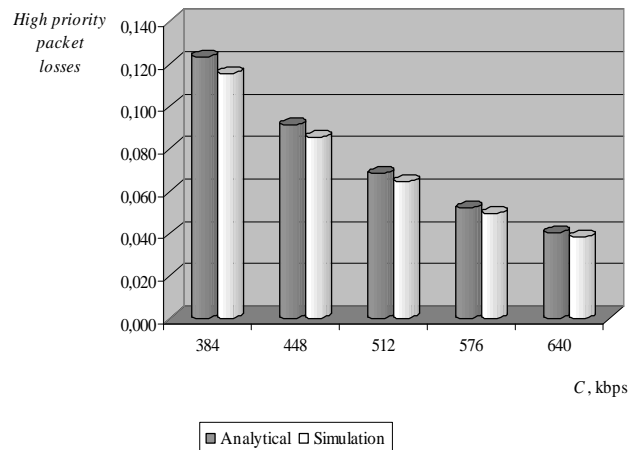
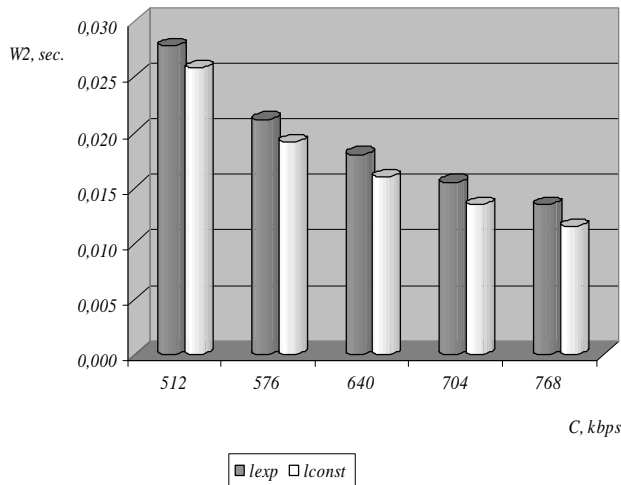

**Fig. 4.** High priority data packets loss as a function of transmission channel bit rate, when  $\lambda_1 = \lambda_2 = 25$ ,  $K_1 = K_2 = 2$  and  $\bar{l}_1 = \bar{l}_2 = 8kb$

Using simulation method we verified performance measures calculations by analytical model. As shown in

Fig. 4 the differences between calculated system performance measures and given by simulation are acceptable.

By means of simulation the network node performance measures are compared in Fig. 5, when data packets flows are Poisson and data packets lengths  $l_{exp}$  are exponentially distributed in one case, and when  $l_{const}$  is constant in other case.



**Fig. 5.** The mean waiting time in queue for low priority data packets as a function of transmission channel bit rate, when  $\lambda_1=\lambda_2=25$ ,  $K_1=K_2=2$  and  $\bar{l}_1 = \bar{l}_2 = 8kb$

Mean waiting time in queue for high priority data packets as a function of channel data transmission bit rate is illustrated on Fig. 6, when data packets length is distributed exponentially in one case and is constant in other case.

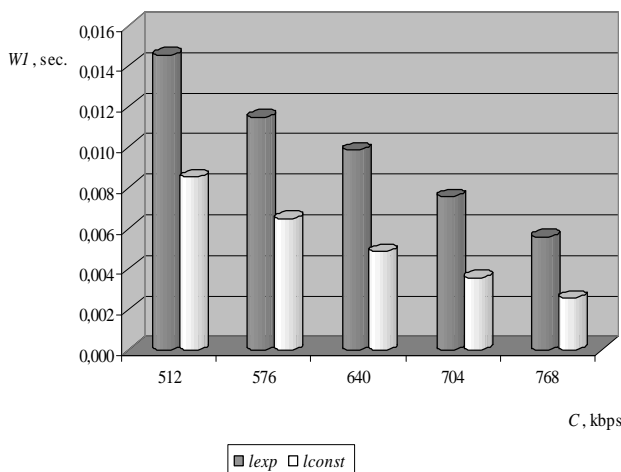

**Fig. 6.** The mean waiting time in queue for high priority data packets as a function of transmission channel bit rate, when  $\lambda_1=\lambda_2=25$ ,  $K_1=K_2=2$ ,  $r=0,003$ ,  $\gamma=0,00001$ , and  $\bar{l}_1 = \bar{l}_2 = 8kb$

Both priority data packets losses as a function of channel failure intensities  $\gamma$  are illustrated in Fig. 7.

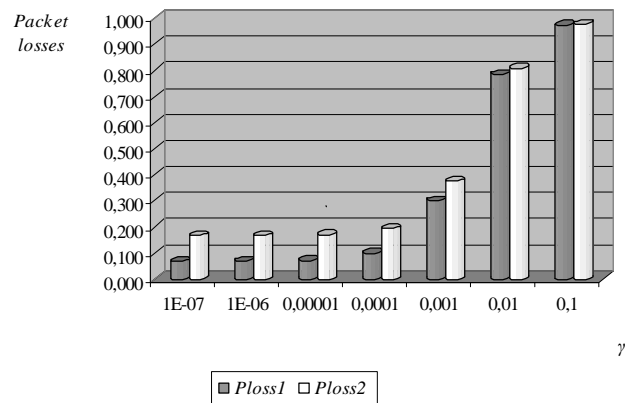

**Fig. 7.** High and low priority data packets loss  $P_{1loss}$ ,  $P_{2loss}$  as a function of channel failure rate  $\gamma$ , when  $\lambda_1=\lambda_2=25$ ,  $K_1=K_2=2$ ,  $\mu_1=\mu_2=64$ ,  $r=0,003$  and  $\bar{l}_1 = \bar{l}_2 = 8kb$

## Conclusions

Our proposed analytical and simulation models would be very worthwhile to analyze the processes on real-time services providing data network node. The Markov chains give possibility for easy and quick analysis of data packet transmission processes via an unreliable channel.

To improve network node performance measures for higher priority data packets it is necessary to use constant length of these packets, as shown in Fig. 6.

Data packet flows management is not necessary when transmission channel utilization is very low ( $\rho < 0,25$ ), in other case applying our proposed priority queuing system improve data network node performance measures.

For the exponential time between channel failures, failure rate  $r$  is independent of time. This means that in our proposed models channel failure rate for  $t$ -years old channel is the same as for a new channel.

The proposed models will help in evaluation of network nodes, which are transmitting data packets over unreliable channel with priority queuing.

## References

1. Johnson C.R., Kogan Y., Levy Y., Saheban F., Tarapore P. VoIP Reliability a Service Provider's Perspective // IEEE Communication Mag. – July, 2004. – Vol.42, No.7. – P. 48–54.
2. Park J. T. Resilience in GMPLS Path Management Model and Mechanism // IEEE Communication Mag. – July, 2004. – Vol. 42, No.7. – P. 128–135.
3. Schollmeier G., Winkler C. Providing Sustainable QoS in Next Generation Networks. IEEE Communication Mag. – June, 2004. – Vol. 42, No.6. – P. 102–107.
4. Žvironienė A., Navickas Z., Rindzevičius R. Performance Analysis of Unreliable Internet Node // Electronics and Electrical Engineering. – Kaunas: Technologija, 2007. – No.6(78). – P. 51–56.
5. Pranevičius H., Pilkauskas V. Object Oriented Library for Developing Simulation Models Specified by Aggregate Approach // In HMS2002, Italy, Genoa. – 2002. – P.122–127.

Submitted for publication 2007 12 20

**R. Rindzevičius, M. Augustaitis, P. Tervydis, V. Pilkauskas. Performance Measures of Priority Queuing Data Network Node with Unreliable Transmission Channel // Electronics and Electrical Engineering. – Kaunas: Technologija, 2008. – No. 3(83). – P. 37–42.**

We propose analysis of the priority queuing network node, which is using for transmission unreliable channel with constant bit transmission rate. For queuing system with two separated finite capacity buffers for each priority data packet flows we investigate performance measures in two cases: when transmission channel is reliable and when transmission channel is unreliable. The inter arrival time of high and low priority data packet flows and the transmission times of each priority data packet are exponentially distributed. The arrival process of each priority data packet is assumed to be independent of each other and the transmission process. Data packet leaves the buffer in first come first service manner. Non-preemptive priority queuing model is analyzed. Research is in progress to develop analytical and simulation models for such network data packets transmission node. Using our proposed analytical models we can easily evaluate system performance measures for each priority data packet, such as data packet losses, mean value of waiting time in buffer, mean number of data packets in queue, mean number of data packets in the system. The results from analytical and simulation model of some performance measures are taken in figures. The processes in the priority queuing network node are based on the Markov chains. The proposed analytical system models are suitable for analysis network node with finite data packets buffer. When the system buffer capacity is high analytical model for such queuing system node becomes very complicated. Simulation method allows investigate system with large capacities and exponential or constant data packets arrival process when transmission time so is exponential or constant. Our proposed analytical and simulation models would be very worthwhile to analyze the processes on real-time services providing data network node. Ill. 7, bibl. 5 (in English; summaries in English, Russian and Lithuanian).

**P. Риндзявичюс, М. Аугустайтис, П. Тервидис, В. Пилкаускас. Производительность узла сети приоритетного обслуживания очереди с ненадежным каналом передачи // Электроника и электротехника. – Каунас: Технология, 2008. – № 3(83). – С. 37–42.**

Предложенная модель анализа узла сети передачи данных, использующего для передачи данных ненадежный канал с постоянной скоростью передачи данных. Система ожидания имеет два отделенные буфера конечной ёмкости для каждого потока пакетов. Мы исследуем критерии качества работы системы в двух случаях: когда канал передачи надежен и когда канал передачи ненадежен. Время между поступающими потоками пакетов двух приоритетов и время передачи каждого из класса пакетов распределено экспоненциально. Процесс прибытия каждого из разных приоритетов пакетов данных, является независимым друг от друга, также как и от процесса передачи по каналу связи. Пакеты данных оставляют буфера согласно правилу FIFO. Разработаны аналитические модели для анализа узла сети передачи данных, использующего надёжный и ненадёжный каналы передачи данных. На основе аналитической модели легко оценить параметры передачи пакетов, такие как величина потерь пакетов, среднее время ожидания пакета в очереди, среднее число пакетов в очереди, среднее число пакетов в системе. На основе расчётов получены некоторые параметры качества передачи пакетов представлены в графиках. Анализ процессов, происходящих в узле сети передачи данных с ожиданием, базируется на цепях Маркова. Предложена аналитическая модель применима для анализа систем передачи данных с конечной ёмкостью буфера для пакетов. В результате исследования созданы аналитические модели для систем с ненадежными каналами передачи данных. Аналитическая модель становится довольно сложной, когда система имеет буфера большой ёмкости. В том случае для анализа системы передачи данных целесообразно применить метод моделирования. Ил. 7, библи. 5 (на английском языке, рефераты на английском, русском и литовском яз.).

**R. Rindzevičius. M. Augustaitis, P. Tervydis, V. Pilkauskas. Tinklo mazgo, aptarnaujančio prioritетines eiles, esant nepatikimam perdavimo kanalui, našumo rodikliai // Elektronika ir elektrotechnika. – Kaunas: Technologija, 2008. – Nr. 3(83). – P. 37–42.**

Pasiūlyta prioritетinio tinklo mazgo, naudojančio nepatikimą kanalą duomenims perduoti pastovia sparta, analizė. Eilių sistemos su dviem atskirais ribotos talpos buferiais kiekvieno prioritетo duomenų paketų srautui charakteristikų tyrimai atlikti dviem atvejais: kai perdavimo kanalas yra patikimas ir kai perdavimo kanalas yra nepatikimas. Laikai tarp tiek aukšto, tiek žemo prioritетo srautų paketų gavimo, bei kiekvieno prioritетo duomenų paketų perdavimo laikai yra pasiskirstę eksponentiškai. Bet kurio prioritетo duomenų paketų gavimo procesai yra nepriklausomi vienas nuo kito ir nuo paties perdavimo proceso kanale. Duomenų paketai palieka buferį pagal „pirmas įėjo – pirmas išėjo“ aptarnavimo taisyklę. Tyrimas atliktas norint sukurti analitinį ir imitacinį modelius tokiam duomenų perdavimo mazgui tinkle. Remiantis pasiūlytais matematiniais modeliais nesudėtinga įvertinti tiriamos sistemos našumo rodiklius, tokius kaip duomenų paketų praradimo tikimybė, vidutinė paketo laukimo eilėje trukmė, vidutinis paketų skaičius eilėje, vidutinis paketų skaičius sistemoje. Kai kurie rezultatai, gauti naudojant analitinį ir imitacinį modelius, yra pateikti grafikuose. Duomenų perdavimo .procesų tinklo mazge tyrimas remiasi Markovo grandinėmis. Pasiūlytas analizės modelis tinkamas sistemoms su ribotos talpos buferiais. Matematinis analitinis modelis tampa komplikuotu didinant buferio talpą ir šiam atvejui tikslinga panaudoti imitacinį modeliavimą. Pasiūlytas analitinis ir imitacinis modeliai yra naudingi norint išanalizuoti tinklo mazgą, teikiančią paslaugas realiu laiku. Il. 7, bibl. 5 (anglų kalba; santraukos anglų, rusų ir lietuvių k.).

DOI: 10.5755/j02.eie.11074