

Strain Measurements and Monitoring of Constructions

R. Kvedaras, V. Kvedaras

*Faculty of Electronics, Vilnius Gediminas Technical University,
Naugarduko str. 41, LT-03227 Vilnius, Lithuania, phone: +370 5 2744761; e-mail: vygaudas.kvedaras@el.vtu.lt*

Introduction

Buildings constructed of lightweight steel or concrete structures may have fallen and people might be lost. There were many accidents in the Europe recently – in Lithuania, Russia, Poland and Germany. Most frequently such failures occur during winter time when structures are exposed to additional load because of the snow which is accumulating on a roof, strong winds, and other exposures that overload the structures of the building.

It would be possible to save human lives if people were notified about a critical condition of building structures at least 10 – 20 minutes before collapse. In case approach of critical conditions is known at least before 1 – 2 hours it is even possible to keep a building itself. In this case for example it is possible to clear roof of a building from snow reducing critical loads or take other measures to reduce critical load. To define the load of a structure visually is rather difficult or even impossible. Therefore automatic signalling systems should be used. When parameters are exceeding threshold values, the system must set an alarm informing about arising danger. Development and implementation of such constant monitoring systems is not common yet. Authors are analyzing possibilities to build and use such systems.

Requirements for the Monitoring System

Basic constructive elements of a light structures used in various buildings are usually steel farms. To identify state of steel constructions automatically some parameter that can be changed to electrical value and then measured should be found. There is a rigid relation between durability and strain of a structure element in steel structures [1]. On the other hand, size of strain of a steel construction even in case of exposure of high loads is rather small. For example, if on a steel wire with cross-section $A = 4 \cdot 10^{-4} \text{ m}^2$ and length $l = 10 \text{ m}$ force of size $F = 1000 \text{ N}$ is applied the relative strain will be

$$\varepsilon_t = \frac{F}{EA} = 3.63 \cdot 10^{-5}. \quad (1)$$

Nevertheless steel has considerably higher opportunity to be deformed compared to concrete.

Concrete has considerably lower level of deformation before it is damaged and the strains to be measured for concrete would be even smaller compared to steel.

Strain can be measured using different techniques but most often as reliable and comparably low-cost solution resistive strain gauges that transform strain of the gauge to small change of its resistance are used.

In a complex building there are many carrying structures (or to say typical points of those structures) condition of which individually or jointly defines state of the building and as a result safety of operation of a building. Therefore monitoring system should be multi-channel and in most cases would have up to several hundreds or even more channels. Designers who know an arrangement of crucial structures should define installation points of strain gauges. Ideally mathematical model should be developed for the building defining crucial points and possible distribution of strains of these points. Therefore as one of the main parameters – strain parameter is measured in multiple points of a particular construction.

Concluding the aforementioned it is clear that monitoring system must a) determine the current condition of a building (structure, bridge, roof, etc.); b) define small changes of parameters (strain, vibration, acceleration, etc.) of physical quantities in specific points of a structure; c) transfer results of an estimation to the data-processing centre where results are processed, mathematical model of a structure is applied and result is carried out [2]. According to these results decision on the current condition of a structure is made (automatically or by human operator).

Multi-Channel Strain Measurement System

According to earlier experience further conclusions are made:

1. The system should be as simple as possible. In this case the quantity of error sources, amount of errors and therefore the price is relatively low ensuring relatively low-cost service of the system.

2. The system should have the feedback configuration ensuring that the influence of a part of error sources is compensated.

3. New products of electronics should be applied as much as possible in the system, often in non-standard application.

4. The system having many channels (up to several hundreds) should be designed in a block principle. In this case measurement units are placed in a relatively short distance from measurement points and the system can be easily adapted for different purposes.

It appears that the structure and problems to be solved for such systems are practically identical irrespective of measured parameters of a structure, an end result or a scope of the system. Therefore the block diagram of monitoring system is common for all similar applications. Created general block diagram of monitoring system is submitted on a Fig. 1.

The developed structure is highly agile – it is possible to measure and store various parameters of the object state, if necessary adding additional measuring units and number of measurement points can become quite high in order to connect to the system measurements of other objects or distant parts of the same object (e.g. parts of a large buildings, bridges, etc.). In this case it is possible to construct monitoring system gradually by adding additional measurement units upon necessity. It is possible to measure, accumulate data, and to analyze other important parameters of structure by only changing sensors, measuring units and/or programs.

In this system all signals from measuring units have digital form and can be transferred through the Internet or Intranet. It is possible to apply standard Wireless LAN and overcome one of the biggest lacks of the systems currently in use – communication lines that are relatively short and dealing with analogue signals. It is established that implementation of measurement lines in buildings (it is especially applicable in already build-up “working” buildings) is quite heavy and expensive job. At the same time measurement lines are mounted near cables of communications, electric supply and control lines are subject of influence of noises. It results to increase of errors and reduction of reliability of the system.

Therefore structure of the system that allows reducing of the measurement and communication lines is more preferable and cheaper at the same time. System proposed

ensures that location of separate measuring blocks can be established in immediate proximity from measured structures and at the same time length of connecting cables can be reduced reducing errors of measurement.

The system proposed is highly agile – each measuring unit with gauges can be used for measurements where it is needed up to several tens of gauges (32 in this case), amount of measuring units can be increased where more gauges are needed or a distance between gauges should be increased. The central server and workplace of tracking and management in this case can be established at any location that is the same or different from the building monitored. Furthermore the centralized system can monitor several buildings or even all required to monitor buildings of the city and build metropolitan area monitoring system. Later such system might be integrated into centralized emergency services system (such as 112, etc.).

Building of such systems based on strain measurement has several difficulties to deal with. Earlier it has been shown; that the size of deformation is rather small, therefore the change of strain-gauge resistance is also small:

$$\Delta R = RS\varepsilon_t, \quad (2)$$

where R – strain-gauge resistance; ε_t – strain of construction; S – sensitivity ratio.

For example in case of change of strain of steel farm is in range $\varepsilon_t = 10^{-6} \dots 10^{-3}$, strain-gauge resistance is $R = 120 \Omega$ and sensitivity ratio $S = 2$, the change of resistance of strain gauge is $\Delta R = (0.00024 \dots 0.24) \Omega$. It is a very small value and typically non-balanced Wheatstone bridges are used for such measurements. It has been shown that application of non-balanced Wheatstone bridge without feedback is not convenient for such type of applications where several strain gauges are connected to the same measurement unit [3, 4]. Nevertheless nearly all strain gauge measurement systems in the market are based on non-balanced Wheatstone bridge and therefore are struggling to expand systems as implementation, expansion and maintenance of such systems are costly. Authors have developed a digitally balanced Wheatstone bridge that allows implementation of the monitoring system proposed.

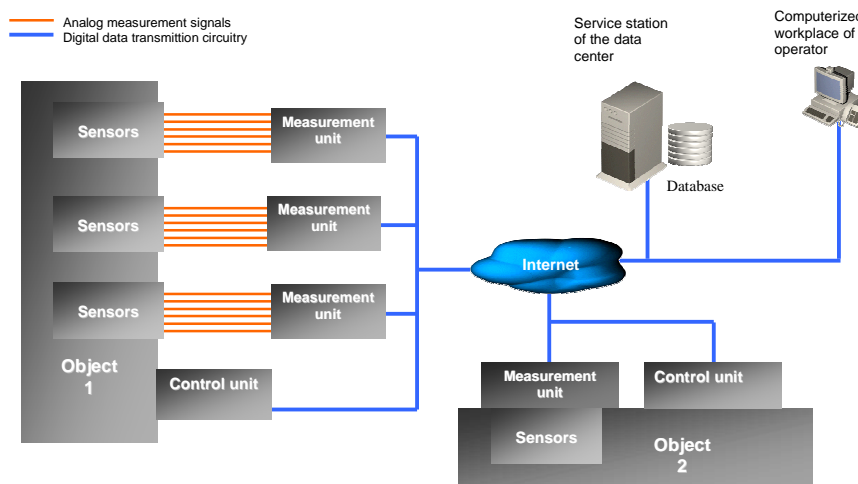

Fig. 1. Block diagram of monitoring system

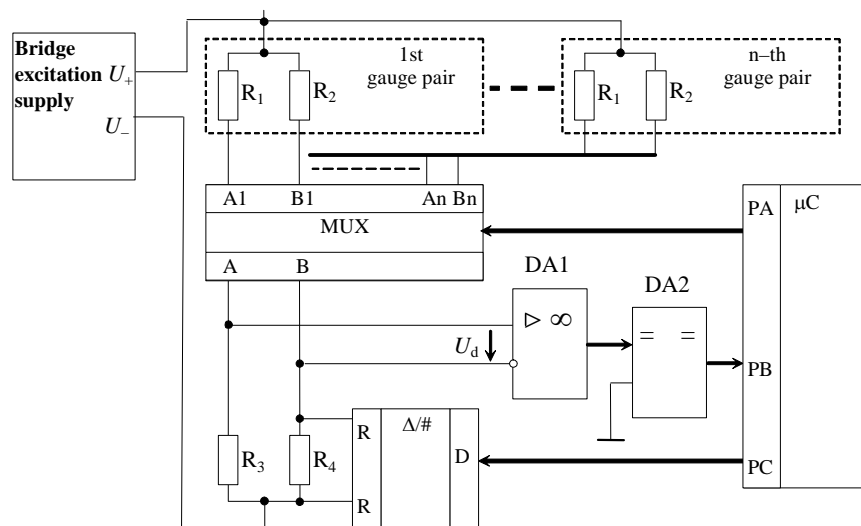

Fig. 2. Functional scheme of the method for evaluation of small resistance changes by using automatically digitally balanced Wheatstone bridge with R-2R DAC

Digitally Balanced Wheatstone Bridge for Strain Measurements

The method for measurement of small resistance changes by using automatically digitally balanced Wheatstone bridge has been developed by authors [3, 4]. Method is based on using of R-2R DAC as balancing element. General structure of the method is provided in Fig. 2. The resistance of the sensor in this case is:

$$R_x = R_1 = R_2 R_3 \frac{R_4 N + 2^n R_{IN}}{2^n R_4 R_{IN}}; \quad (3)$$

where n – number of DAC bits, R_{IN} – resistance of DAC input (resistance R-2R matrix elements), N – decimal DAC control code.

It is established that proposed method allows avoiding multiple disadvantages that are typical to the classic system. The created method is a feedback method. Wheatstone bridge is balanced by changing resistance of DAC and checking whether the balance is exceeded or not. As code controlled resistance DAC of R-2R type is used. MOSFET switches are used for connection and disconnection of different channels. These switches have resistance of the open channel less than 0.05 Ohm and therefore the influence of these resistors to the measurement result is minimal.

The main advantages of this method are:

- Feedback system is regulating itself and therefore reducing influence of external noise to evaluation results.
- System is not influenced by length and resistance of the gauge connecting wires and therefore can be easily used as multi-channel system by multiplexing gauges using low resistance switches.
- The strain measurement in the system is made in two stages: the status of the bridge after gluing gauges on a construction to be measured, and the load is not applied to the structure. Then the status of the loaded construction is measured. The size of strain is defined

as a difference of these two measures. Analysis and experimental research has shown that this method can be used for monitoring tasks with resolution up to 2^8 . The model of the system was checked during 24 hours and worked with 10 m length cables. The measurement errors are not established for all this period of time.

The research of constructions in laboratory conditions is more complex problem. For deeper understanding of processes in the loaded constructions, it is necessary to measure strains of smaller sizes.

Further increase of resolution (for example, for laboratory or very high accuracy measurements) is possible only by taking measures to reduce external influence to the measurement results. It is established that main causes for inaccuracies are:

1. Zero drift of the operational amplifier.
2. Higher resolution leads to lower balancing voltage which is influenced by noise and bridge balance point can not be established precisely.

Methods of reducing these influences are analyzed. It is shown [3] that the resolution can be increased applying these methods:

Zero drifts are reduced with:

- a) Operational amplifiers for alternating voltage: usage of alternating voltage power supply for Wheatstone bridge and amplifiers with signal modulation.
- b) Compensate drifts: usage of duplicate operational amplifier and known reference evaluation just before evaluation of gauges.

Noises with lagging phases are reduced by:

- a) Usage of digital filters;
- b) Usage of hardware filtering;
- c) Averaging of evaluation results.

It is established that applying these methods in parallel it is possible to gain resolutions up to 2^{14} and therefore gain 0.024 % – 0.006 % accuracy level of evaluation of small resistance changes.

Experimental investigation of automatically digitally balanced Wheatstone bridge confirmed theoretical

assumptions. Methods of reducing noise influence are developed and confirmed during experiment.

Conclusions

1. It is possible to avoid unexpected construction collapses if the constructions are constantly monitored and preventive actions are performed.

2. Most of construction monitoring systems is relying on measurement of strain of multiple points of constructions.

3. The system for automatic multi-channel strain measurement is proposed. The method for evaluation of small changes of resistance based on automatically digitally balanced using DAC R-2R matrix Wheatstone Resistance Bridge is developed and investigated.

4. The proposed method enables to improve evaluation of small changes of resistance and to avoid disadvantages observed in classic non-balanced Wheatstone bridge applications. The accuracy of the method is not influenced by the stability of the bridge excitation voltage and the feedback nature of the system reduces the influence of external interferences to evaluation result.

5. The developed multi-channel system is relatively low cost compared to classic system as it is not influenced by cable and switch parasite parameters.

6. The methods of improvement of evaluation quality and resolution are investigated. It is established that combining different methods it is possible to achieve 12 – 14 bits resolution (0.024 – 0.006) % accuracy). It is established that it is necessary to use digital signal processing and different compensation methods in combination for gaining such accuracy.

References

1. **The Pressure, Strain and Force Handbook.** – Omega Engineering. – 1995. – Vol. 29.– 1189 p.
2. **Doebelin E. O.** Measurement Systems Application and Design. – 4th Ed. McGraw-Hill, 1990. – 876 p.
3. **Kvedaras R., Kvedaras V., Martavičius R.** Elektroninė sistema unikalių konstrukcijų būsenos pokyčiams įvertinti // Elektronika ir elektrotechnika. – Kaunas: Technologija, 2003. – No. 6(48). – P. 28–32.
4. **Kvedaras R.** Fulfillment of general Requirements for Construction State Identification Systems // Conference Archives PTETiS.– 2004. – Vol. 19, No. 1. – P. 60–63.

Submitted for publication 2007 10 15

R. Kvedaras, V. Kvedaras. Strain Measurements and Monitoring of Constructions // Electronics and Electrical Engineering. – Kaunas: Technologija, 2008. – No. 1(81). – P. 65–68.

Results of analysis of recent accidents in public buildings are presented. It is shown that construction state identification systems are integral part of public and local warning and security systems. This system is highly flexible and can cover system of a separate structure, and also can be expanded to group of structures (houses, bridges, etc.) or to systems of identification of the whole city. Structure of construction state identification system is proposed and analysed. It is established that in order to ensure wide usage of such systems it is necessary to solve some scientific problems. Solution for multipoint measurement of strain as one of the most important parameter for construction state identification is proposed. It is shown that measurements of strain by using closed-loop self-balancing system ensure necessary resolution with high accuracy and can be used in multipoint measurements. It is possible to increase amount of points of measurement by easily adding additional measuring blocks. These blocks are well integrated into the suggested system of identification. Ill. 2, bibl. 4 (in English; summaries in English, Russian and Lithuanian).

P. Квядарас, В. Квядарас. Измерения деформаций и мониторинг конструкций // Электроника и электротехника. – Каунас: Технология, 2008. – No. 1(81). – С. 65–68.

Представлены результаты анализа недавних несчастных случаев в общественных зданиях. Показано, что системы идентификации состояния конструкции – неотъемлемая часть общего и местного предупреждения и систем безопасности. Предложена и проанализирована структура системы идентификации состояния конструкции. Данная система является очень гибкой и может охватывать систему отдельного строения, а также может быть расширена до группы строений (домов, мостов и т.п.) или системы идентификации строений целого города. Установлено, что для широкого использования таких систем необходимо решить некоторые научные проблемы. Предложено решение многоточечного измерения деформации как одного из самых важных параметров для идентификации состояния конструкции. Показано, что измерения деформации, используя систему самобалансирования закрытой петли гарантируют необходимое решение с высокой точностью и могут использоваться в многоточечных измерениях. Увеличить количество точек измерения легко можно увеличив добавляя дополнительные измерительные блоки. Эти блоки хорошо интегрируются в предложенной системой идентификации. Ил. 2, библи. 4 (на английском языке; рефераты на английском, русском и литовском яз.).

R. Kvedaras, V. Kvedaras. Deformacijų matavimas ir konstrukcijų monitoringas // Elektronika ir elektrotechnika. – Kaunas: Technologija, 2008. – Nr. 1(81). – P. 65–68.

Pristatoma neseniai visuomeniniuose pastatuose įvykusių avarių analizė. Parodyta, kad konstrukcijų būsenos identifikavimo sistemos yra būtina ir neatskiriama bendrųjų ir vietinių saugos sistemų dalis. Pasiūlyta ir išanalizuota konstrukcijų būsenų identifikavimo sistemos struktūra. Ši sistema yra ypač lanksti ir gali apimti atskiro statinio sistemą, taip pat gali būti išplėsta iki statinių (pastatų, tiltų ir pan.) grupės ar viso miesto statinių konstrukcijų būsenų identifikavimo sistemos. Parodyta, kad norint plačiai taikyti tokias sistemas, reikia išspręsti tam tikras mokslines problemas. Pasiūlytas daugiataškis deformacijų, kaip vieno iš svarbiausių konstrukcijų būsenų identifikavimo parametru, matavimo būdas. Parodyta, kad deformacijų matavimas, naudojant uždaros kilpos susibalansuojančią sistemą, garantuoja reikalingą sprendimą su dideliu tikslumu ir gali būti naudojamas daugiataškiuose matavimuose. Matavimo blokų didinimas leidžia nesudėtingai plėsti matavimo taškų skaičių ir integruoti šiuos modulius į pasiūlytą sistemą. Il. 2, bibl. 4 (anglų kalba; santraukos anglų, rusų ir lietuvių k.).

