

## Modeling and Investigation of Vector Controlled Induction Drive

**R. Rinkevičienė, V. Batkauskas**

*Department of Automation, Vilnius Gediminas Technical University,  
 Naugarduko str. 41, LT-03227 Vilnius, Lithuania, phone: +370 274 47 54; e-mail: asm@el.vtu.lt*

### Introduction

The cage induction motor is the most popular machine for industrial applications. It is also the most complex from the viewpoint of drive control. Computer simulation is widely applied in various system studies. For developments of the power electronic and control system simulation provides numerous advantages such as concept proof of the circuit topology, development of the control algorithm, study of efficiency and performance. These computer based simulation techniques save costs before developing the unit. Vector (or “field-oriented”) control algorithms are widely used in high-performance drives, providing precise and responsive speed control, and guaranteeing optimized efficiency during transient operations [1, 2]. In industrial applications, vector drives are often required to operate from zero speed (including zero speed start-up). Therefore we propose a model of the AC motor drive based on the low-speed region where rotor flux components can be synthesized more easily with the help of speed and current signals.

### Development of model of induction motor

Dynamic performance of an AC machine is complex problem taking into account three phase rotor windings moving with respect to three-phase stator windings. The coupling coefficient changes continuously with the change of rotor position  $\theta_r$  and machine model is described by differential equations with time varying mutual inductances. To simplify the problem solution, any three phase induction machine can be represented by an equivalent two phase machine, where  $d_s - q_s$  are stator direct and quadrature axes as well as  $d^r - q^r$  are rotor direct and quadrature axes. The problem becomes simple, but problem of time varying parameters still remains. Park transformation refers the stator variables to a synchronous reference frame, fixed on the rotor. It results to all time varying inductances being eliminated. The other kind of transformation widely used is G. Kron transformation, relating both stator and rotor variables to a synchronously rotating reference frame that moves with the rotating magnetic field. Time-varying inductances in the voltage

equations of an induction machine also can be eliminated by transforming rotor variables to variables associated with fictitious stationary windings. In this case, the rotor variables are transformed to a stationary reference frame fixed on the stator. This method was proposed by H. S. Stanley [1]. The paper presents a mathematical model of the induction motor in a stationary reference frame. A mathematical model of the linear induction motor in stationary reference frame  $\alpha, \beta$  developed for the linear motor is presented in [3]. For revolving induction motor it can be written in terms of variables along quadrature and direct axes as:

$$\begin{cases} u_{ds}^s = \left[ \left( \frac{1}{L_s} + \frac{L_m k_1}{L_s L_r} \right) \cdot \psi_{ds}^s - \frac{L_m}{L_s L_r} \cdot \psi_{ds}^r \right] \cdot R_s + \frac{d\psi_{ds}^s}{dt}; \\ u_{qs}^s = \left[ \left( \frac{1}{L_s} + \frac{L_m k_1}{L_s L_r} \right) \cdot \psi_{qs}^s - \frac{L_m}{L_s L_r} \cdot \psi_{qs}^r \right] \cdot R_s + \frac{d\psi_{qs}^s}{dt}; \\ u_{ds}^r = \left[ \frac{1}{L_r} (\psi_{ds}^r - k_1 \cdot \psi_{ds}^s) \right] \cdot R_r + \frac{d\psi_{ds}^r}{dt} + \omega_r \cdot \psi_{qs}^r; \\ u_{qs}^r = \left[ \frac{1}{L_r} (\psi_{qs}^r - k_1 \cdot \psi_{qs}^s) \right] \cdot R_r + \frac{d\psi_{qs}^r}{dt} + \omega_r \cdot \psi_{ds}^r, \end{cases} \quad (1)$$

where  $\psi_{ds}^s, \psi_{ds}^r$  – stator flux linkages aligned with the direct axis;  $\psi_{qs}^s, \psi_{qs}^r$  – stator flux linkages aligned with quadrature axis;  $R_s$  – stator phase resistance,  $R_r$  – rotor phase resistance, referred to stator;  $u_{ds}^s, u_{qs}^s, u_{ds}^r, u_{qs}^r$  – stator and rotor voltages. In the stationary reference frame  $u_{ds}^s = U_{1\max} \cos \omega_0 t$ ,  $u_{qs}^s = U_{1\max} \sin \omega_0 t$  where  $U_{1\max}$  is amplitude of voltage and  $\omega_0 = 2\pi f$  is angular frequency.  $L_m$  is magnetizing inductance,  $L_s = L_{1s} + L_m$  is stator inductance,  $L_{1s}$  is stator leakage inductance;  $L_r = L_{1r} + L_m$ ,  $L_{1r}$  is rotor leakage inductance referred to stator and  $k_1 = L_m / L_s$ .

Torque, delivered by motor, is calculated as:

$$T = \frac{\pi p}{L_s L_r - L_m^2} (\psi_{qs}^s \cdot \psi_{ds}^r - \psi_{qs}^r \cdot \psi_{ds}^s), \quad (2)$$

where  $p$  is number of pole pairs.

The Simulink model of the induction motor is presented in Fig. 1.

The model has been realized using the actual parameters of the induction motor presented in the Table 1.

Table 1. Parameters of the induction motor

Parameter	U	P	n	R <sub>S</sub>	L <sub>S</sub>	R <sub>R</sub>	L <sub>R</sub>
Units	[V]	[kW]	[rpm]	[Ω]	[mH]	[Ω]	[mH]
Value	220	1,1	1415	5,12	4,79	1,43	4,96

The developed model of the induction motor can be used with various motor parameters in order to analyze different transients in the motor with desired load on the shaft.

### The vector control model with the torque-generated stator current component

The vector control method of the induction motor drive is presented in Fig. 2. [4]. The inverter is simplified and shown without the power conversion control circuit. Stator currents and motor shaft speed are used in the vector control system. The speed control loop generates the torque component of current  $i_{qs}^*$ ; the flux component of current  $i_{ds}^*$  for desired rotor flux  $|\psi_r|^*$  is maintained constant for simplicity. If the rotor flux is constant in indirect vector control, which is usually the case, then it is directly proportional to steady state current  $i_{ds}$ .

Magnitude of the estimated rotor flux linkage is calculated as:

$$|\psi_r| = \frac{L_m \cdot i_{ds}}{1 + \tau_r s}, \quad (3)$$

where  $\tau_r$  is time constant of the rotor electrical circuit.

The direct component of current is found as:

$$i_{ds}^* = \frac{|\psi_r|^*}{L_m}. \quad (4)$$

The quadrature component of stator current is:

$$i_{qs}^* = \frac{2}{3} \cdot \frac{2}{p} \cdot \frac{L_r}{L_m} \cdot \frac{T_e^*}{|\psi_r|^*}, \quad (5)$$

where  $T_e^*$  is electromagnetic torque.

The angle between the d<sup>s</sup> and d<sup>e</sup> axes, correspondingly in stationary and synchronous reference frames is calculated as [1]:

$$\theta_e = \int (\omega_r + \omega_{sl}) dt, \quad (6)$$

where  $\omega_r$  is rotor speed,  $\omega_{sl}$  is slip frequency.

Slip frequency is found from the stator current component  $i_{qs}^*$  and other motor parameters:

$$\omega_{sl} = \frac{L_m}{|\psi_r|^*} \cdot \frac{R_r}{L_r} \cdot i_{qs}^*. \quad (7)$$

According to the model, presented in Fig. 1 and equations (3, 4, 5, 6 and 7) the computer model of the vector-controlled drive, presented in Fig. 2, is developed.

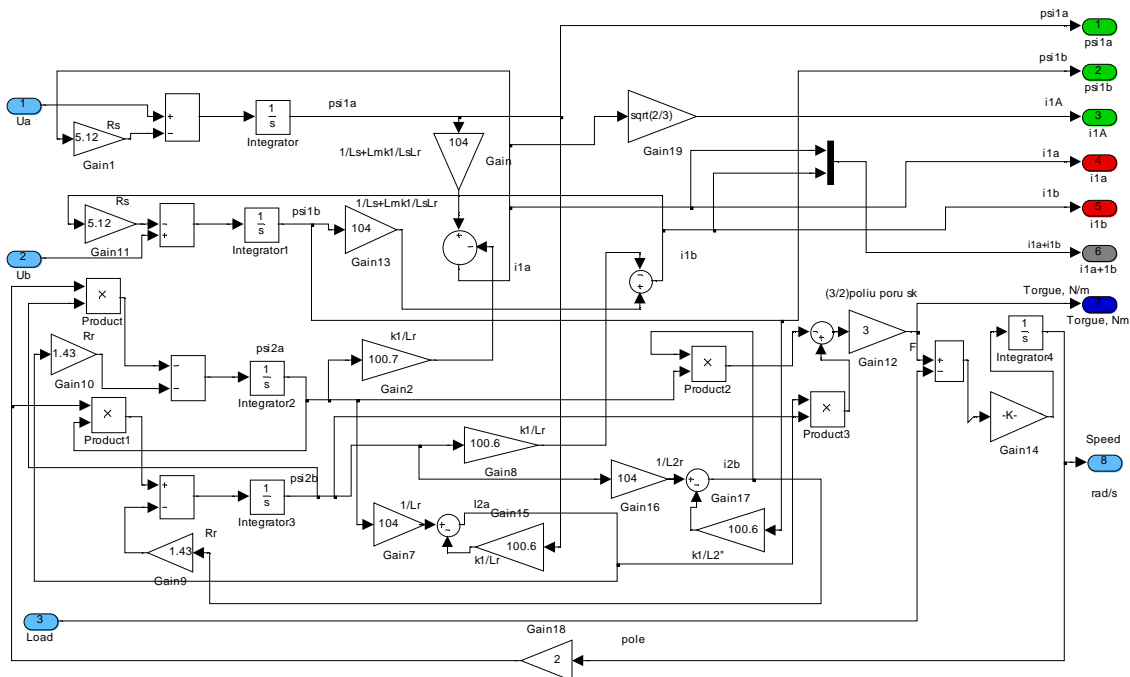
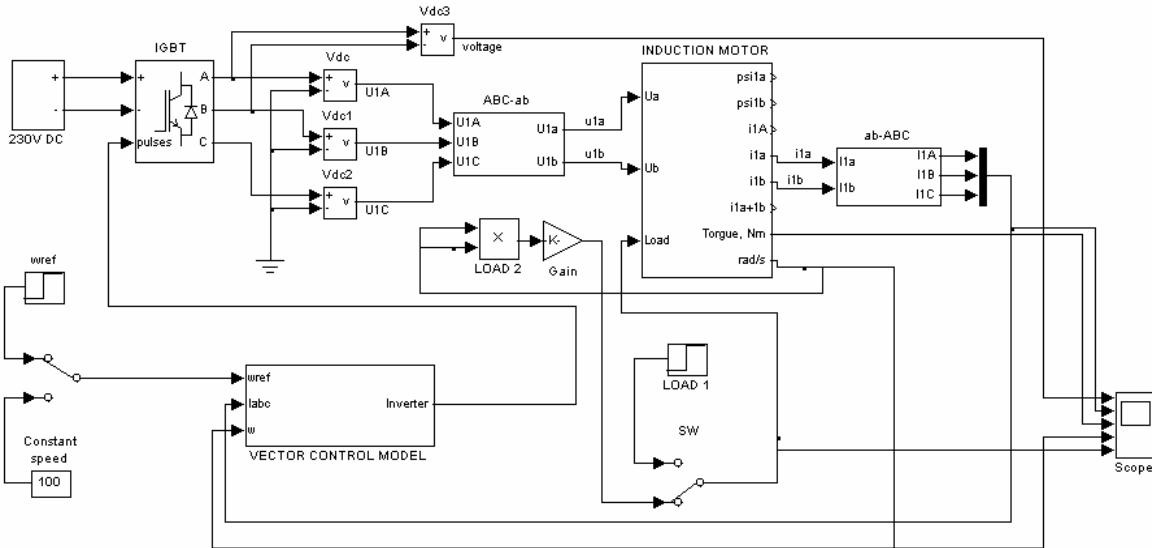


Fig. 1. The induction motor model in d<sup>s</sup> - q<sup>s</sup> stationary reference frame



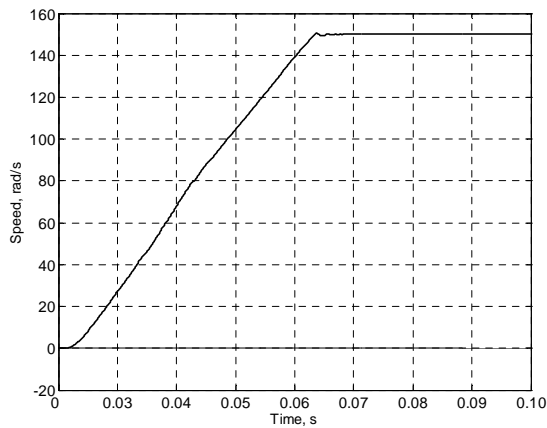
**Fig. 2.** The Simulink model for the inverter controlled induction motor drive

For comparison of simulation results, scalar control and vector control of induction motor Simulink models has been elaborated. Simulation of scalar or V/Hz control has been made with the same induction motor model shown in Fig. 1 without the speed feedback. Also a part of the Simulink model devoted for vector control, shown in Fig. 2, is replaced with the standard PWM (Pulse Width Modulation) function block adjusted to three-phase PWM control [5, 6].

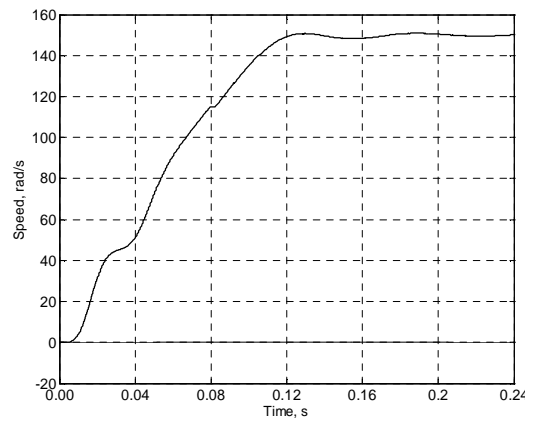
The Simulink model of vector control induction motor drive consists of models for power supply, PWM inverter, induction motor drive in the stationary reference frame and vector controlled algorithm.

### Simulation results of induction motor drive

For comparison simulations are made with two different motor control methods. Fig. 3, and Fig. 4, present the dynamic motor transients of rotor speed simulated with indirect vector control and with the scalar (V/Hz) control method respectively. Rotor speed increases from 0 to 150 rpm in both control methods.

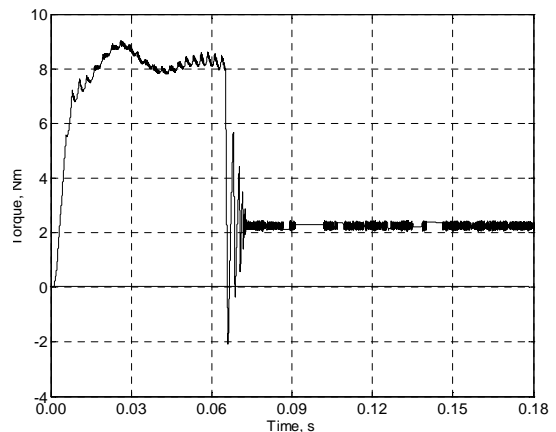


**Fig. 3.** Starting transients of speed at the vector control model

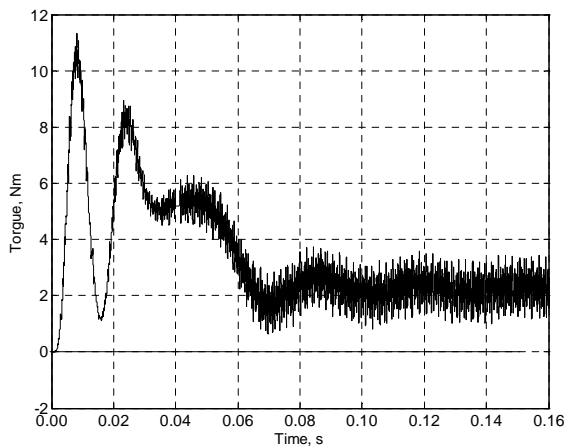


**Fig. 4.** Starting transients of speed at the scalar control model

From Fig. 3 we can observe speed response with constant acceleration and steady state speed value is achieved in 0.065 sec. With the scalar control method without the speed feedback steady state speed is achieved only in 0.12 sec. Respectively torque transient characteristics of different motor control methods can be analyzed in figures 5 and 6.



**Fig. 5.** Dynamic torque characteristic with the vector control model



**Fig. 6.** Dynamic torque characteristic with the scalar (V/Hz) drive control method

### Conclusions

1. The developed simulation model for vector control with stator flux orientation can be used for high importance in high-performance drive applications.
2. A mathematical model of induction motor in stationary reference frame is developed.
3. Speed response time of the motor with vector control is two times shorter than the same motor speed transient with the scalar control method.
4. In the scalar control method maximum dynamic torque value is 60% higher than nominal motor torque value, while in the vector control method the motor accelerates with constant, approximately 20% higher torque than a

nominal motor torque value. That results in transients of drive speed at constant acceleration for the vector control.

### Acknowledgement

This work was supported by the Lithuanian State Science and Studies Foundation under High-tech development program project B –13/2007.

### References

1. **Bimal K. Bose.** Modern Power Electronics and AC Drives. – New Jersey: Prentice Hall PTR, 2002. – 738 p.
2. **Jih-Shen Lai and Bimal K. Bose.** A PC-based simulation and DSP-based control of an improved high frequency resonant DC link inverter induction motor drive // IEEE Conf. – March, 1990. – P. 882–888.
3. **Rinkevičienė R., Lisauskas S.** Models of mechatronic systems with linear motors // Electronics and electrical engineering. – Kaunas: Technologija, 2003. – No. 4(46). – P. 69–73. In Lithuanian.
4. **Vas P.** Electrical Machines and drives. – Oxford University Press, 1999. – P. 768.
5. **Rafajlovski G., Ratz E., Manov D.** Modeling Analysis and Simulation of Motor Parameter Variation in Vector Controlled Electrical Drives // Department of electrical machines, Electrotechnical Faculty. – 1997. – P. 837–841.
6. **Yen-Shin Lai.** Machine Modeling and Universal Controller for Vector-Controlled Induction Motor Drives // IEEE transactions on energy conversion. – 2003. – Vol. 18, No. 1. – P. 23–32.

Submitted for publication 2007 10 15

### **R. Rinkevičienė, V. Batkauskas. Modeling and Investigation of Vector Controlled Induction Drive // Electronics and Electrical Engineering. – Kaunas: Technologija, 2008. – No. 1(81). – P. 53–56.**

Modeling and simulation of the AC induction motor drive controlled by the vector or field-oriented method and comparison results with scalar control is discussed. Motor speed is controlled by a torque-generated stator current component while maintaining the flux-generated current component steady. The torque-generated current component is corrected to track its set point in the current controller using its own dedicated PI controller. Set of differential equations of the induction motor for development of the model is derived. The motor model is developed in a stationary reference frame. Simulation results of two models, one with vector control and other with scalar control, are presented and analyzed. Ill. 6, bibl. 6 (in English; summaries in English, Russian and Lithuanian).

### **Р. Ринкявичене, В. Баткаускас. Моделирование и исследование асинхронного привода с векторным управлением // Электроника и электротехника. – Каunas: Технология, 2008. – № 1(81). – С. 53–56.**

Рассматривается разработка моделей и результаты моделирования асинхронного электропривода с векторным управлением, а также сравнение результатов скалярного и векторного управления. Скорость двигателя управляется составляющей тока статора, пропорциональной моменту двигателя, а составляющая тока, пропорциональная потоку, поддерживается постоянной. ПИ регулятор тока использован для поддержания и слежения заданной величины этой составляющей тока. Выведена система дифференциальных уравнений асинхронного двигателя в стационарной системе координат, на основе которой разработана модель асинхронного двигателя. Приводится сравнение результатов моделирования двух моделей: векторного и скалярного управления. Ил. 6, библи. 6 (на английском языке; рефераты на английском, русском и литовском яз.).

### **R. Rinkevičienė, V. Batkauskas. Vektorinio valdymo asinchroninės pavaros modeliavimas ir tyrimas // Elektronika ir elektrotechnika. – Kaunas: Technologija, 2008. – Nr. 1(81). – P. 53–56.**

Pateikti vektoriniu būdu valdomo asinchroninio variklio modeliavimo rezultatai. Jie lyginami su skaliariškai valdomo asinchroninio variklio modeliavimo rezultatais. Pavaros greitis reguliuojamas statoriaus srovės dedamąja, proporcinga sukimo momentui, palaikant srauto srovės dedamąją pastovią. Nustatytoji srovės dedamosios, proporcingos momentui, vertė palaikoma naudojant PI valdiklį. Išvesta asinchroninio variklio diferencialinių lygčių sistema, kuria remiantis sudarytas variklio modelis Simuliuok programoje. Variklio modelis sudarytas nejudamoje koordinačių sistemoje. Pateikiami dviejų tipų pavarų modelių imitavimo rezultatai; palygintas skaliarinis ir vektorinis pavaros valdymas. Il. 6, bibl. 6 (anglų kalba; santraukos lietuvių, anglų ir rusų k.).

DOI: 10.5755/j02.eie.11034