

Instability of Structure Plates under Two-directional Compression

A. Žiliukas

*Department of Mechanics of Solids, Kaunas University of Technology,
 Kestucio str. 27, Kaunas LT-44025, Lithuania, phone: +370 37 300431, e-mail: antanas.ziliukas@ktu.lt*

Introduction

For the perfect structures the peculiarities of deformability, strength and stability of plate form elements are very essential due to the security of accurate and reliability of performed functions. The instability of structure plate studies were published by various authors [1-10]. The most of them is based on classical Kirchoff hypothesis of thin plates. According to this theory, the instability is calculating from the equilibrium equations. However, in these studies, the poor attention is paid to the behaviour of materials in the case of complex loading. In these studies, the influence of both normal and shear stress acting in the same time is not evaluated. Whereas, it is very important for the investigation of elastic-plastic materials.

In this study according to classical solutions in both the case of unidirectional and two-directional loading in the analogical way as in the case of strength criteria, the stability criterion is suggested. The influence of geometry is modelled in this study. This allows the covering all of the complex loading cases and the evaluating of the behaviour of the elastic-plastic materials. The analytical results are compared to experimental ones.

Instability of Plates

The equation governing buckling of plates under inplane compressive and shear forces is [11]

$$\frac{\partial^2 M_{xx}}{\partial x^2} + 2 \frac{\partial^2 M_{xy}}{\partial y \partial x} + \frac{\partial^2 M_{yy}}{\partial y^2} = \frac{\partial}{\partial x} \left(\bar{N}_{xx} \frac{\partial w}{\partial x} + \bar{N}_{xy} \frac{\partial w}{\partial y} \right) + \frac{\partial}{\partial y} \left(\bar{N}_{xy} \frac{\partial w}{\partial x} + \bar{N}_{yy} \frac{\partial w}{\partial y} \right), \quad (1)$$

where M_{xx} , M_{yy} are the bending moments per unit length; M_{xy} are the twisting moment per unit length, and \bar{N}_{xx} , \bar{N}_{yy} , \bar{N}_{xy} are the applied inplane compressive and shear forces measured per unit length; w is the deflection; x , y are plate coordinates (Fig. 1).

For homogeneous plates, the equation of equilibrium (1) takes the form

$$D_{11} \frac{\partial^4 w}{\partial x^4} + 2(D_{12} + 2D_{66}) \frac{\partial^4 w}{\partial y^2 \partial x^2} + D_{22} \frac{\partial^4 w}{\partial y^4} + \frac{\partial}{\partial x} \left(\bar{N}_{xx} \frac{\partial w}{\partial x} + \bar{N}_{xy} \frac{\partial w}{\partial y} \right) + \frac{\partial}{\partial y} \left(\bar{N}_{xy} \frac{\partial w}{\partial x} + \bar{N}_{yy} \frac{\partial w}{\partial y} \right) = 0, \quad (2)$$

where $D_{11} = \frac{E_1 h^3}{12(1-\nu_{12}\nu_{21})}$, $D_{12} = \nu_{21} D_{11}$, $D_{22} = \frac{E_2}{E_1} D_{11}$, $D_{66} = \frac{G_{12} h^3}{12}$, E_1 , E_2 are elasticity modulus, G_{12} is shear modulus, ν_{12} , ν_{21} are Poisson ratios, h is thickness of plates.

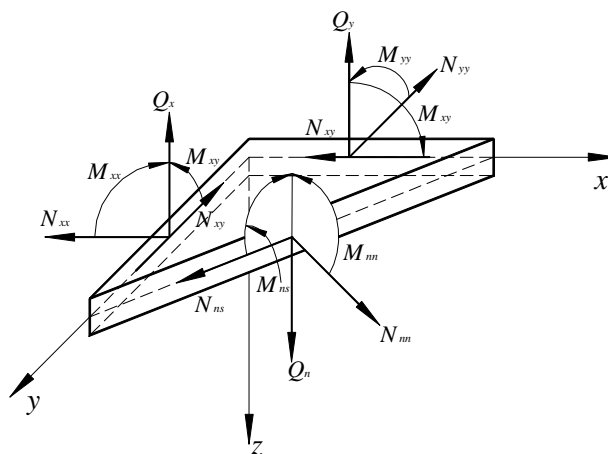

Fig. 1. Applied inplane forces and moments in plate element

According to these solutions, the rectangular plate was investigated [11]. The equation governing buckling deflection w a biaxially loaded plate (Fig. 2) is given by

$$D_{11} \frac{\partial^4 w}{\partial x^4} + 2\bar{D}_{12} \frac{\partial^4 w}{\partial y^2 \partial x^2} + D_{22} \frac{\partial^4 w}{\partial y^4} + \bar{N}_{xx} \frac{\partial^2 w}{\partial x^2} + \bar{N}_{yy} \frac{\partial^2 w}{\partial y^2} = 0, \quad (3)$$

where $\bar{D}_{12} = D_{12} + 2D_{66}$, $\bar{N}_{xx} = N_0$, $\bar{N}_{yy} = \gamma N_0$.

$$\gamma = \frac{\bar{N}_{yy}}{N_{xx}}. \quad (4)$$

For simply supported biaxially loaded plates the exact buckling load [11] can be expressed as

$$N_0(m, n) = \frac{\pi^2}{b^2} \cdot \frac{D_{11}s^4m^4 + 2\bar{D}_{12}s^2m^2n^2 + D_{22}n^4}{s^2m^2 + \gamma n^2}, \quad (5)$$

where $s = b/a$ is the plate aspect ratio. Thus, for each choice of m and n there is a unique value of N_0 . The critical buckling load is the smallest of $N_0(m, n)$. For the given rectangular plate, this value is dictated by a particular combination of values of m and n , value of γ , plate dimensions and material properties.

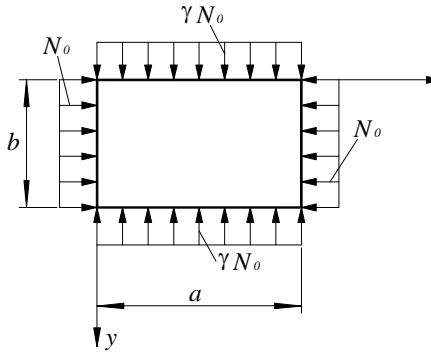

Fig 2. Biaxial compression of rectangular plate

For a square orthotropic plate with $\gamma = 1$

$$N_0(m, n) = \frac{\pi^2}{a^2} \cdot \frac{m^4 D_{11} + 2m^2 n^2 \bar{D}_{12} + n^4 D_{22}}{m^2 + n^2}. \quad (6)$$

For a square isotropic plate ($D_{11} = D_{22} = D$, $D_{12} = \nu D$, $2D_{66} = (1-\nu)D$ or $\bar{D}_{12} = D$) and $m = n = 1, \gamma = 1$

$$N_0(1,1) = N_{cr} = \frac{2\pi^2 D}{a^2} \left(\frac{N}{m} \right). \quad (7)$$

From eq. (7) follows

$$\sigma_{cr} = \frac{2\pi^2 E t^3}{12(1-\nu^2)a^2} \cdot \frac{1}{t} = \frac{\pi^2 E}{6(1-\nu^2)} \cdot \left(\frac{t}{a} \right)^2 \left(\frac{N}{m^2} \right). \quad (8)$$

In the case of uniaxial compression as $\gamma = 0$ follows [11]

$$\sigma_{cr} = \frac{4\pi^2 D}{a^2 t} = \frac{\pi^2 E}{3(1-\nu^2)} \cdot \left(\frac{t}{a} \right)^2. \quad (9)$$

In the other loading cases, the solutions are difficult as parameters m and n are unknown. Due to this, the more practical methods of critical instability stress evaluation are needed.

Determination of Plate Instability According to Limit Stress State

Accepted that the instability occurrence depends on both the normal compression stress and shear stress, the

instability condition can be expressed in the same way as the yielding one. In this case, not only the materials properties influence the stability losing but also the plate geometry and this must be evaluated.

According to this the instability condition can be written as follows [12, 13]

$$\sigma_{ekv} = m_1 |\sigma_{i,c}| + m_2 |\sigma_{0,c}| = |\sigma_{cr}|, \quad (10)$$

where σ_{ekv} is the equivalent stress, $|\sigma_{i,c}|$ is the critical stress intensity, $|\sigma_{0,c}|$ is the critical average stress, m_1 and m_2 are the parameters influenced buckling which depend on material, structure geometry and constrain, $|\sigma_{cr}|$ is the critical instability stress.

As the parameters m_1 and m_2 are determined, the critical instability stress $|\sigma_{cr}|$ can be calculated in all loading cases.

Determination of the Critical Instability Stress According to Materials Properties

The rectangular plate of thickness $t = 0.7$ mm, and length $a = 70$ mm was made of steel with mechanical properties $E = 2 \cdot 10^5$ MPa, $\nu = 0.3$, and yielding compression stress $|\sigma_{y,c}| = 253$ MPa.

According to eq. (10) the following can be written

a) biaxial compression as $|\sigma_{3,c}^*| = |\sigma_{2,c}^*|$

$$m_1 |\sigma_{3,c}^*| + m_2 \frac{2}{3} |\sigma_{3,c}^*| = |\sigma_{cr}|; \quad (11)$$

b) uniaxial compression as $|\sigma_{3,c}| = |\sigma_{cr}|$

$$m_1 + \frac{1}{3} m_2 = 1. \quad (12)$$

Then

$$m_1 = \frac{|\sigma_{cr}| - |\sigma_{3,c}^*|}{|\sigma_{3,c}^*|}, \quad (13)$$

$$m_2 = \frac{3(|\sigma_{cr}| - |\sigma_{3,c}^*|)}{|\sigma_{3,c}^*|}. \quad (14)$$

From eq. (9) in the case of uniaxial compression $|\sigma_{cr}| = 144$ MPa, from eq. (8) in the case of biaxial compression $|\sigma_{3,c}^*| = 72$ MPa.

From eq. (13) and (14) $m_1 = 0.5$ and $m_2 = 1.5$.

According to this, the instability of plate of dimensions $0.7 \times 70 \times 70$ mm can be determined by eq. (10) as the loading varied according to ratio $\gamma = \frac{|\sigma_2|}{|\sigma_3|}$.

Experimental

For the experimental investigation of critical instability stress the above mentioned plate of dimensions $0.7 \times 70 \times 70$ mm was chosen and it was loaded until instability occurs

by stress value according to the ratio $\gamma = \frac{|\sigma_2|}{|\sigma_3|}$. The tests

were run on testing machine VEB EU-20. The additional equipment was used for biaxial loading; it is shown in Fig. 3.

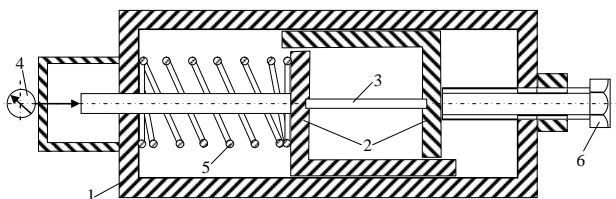

Fig. 3. The additional equipment for biaxial loading; 1 – dismantlable body, 2 – plate clamp, 3 – plate, 4 – dynamometer, 5 – spring, 6 – screw

During experimental compression testing five values of $|\sigma_{2,c}|$ were chosen and the values of $|\sigma_{3,c}|$ were cared out. The experimental results are presented in Table 1.

Table 1. Experimental results

No	$ \sigma_{2,c} $, MPa	$ \sigma_{3,c} $, MPa	$ \sigma_{3,c} $		
			Coefficient of variation, v	Relative deviation, s	Relative standard deviation, \bar{s}
1	0	140	1.07	4.20	1.50
2	20	132	1.20	4.50	1.60
3	30	127	1.35	4.72	1.68
4	40	124	1.37	4.80	1.70
5	50	117	1.54	5.10	1.80

According to the results presented in Table 1, $|\sigma_{ekv}|$ was calculated and compared to $|\sigma_{cr}|$ obtained from eq. (9). Stress results are shown in Table 2.

Table 2. Values of limit instability stress

No	$ \sigma_{2,c} $, MPa	$ \sigma_{3,c} $, MPa	$ \sigma_{cr} $, MPa eq. (9)	$ \sigma_{ekv} $, MPa eq. (10)	Relative error,
					$\frac{ \sigma_{ekv} - \sigma_{cr} }{ \sigma_{cr} } \cdot 100\%$
1	0	140	144	140.0	-2.70
2	20	132		137.4	-4.58
3	30	127		140.0	-2.70
4	40	124		136.5	-5.20
5	50	117		134.2	-6.80

The results of experimental test show that experimental values of critical instability stress are lower than calculate ones. That can be explained by this. The experiment can not be carried out completely exact compare to perfect loading conditions accepted in theoretical calculations. However, the verifiable of the criteria written as eq. (10) shows that the relative error not exceeds limit of 7%. This value of error is accepted, as the spread of stability parameters is high.

Conclusions

1. The evaluation of critical instability compression stress of the plate loaded by complex loading by the classical methods is complicated and heavily prognosticated if plate deformability parameters are unknown. The classical solutions analyse only separate cases of deformation.

2. According to the strength and instability criteria analogy it is enough to analyse limit states or loss of stability in separate cases and obtain the universal solution. This is shown by obtained in this study relationship of critical stress intension with respect to the average stress, that is called as instability condition and expressed as eq. (10)

3. The experimental researches, as the chosen plates were used, showed the acceptability of suggested method.

4. The suggested method can be used as the critical instability stress is evaluated for the plates of particular dimensions in the cases of uniaxial and biaxial compression; the more complex loading cases can be evaluated according to the universal criterion expressed as eq. (10).

References

1. **Timoshenko, S. P., and Gere J. M.** Theory of Elastic Stability. – McGraw–Hill, New York. – 1961. – 541 p.
2. **Timoshenko, S. P., and Woinowsky – Krieger S.** Theory of Plates and Shells. – McGraw–Hill, Singapore. – 1970. – 386 p.
3. **Bulson P. L.** The Stability of Flat Plates. – Chotto and Windus. – London, United Kingdom. – 1970. – 414 p.
4. **McFarland, D., Smith, B. L., and Bernhart N. D.** Analysis of Plates. – Spartan Books, Philadelphia, PA. – 1972. – 323 p.
5. **Szillard R.** Theory of Analysis of Plates. Classical and Numerical Methods. – Prentice–Hall, Englewood Cliffs, NJ. – 1974. – 374 p.
6. **Panc V.** Theories of Elastic Plates. – Noordhaft, Leyden, The Netherlands. – 1975. – 424 p.
7. **Ugural A. C.** Stresses in Plates and Shells. – McGraw–Hill, New York. – 1981. – 457 p.
8. **Reddy J. N.** Theory and Analysis of Elastic Plates. – Taylor and Francis, Philadelphia, PA. – 1999. – 512 p.
9. **Reddy J. N.** Energy Principles and Variational Methods in Applied Mechanics. – 2nd ed., John Wiley, New York. – 2002. – 357 p.
10. **Reddy J. N.** Mechanics of Laminated Composite Plates and Shells: Theory and Analysis. – 2nd ed., CRC Press, Boca Ration, FL. – 2004. – 463 p.
11. **Wang C. M., Wang C. Y., Reddy J. N.** Exact Solutions for Buckling of Structural Members. – CRC Press, LLC. – 2005. – 285 p.
12. **Ziliukas A.** Strength and Fracture Criteria. – Kaunas: Technologija, 2006 (in Lithuanian). – 208 p.
13. **Ziliukas, A.** Fracture criterion developed for elastic-plastic Russian materials // Indian Journal of Engineering & Materials Sciences, ISSN 0971-4588. – New Delhi. – 2005. – Vol. 12, No. 5, P. 451–455.

Submitted for publication 2007 09 15

A. Žiliukas. Instability of Structure Plates under Two-directional Compression // Electronics and Electrical Engineering. – Kaunas: Technologija, 2008. – No. 1(81). – P. 7–10.

For the perfect structures the peculiarities of deformability, strength and stability of plate form elements are very essential due to the security of accurate and reliability of performed functions. According to the studies of other authors, the poor attention is paid to the behaviour of materials in the case of complex loading. In these studies, the influence of both normal and shear stress acting in the same time is not evaluated. Whereas, it is very important for the investigation of elastic-plastic materials. In this study according to classical solutions in both the case of unidirectional and two-directional loading in the analogical way as in the case of strength criteria, the stability criterion is suggested. The influence of geometry is modelled in this study. This allows the covering all of the complex loading cases and the evaluating of the behaviour of the elastic-plastic materials. The analytical results are compared to experimental ones. Il. 3, bibl. 13 (in English; summaries in English, Russian and Lithuanian).

А. Жилиюкас. Нестабильность конструкционных пластинок при двухосном сжатии // Электроника и электротехника. – Каунас: Технология, 2008. – № 1(81). – С. 7–10.

Надежность конструкционных пластин оценивается их деформативностью, прочностью и стабильностью. Как показывают работы других авторов, при анализе пластинок недостаточное внимание уделяется их механическим свойствам и работоспособности при сложных нагрузках. В статье представляются решения, посвященные определению стабильности пластин, изготовленных из упругопластических материалов, при двухосном сжатии. Использование критерия прочности и геометрических параметров пластин позволило получить универсальный критерий неустойчивости для двухосного сжатия упругопластически деформированных пластин. Ил. 3, библи. 13 (на английском языке; рефераты на английском, русском и литовском яз.).

A. Žiliukas. Konstrukcinių plokštelių nestabilumas, esant dviašiam gniuždynui // Elektronika ir elektrotechnika. – Kaunas: Technologija, 2008. – Nr. 1(81). – P. 7–10.

Konstrukcinių plokštelių patikimumą lemia jų deformatyvumas, stiprumas ir stabilumas. Kaip rodo kitų autorių darbai, nagrinėjant plokšteles, nepakankamai atsižvelgiama į jų medžiagų savybes bei darbą, veikiant sudėtingoms apkrovoms. Straipsnyje pateikiami sprendiniai, skirti pusiau trapių plastinių medžiagų plokštelių stabilumui skaičiuoti, esant dviašiam gniuždynui. Pritaikius medžiagų stiprumo kriterijų ir įvertinus plokštelių geometrinius matmenis, gautas universalus sudėtingai apkrautų plokštelių, pagamintų iš tampriai plastinių medžiagų, nestabilumo kriterijus. Il. 3, bibl. 13 (anglų kalba; santraukos anglų, rusų ir lietuvių k.).

DOI: 10.5755/j02.eie.11023