

## Connection of the RES-based Power Plants into the Electric Grid

**V. Kepalas, Č. Ramonas,**

*Department of Control Technology, Kaunas University of Technology,*

*Studentų str. 48, LT-51367 Kaunas, Lithuania, phone: +370 37 300274, e-mail: ceslovas.ramonas@ktu.lt, vytautas.kepalas@ktu.lt*

**V. Adomavičius**

*The Centre for Renewables Energy Technologies, Kaunas University of Technology,*

*Studentų str. 48-329, LT-51367 Kaunas, Lithuania, phone: +370 37 351181; e-mail: vytautas.adomavicius@ktu.lt*

### Introduction

Lately renewable energy sources (RES) have been used for the power generation more and more. Wind turbines (WT) and photovoltaic (PV) power generating systems are the fastest developing technologies of electricity production in the power engineering sector [1].

New innovative WT are under development. The maximum capacity of a single WT should grow from current 5-6 MW till 8-10 MW until the 2010. Besides that, under prognosis in 2040 the world will produce up to 22 % of its electricity from wind energy [2]. This trend is a clear sign, which shows a great development of power electronics sector in the future as well.

The main reasons of the rapid development of RES-based energy technologies are the skyrocketing oil and gas prices, unlimited pollution of environment, global warming and diminishing fossil fuels resources. Besides, there are many well-known and important benefits from the development of the renewable energy production technologies – decreasing dependence on import of the fossil fuels, upturn of the environmental situation, new jobs and other.

The most advanced wind turbines have electronic power conversion systems as well and this trend for WT is strengthening. The concepts appeared to install the electronic power conversion systems into small and micro hydro power plants too [3].

Therefore implementation of the electronic power conversion systems into the RES-based power plants and integration of these plants into the power system are important subjects for the researchers and specialists of electronics and power engineering. Innovation in this sphere is necessary in order to improve processes of supply of RES origin power into the power system and to improve quality of electricity parameters.

### Peculiarities of the RES-based power supply into electric grid

Power, generated from the RES just after the primary converter, often does not have stable and standard parameters suitable for power supply into electric grid [4]. Therefore, controlled power electronic converters and automatic connecting and disconnecting switches are used in order to ensure the possibility to supply the RES origin electricity into the electric grid.

Amount of power generated by the WT and voltage fluctuations in the electric grid strongly depends on fluctuations of wind velocity and on interaction of wind rotor blades with air. As experimental researches showed, fluctuations of wind cause voltage and power flickers, which have frequency 0.1 Hz. Interaction between the wind rotor's blades and air causes flickers having 1-2 Hz frequency [5, 6, 7]. More significant voltage and power flicker emissions can be generated during the connecting and disconnecting processes of WT at the strong and gusty wind. Therefore, number of switching operations is limited by the standards for wind turbines. Permitted number of switching operations depends not only on parameters of wind, but also on number of wind turbines at the site and type of energy conversion system used in the WT.

Flicker emissions caused by one WT due to switching operations can be calculated by using this equation:

$$P_{fl} = 8 \cdot N_{120}^{0.31} \cdot k_{\alpha}(\varphi_k) \cdot \frac{S_n}{S_k}, \quad (1)$$

where:  $P_{fl}$  - flicker emissions of long term period,

$N_{120}$  – number of switching operations within 120-minute period,

$k_{\alpha}(\varphi_k)$  – flicker step factor of the WT for given network impedance phase angle  $\varphi_k$  at the point of WT connection to the electric grid,

$S_n$  – rated power of the wind turbine's generator,

$S_k$  – short-circuit power at the WT’s connection point.

Factor  $k_{\alpha}(\varphi_k)$  can be calculated by using this formula

$$k_{\alpha}(\varphi_k) \leq \frac{P_{fl}}{16} \frac{S_k}{\sqrt[3]{S_{\Sigma} \cdot S_n^2}}, \quad (2)$$

where  $S_{\Sigma}$  – total power of all connected WT at the site.

If  $n$  WT are connected into electric grid, their flicker emissions  $P_{fl\Sigma}$  can be calculated in the following way:

$$P_{fl\Sigma} = \frac{S}{S_k} \sqrt[3]{\sum_{i=1}^n N_{120} \{k_{\alpha}(\varphi_k) \cdot S_{n-i}\}^3}, \quad (3)$$

where  $n$  is total number of wind turbines at the site.

Analysis of equations (1) – (3) shows the ways for the diminishing intensiveness of flicker emissions: one possibility is the reduction of wind turbines capacity, another – the use of power storing buffer chains. The first way is hardly appreciated due to many benefits received from the wind power; the second one is not satisfactory due to the economical reasons. There could be one more solution – to work out a system for wind turbine’s power conversion with smoothly going connecting and disconnecting processes.

### Schematic possibilities for improving parameters of power supplied into electric grid

According to various sources of information WT can be divided in two groups according their capacity: small-scale ( $P < 100 \text{ kW}$ ) and large-scale ( $P \geq 100 \text{ kW}$ ) [5]. Small-scale WT mostly are used for local power needs and their integration into electric grid has not significant impact to the grid’s electricity parameters. AC or DC generators used in the small-scale WT often have buffer chains, therefore, their connection into electric grid does not give appreciable flicker emissions but unnecessary harmonic distortion may occur.

Double-fed asynchronous generators currently are often used in powerful wind turbines. These generators usually are connected with rotor of the WT by means of adjusting gear boxes. Mostly pitch control is used for the regulation of the generator’s rotational speed. Power electronics converters and necessary switches are used for the connection of generators to electric grid as it is described in many sources of reference, including [5, 8].

There are many different schemes for the integration of WTs into electric grid of power system. As a rule, more powerful WTs have more complex schemes for connection them into electric grid. Inverters synchronized with electric grid and controlled rectifiers are the main units of wind power conversion system. Apart from the power conversion units, the additional energy storage chains of short operational time are used too. WTs of small capacity (from 100 to 500 kW) have less complex converters.

The simple electrical schematic for the integration of WT with double-fed asynchronous generator into electric grid is shown in Fig. 1.

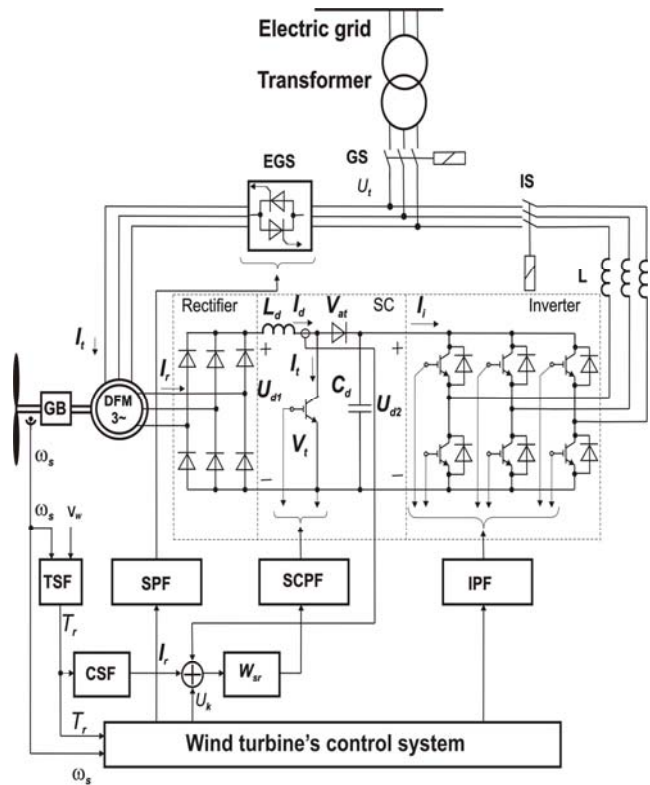

Fig. 1. Energy conversion electrical scheme for integration of WT into electric grid

As it is shown in Fig. 1, generator  $DFM$  of WT is connected to the electric grid by means of two electronic converters. Stator’s circuit is connected through electronic generator’s switch  $EGS$  and rotor’s circuit – through rectifier, short-circuiter, inverter and inverter’s switch  $IS$ . Short-circuiter has shunting transistor  $V_t$  and power storing elements  $L_d$  and  $C_d$ .

Wind turbine’s control system, depending on hub’s rotational speed  $\omega_s$ , changes the angle of inversion (by inverter’s pulse former  $IPF$ ) and width of shunting pulse (by shorting circuit pulse former  $SCPF$ ) and, therefore, simultaneously changes quantity of energy stored in choke  $L_d$ . Active and reactive energy, supplied into electric grid from the WT, changes dependently on this angle and pulse width.

WT can be switched out at the cut-off wind speed by means of the controlled electronic generator’s switch  $EGS$  and inverter’s switch  $IS$ . Generator’s exiting current  $I_c$  can be controlled by means of switch  $EGS$  and its pulse former  $SPF$ .

Energy supply into electric grid from the wind power conversion system (Fig. 1) can be controlled with period 10 ms. When the shunting circuit is used, amount of reactive power supplied or taken from the grid can be controlled. It depends on the inverting and shunting angles with respect to the grid voltage phase.

### Mathematical description of the WT energy converter

Exact description of electromagnetic processes in circuits of power conversion system given in Fig. 1 is rather complicated. Therefore some simplifications used in theory of converters circuits facilitating its mathematical description will be applied [9, 10]. Converter having circuits with n-phases is being substituted by the equivalent one phase schemes. Power valves are being considered as ideal.

The equivalent scheme of power converter (Fig. 1) received after the application of the mentioned above simplifications is given in Fig. 2. The unmarked diodes show the directions of conductivities in this scheme.

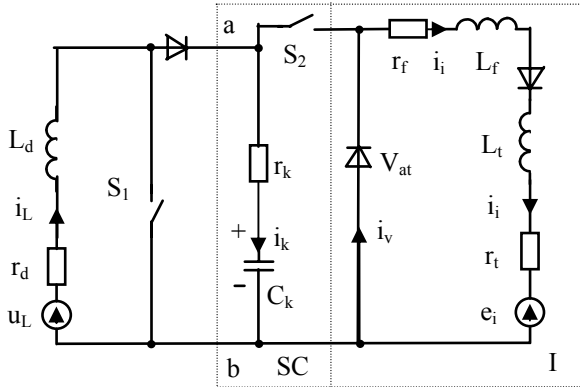

Fig. 2. Equivalent scheme of the power converter

When the wind power source  $u_L, r_d$  is switched into regime of the short circuit by means of the switch  $S_1$  (in case of AC the rectifier is necessary), the power is being laid in store in the choke  $L_d$ . When the  $S_1$  is switched out, the power flows into the storing capacity  $C_k$ . If the  $S_2$  is switched on, inverter  $I$  supplies the power into the electric grid [7]. Pulse width modulation by means of the switch  $S_2$  is used in order to adjust voltages of the wind power source and the electric grid. The grid voltage is used for the modulation. In this way operation of converter is being synchronized with the electric grid. Carrier frequency of the modulated signal usually makes up from few to 20 kHz. Operation of the switch  $S_1$  can be synchronized with the electric grid or not. In our case switch  $S_1$  operates independently from the electric grid voltage.

Mathematical description of the system's power circuits can be made up using the equivalent scheme of converter. The counteracting electromotive force (EMF) of inverter can be calculated by this equation:

$$e_i = E_{im} \cdot \sin\left(\omega \cdot t - \frac{2 \cdot \pi}{m} \pm \varphi\right); \quad (4)$$

where  $E_{im}$  – the maximum value of the inverter's (grid's) linear voltage;  $m$  – the number of pulsations for the inverter scheme;  $\varphi$  – the initial phase angle of the counteracting EMF;  $\omega$  – the cyclic frequency of grid voltage.

However this equation is valid only for the first interval – for the inversion. Equation of the counteracting electromotive force suitable for all intervals of operation can be made up by means of Heaviside functions. Then

equation of the inverter's counteracting electromotive force will shape up as follows:

$$e_i = E_{im} \sum_{k=0}^{\infty} F(t - k \cdot T') \cdot \sin\left[\omega \cdot (t - k \cdot T') - \frac{2 \cdot \pi}{m} - \varphi\right],$$

$$F(t - k \cdot T') = 1(t - k \cdot T') - 1[t - (k + 1) \cdot T'], \quad (5)$$

where  $T' = T/m$  – duration of operating interval,  $T$  – period of grid voltage,  $k = 0, 1, 2, 3, \dots$  – natural numbers.

Like as in reference [9], system of equations for the inversion regime can be made up as follows:

$$\begin{cases} \frac{di_L}{dt} = \frac{1}{L_d}(u_L - u_{ab} - r_d \cdot i_L); \\ \frac{di_i}{dt} = \frac{1}{L_i}(u_{ab} - e_i - r_i \cdot i_i); \\ \frac{du_c}{dt} = \frac{1}{C_k} \cdot i_k; \\ u_{ab} = u_c + r_k \cdot i_k; \\ i_k = i_L - i_i, \end{cases} \quad (5)$$

where  $e_i$  – the counteracting electromotive force of the grid;  $r_i = r_t + r_f$  – the active resistance of the inverter circuit;  $r_t$  – the active resistance of the grid;  $r_f$  – the active resistance of the filter;  $L_i = L_t + L_f$  – the inductance of the inverter's circuit;  $L_t$  – the inductance of the grid;  $L_f$  – the inductance of the filter;  $i_i$  – the inverted current;  $i_v$  – the current of the backward diode;  $V_{at}$  – the backward diode.

In the equivalent scheme the generator is presented as the source of voltage  $u_L$  (Fig. 2). Therefore more detailed mathematical description of the generator is carried out as in the reference [10]. Asynchronous wound-rotor generator can be described by means of the system of differential and algebraic equations as follows:

$$\begin{cases} \frac{di_L}{dt} = \frac{1}{L_d}(u_L - r_d \cdot i_L - u_{ab}); \\ \frac{d\omega_g}{dt} = \frac{1}{J}(M_t - M_g); \\ M_g = \frac{k_1}{\omega_{g0}} \left( E_{2V} \cdot i_L - \frac{i_L^2 \cdot x_v}{\sqrt{2}} \right); \\ M_t = \frac{P_t}{\omega_g \cdot i}; \\ u_L = e_L - u_2 - u_1 = k_1 \cdot E_{2V} \cdot s - u_2 - r_s \cdot i_L; \\ u_2 = 2 \cdot r_2 \cdot i_L + 2 \cdot L_v \cdot \frac{di_L}{dt}; \\ r_s = \left( 2 \cdot r_1' + \frac{3 \cdot x_v}{\pi} \right) \cdot s; \\ s = 1 - \frac{\omega_g}{\omega_{g0}}, \end{cases} \quad (6)$$

where  $M_g$  – the torque of generator;  $M_t$  – the torque of wind rotor;  $J$  – the moment of inertia;  $\omega_g$  – the rotational speed of generator;  $\omega_{g0}$  – the synchronous rotational speed of generator;  $k_1$  – the coefficient of rectifier's scheme;  $E_{2V}$

– the rated electromotive force of rotor;  $x_v$  – the inductive reactance of generator’s winding;  $i_L$  – the rectified current of the rotor’s circuit;  $u_l$  – the rectified voltage of the rotor’s circuit;  $u_i$  – the rectified voltage of the inverter;  $r_d$  or  $L_d$  – the active resistance and inductance of the rectifying choke;  $e_L$  – the rectified electromotive force of the generator’s rotor;  $s$  – the slip of the rotor;  $u_2$  – the voltage drop on generator’s winding;  $u_1$  – the voltage drop on the generator’s winding depending on the slip;  $r_2$  or  $r_1$  – the active resistances of the generator’s rotor and stator reduced to the rotor’s circuit;  $L_v$  – the inductance of the generator’s winding;  $r_s$  – the active resistance of the slip;  $e_i$  – the rectified electromotive force of the inverter.

Generator is rotated by the wind rotor of wind turbine N27/150. Mathematical description of this WT is based on its power curve, which is given in wind turbine’s technical documentation. Polynomial of the fifth order is used for the approximation of the power curve on purpose to have a sufficient adequacy the mathematical description. So, the power curve of wind turbine N27/150 mathematically can be described by this equation

$$P_t = -16.517 \cdot 10^{-5} \cdot v_w^5 + 0.01881 \cdot v_w^4 - 0.6797 \cdot v_w^3 + 9.1408 \cdot v_w^2 - 27.8 \cdot v_w + 4. \quad (7)$$

Mathematical model (Fig. 3) for the WT’s power conversion can be made up using the systems of equations (5) and (6) as well as equations (4) and (7).

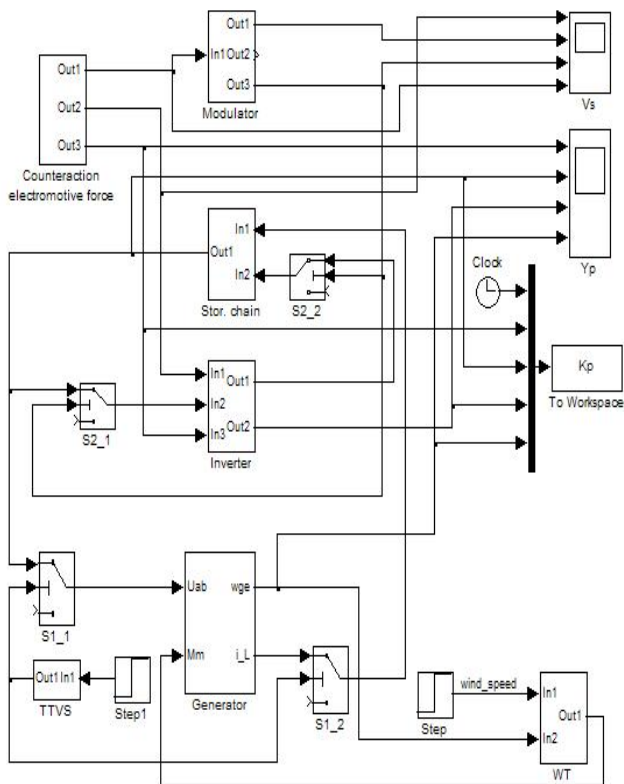

Fig. 3. Mathematical model for the WT’s power conversion

Mathematical model for the WT’s power conversion consist of three functional parts: the converter, which includes inverter, power storage circuit and control pulse former, (unit of counteracting EMF), the unit of modulator and control pulse former of the short-circuiting transistor, and the WT with generator.

### Research of the energy conversion processes

Processes of energy conversion were researched by means of mathematical simulation. Dependence of energy conversion processes on operation of the short-circuiting and storage scheme were researched at the beginning. Pulse width method was used for the control of short-circuiting transistor. Frequency of the control pulses was 2000 Hz. Duration of short-circuiting transistor switching as well as value of the rectified current of the generator’s rotor depends on the control voltage, which is put to the input of the control pulse former SCPF. When the control voltage increases the duration of short-circuiting transistor control pulse decreases while duration of the processes of power storage and inversion increases. When the transient process of WT switching is over, at the 5 second the control voltage  $U_{vtr}$  is jumped. The received curves of the reaction are given in Fig. 4. As we can see, the voltage on terminals of inverter rapidly decreases because the rectified current of generator’s rotor decreases up to zero. However, the rotational speed of WT increases because the torque of generator decreases. The rotational speed of WT will increase further until the new balance between the wind turbine’s active torque and the generator’s reactive torque will be reached. As we can see in Fig. 4, it will take about 5 seconds.

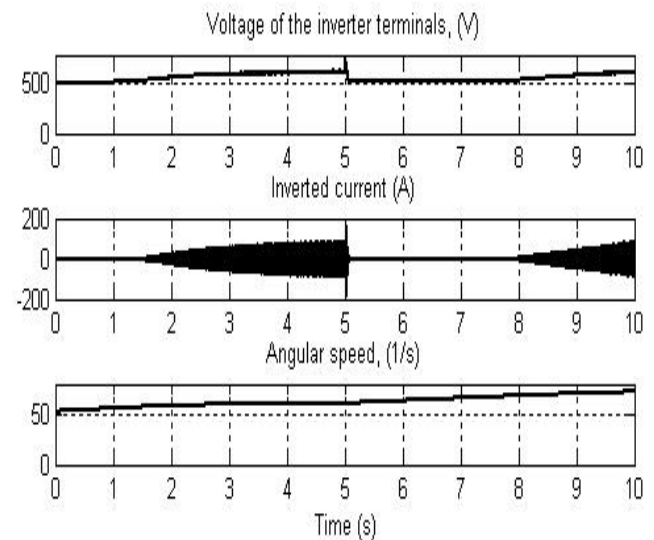
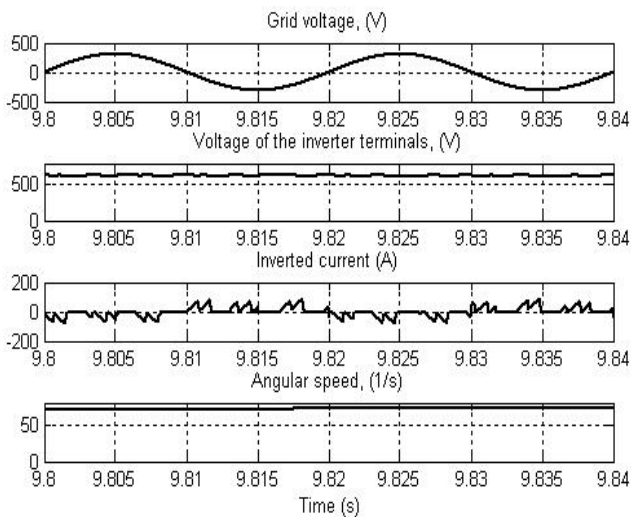

Fig. 4. Curves of the converter’s parameters at jump of the control voltage  $U_{vtr}$  ( $U_{vtr}=0,5 \div 3$  V,  $t=5$  s)

The curves presented in Fig. 5 were received at the same conditions of converter’s operation as in Fig. 4. The form of inverted current is shown in this figure (Fig. 5).



**Fig. 5.** Curves of the converter's parameters when control voltage of the short-circuiting unit  $U_{vir}=3$  V

Operation of the converter at the sudden gust of wind was research as well. The received curves of this research are presented in Fig. 6.

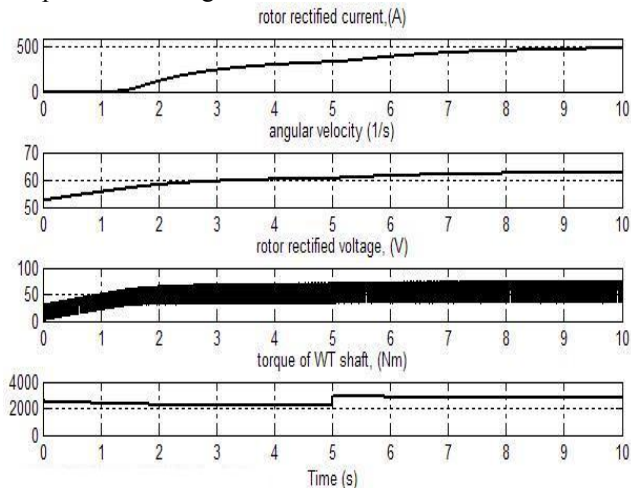

**Fig. 6.** Curves of the converter's parameters at the jump of wind velocity  $v_w$  ( $U_{vir}=0,5$  V,  $v_w=10\div 14$  m/s, o  $t=5$  s)

As we can see from Fig. 6, WT after the jump moves to another point of operation. Rotational speed of the WT, the rectified current and voltage of the generator's rotor increases. Consequently, the power supplied into electric grid increases as well.

## Conclusions

1. Connection of wind turbines into electric grid causes voltage and power fluctuations and flickers, which depend on wind velocity, rated power and number of WT and number of their switching operations.
2. Flickers and fluctuations of voltage and power in the electric grid can be diminished by using the presented scheme for the wind turbine's energy conversion.

3. Electrical scheme of the wind turbine's power conversion system can be simplified by using uncontrolled rectifier in the circuit of generator's rotor.
4. Operation of wind turbine depending on the wind velocity and the control voltage of short-circuiting unit are researched by using the mathematical model built up for the wind turbine with asynchronous wound-rotor generator.
5. Results of the mathematical simulations showed that variations of the control angle of the short-circuiting transistor enables to move the point of wind turbine's operation on its power curve, i.e., to control the quantity of inverted power.

## References

1. **Eur'Observ'ER**, Wind Energy Barometer. Report, 02/2006. Internet address [http://ec.europa.eu/energy/res/sectors/wind\\_energy\\_dissemination\\_en.htm](http://ec.europa.eu/energy/res/sectors/wind_energy_dissemination_en.htm) (accessed 12.03.2007).
2. **RES Scenario** to 2040. Half of the Global Energy Supply from Renewables in 2040. Internet address [www.erec-renewables.org/documents/targets\\_2040/EREC\\_Scenario%202040.pdf](http://www.erec-renewables.org/documents/targets_2040/EREC_Scenario%202040.pdf) (accessed 12.03.2007)
3. **Balčiūnas P., Adomavičius V.** The concept of electric energy conversion in micro-hydro electric power plant // International Conference on Small Hydropower. Proceedings. – Kaunas: Akademija, 23-25 May, 2001. – P. 2-24 – 2-31.
4. **Papathanassiou S. A., Hatzigrygiou N. D.** Technical requirements for the connection of dispersed generation to the grid // IEEE. Abstract, The penetration of Dispersed Generation (DG). – P.6. Internet address [http://users.ntua.gr/stpaph/paper\\_2.38.pdf](http://users.ntua.gr/stpaph/paper_2.38.pdf) (accessed 12.02.2007).
5. **Dubois M. R., Polinder H., Ferreira J. A.** Generator Topologies for Direct Drive Wind Turbines and adapted Technology for Turbines Running in Cold Climate // Delft University of Technology, lab of Electrical Power Processing Mekelweg 4, 2628 CD. – P. 6. Internet address <http://el.itstudelft.nl/epp/Research/Projects%20phD/PB0034.PDF> (accessed 12.02.2007).
6. **ISTEN61400-21** Vėjo turbinų generatorių sistemos. 21 dalis. Į tinklą sujungtų vėjo turbinų energijos kokybės charakteristikų matavimas ir vertinimas (IEC 61400-21).
7. **Rolf Grünbaum.** Voltage and power quality control in Wind Power applications by means of dynamic compensation. ABB Power systems AB, AC Power Division Vasteras. Sweden, P. 15. [http://library.abb.com/GLOBAL/SCOT/scot221.nsf/VerityDisplay/B7EE91B76F899B80C1256FDA003B4D20/\\$File/PQ2000\\_Boston.pdf](http://library.abb.com/GLOBAL/SCOT/scot221.nsf/VerityDisplay/B7EE91B76F899B80C1256FDA003B4D20/$File/PQ2000_Boston.pdf) (accessed 10.02.2007).
8. **Erlich I., Winter W., Dietrich A.** Advanced Grid Requirements for the Integration of Wind Turbines into the German Transmission System // Power Engineering Society General Meeting, IEEE, June 18-22, 2006. – 7 p.
9. **Ramonas Č., Kepalas V., Adomavičius V.** Iš atsinaujinančių šaltinių gautos energijos konversijos procesų tyrimas // Elektrotechnika ir Elektronika. – Kaunas: Technologija, 2006. – Nr. 2(66). – P. 78–83.
10. **Paulauskas M., Kepalas V., Ramonas Č.** Platuminio asinchroninio ventilinio kaskado dinamika // ISSN 1392 - 1215 Elektronika ir elektrotechnika, 1996. – Nr. 4(8). – P. 56–58.

**V. Kepalas, Č. Ramonas, V. Adomavičius. Connection of the RES-based Power Plants into the Electric Grid // Electronics and Electrical Engineering. – Kaunas: Technologija, 2007. – No. 8(80).– P. 67–72.**

Problems caused by the connection of wind turbines into electric grid are discussed. Little by little number of grid-connected wind turbines in Lithuania is increasing and already makes up over 10 MW. Connection of wind turbines into electric grid causes side effects – harmonic distortion, low frequency fluctuations of voltage and flicker emissions. Paper describes flicker emissions caused by the switching operations of wind turbines and their dependence on the number of wind turbine at the site, as well as on rated power of wind turbines and other parameters. The ways for reducing impact of the mentioned side effects into quality of grid power are discussed too. Energy conversion diagram for integration of WT into electric grid is presented. The diagram has rectifier of generator's current, short-circuiter and inverter in wind turbine's power conversion chain. The mathematical model is built up for the wind turbine with asynchronous wound-rotor generator. Results of the mathematical simulations showed that variations of the control angle of the short-circuiting transistor enables to move the point of wind turbine's operation on its power curve, i.e., to control the quantity of inverted power. Regularities of the reactive power circulation between generator of wind turbine and grid as well as diminishing of the flicker emissions phenomena can be determined more exactly by means of further researches. III. 6, bibl. 10 (in English, summaries in English, Russian and Lithuanian).

**В. П. Кепалас, Ч. С. Рамонас, В. Б. Адомавичюс. Включение в сеть возобновляемых источников электроэнергии // Электроника и электротехника. – Каунас: Технология, 2007. – № 8(80). – С. 67–72.**

Анализируются проблемы соединения ветреных электростанций с электросетью. Как показывает мировая практика, присоединение ветроэнергетической станции к электросети создает побочные явления. Появляются высшие гармоники и низкочастотные изменения напряжения сети, вызывающие так называемое мерцание. В статье анализируются некоторые схемы и методы, применяемые для уменьшения мерцаний. Также предлагается схема ветреной электростанции с широтно-импульсным блоком накопления электроэнергии. Создана математическая модель такой ветреной электростанции. Результаты моделирования показывают, что изменяя напряжение управления блока накопления энергии можно регулировать рабочую точку ветреной электростанции, то есть количество энергии, инвертируемой в электрическую сеть. Дальнейшая работа по этой тематике будет направлена на более точных исследованиях циркуляции реактивной энергии между генератором и электросетью и на уменьшение эффекта мерцания. Ил. 6, библи. 10 (на английском языке; рефераты на английском, русском и литовском яз.).

**V. Kepalas, Č. Ramonas, V. Adomavičius. Atsinaujinančių energijos šaltinių elektrinių įjungimas į elektros tinklą // Elektronika ir elektrotechnika. – Kaunas: Technologija, 2007. – Nr. 8(80). P. 67–72.**

Nagrinėjamos vėjo elektrinių sujungimo su elektros tinklu problemos. Lietuvoje, kaip ir visame pasaulyje, didėja vėjo elektrinių, sujungtų su bendru elektros tinklu, įrengtoji galia. Kaip rodo pasaulinė praktika, vėjo elektrinių sujungimas su tinklu sukelia pašalinių efektų. Atsiranda aukštesnių harmonikų srovės. Pasireiškia tinklo įtampos žemojo dažnio svyravimai. Atsiranda vadinamasis mirgėjimo efektas. Straipsnyje nagrinėjama, kaip atsiranda mirgėjimas kintant prie tinklo prijungiamų vėjo elektrinių skaičiui ir galiai, bei metodai, sumažinantys šiuos pašalinius efektus. Pateikiama vėjo elektrinės schema su platuminiu-impulsiniu energijos kaupimo bloku. Sudarytas tokios vėjo elektrinės matematinis modelis. Modeliavimo rezultatai rodo, kad keičiant trumpinimo tranzistoriaus valdymo įtampą, galima reguliuoti vėjo elektrinės darbo tašką, tai yra invertuojamos energijos dydį. Norint tiksliau nustatyti reaktyviosios energijos cirkuliavimo tarp tinklo ir vėjo elektrinės dėsningumus bei sumažinti mirgėjimo efektą, numatoma atlikti tolesnius tyrimus. II. 6, bibl. 10 (anglų kalba, santraukos anglų, rusų ir lietuvių k.).

DOI: 10.5755/j02.eie.11016