

Frequency Gaseous Transducer on the Basis of Structure with an Active Inductive Element

V.S. Osadchuk, A.V. Osadchuk

Vinnitsa National Technical University,

21021, Vinnitsa, Khmelnytsky str 95. Ukraine, phone: (380 0432) 44-08-33, e-mail: osa@lili.vstu.vinnica.ua

Introduction

The frequency transducers have a number of advantages before peak, which consist in considerable boosting of noise immunity, that allows to magnify accuracy of measurements, and also in possibility of obtaining of major output signals. It creates the premises of refusal from amplifying devices in an aftertreatment of signals. Usage of a frequency signal as information allows to refuse A/D converters, that boosts profitability of the measuring equipment [1].

Usage of an active inductive element on the basis of the bipolar transistor with a RC-circuit allows to improve stability of operation of a transducer, because there is not an influence of external electromagnetic fields, and on the other hand, it creates the premises of build-up of the microelectronic circuit of the device according to integrated technology [2].

Now intensive investigations on learning properties of frequency microelectronic transducers [3, 4] are carried on, though the investigations of gaseous frequency transducers are in an incipient state. Therefore given work is devoted to investigations of a base parameters of frequency gaseous transducers on the basis of field-effect and two bipolar transistors.

Experimental investigations

The electric circuit of a transducer is given on fig.1. It represents a hybrid integrated circuit, which consists of three transistors, from which VT1 and VT2 have implement capacitor structure, and the induction structure is created at the expense of the bipolar transistor VT3 and RC-circuit, moreover in a circuit of backward positive connection the gaseous sensitive element of type UST2600 is switched on [2]. On electrodes a drain of the field-effect transistor VT1 and the collector of the bipolar transistor VT2 exists a complete resistance, an which active component has negative value, and reactive one has capacitor character. The connection of an active inductive element on a basis VT3 and chain R_6C_1 to the drain of the field-effect transistor VT1 and collector of the bipolar transistor VT2 creates a tuning circuit, the power losses in which are cancelled by negative resistance.

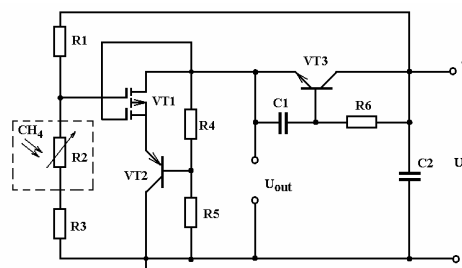

Fig. 1. An electric circuit frequency gaseous transducer

Thus, the resonance frequency of a tuning circuit depends on action of gas on the gaseous sensitive resistor R_2 . The resistances R_1 , R_3 , R_4 , R_5 realize choice of an operating point on a falling section of the voltage-current characteristic. On fig.2 the experimental dependence of resistance of the gaseous sensitive resistor on concentration of methane is represented.

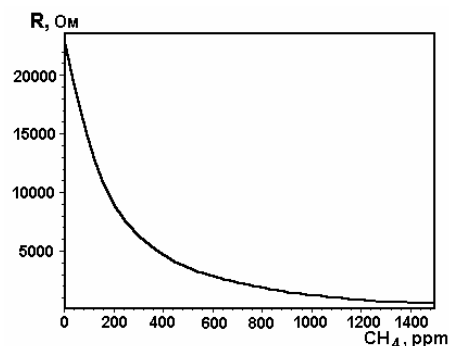

Fig. 2. Dependence of resistance gaseous sensitive the resistor from concentration of methane

The equivalent circuit of a frequency gaseous transducer is represented on fig.3. It takes into account nonlinear properties of the circuit, as the self-excited oscillator can work both in linear, and in nonlinear modes. On the basis of this circuit according to the method Ljapunov [5] the function of conversion of the device is defined which represents dependence of generation frequency on gas concentration, in our case of methane. The analytical dependence of function of conversion has view

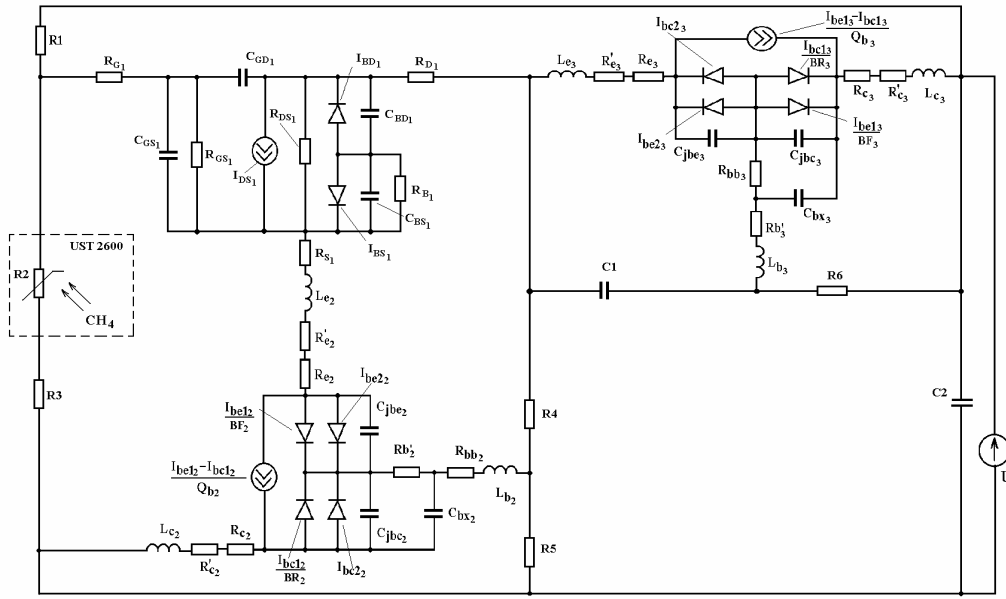

Fig. 3. An equivalent circuit of a frequency gaseous transducer

$$F = \frac{1}{2\pi} \sqrt{\frac{A_1 + \sqrt{A_1^2 + 4B_1 L_{ekv} C_{gd} C_{vx} C_2^2 R_2^2 (CH_4)}}{L_{ekv} C_{gd} C_{vx} C_2^2 R_2^2 (CH_4)}}, \quad (1)$$

where

$$A_1 = (C_{vx} + C_{gd}) C_2^2 R_2^2 (CH_4) + C_{gd} C_{vx} \times R_2^2 (CH_4) C_2 - L_{ekv} C_{gd} C_{vx},$$

$$B_1 = C_{vx} + C_{gd}.$$

The graphics dependence of conversion function is represented on fig.4. The sensitivity of a transducer is defined on the basis of expression (1) and is featured by the equation

$$S_{CH_4}^F = 0.05627 \left(2B_1 C_2 R_2^2 (CH_4) \left(\frac{\partial R_2 (CH_4)}{\partial CH_4} \right) + 2C_{gd} C_{vx} \times C_2 R_2 (CH_4) \left(\frac{\partial R_2 (CH_4)}{\partial CH_4} \right) + \left(\frac{1}{2} (2A_1 (2B_1 C_2^2 R_2^2 (CH_4) \times \left(\frac{\partial R_2 (CH_4)}{\partial CH_4} \right) + 2C_{gd} C_{vx} C_2 R_2 (CH_4) \times \left(\frac{\partial R_2 (CH_4)}{\partial CH_4} \right)) \right) / Y_1 \right) / (L_{ekv} C_{gd} C_{vx} C_2^2 R_2^2 (CH_4) - \left(2(A_1 + Y_1) \left(\frac{\partial R_2 (CH_4)}{\partial CH_4} \right) \right) / (L_{ekv} C_{gd} C_{vx} C_2^2 \times R_2^2 (CH_4)) - \left. \right) / \sqrt{\frac{A_1 + \sqrt{A_1^2 + 4B_1 L_{ekv} C_{gd} C_{vx} C_2^2 R_2^2 (CH_4)}}{L_{ekv} C_{gd} C_{vx} C_2^2 R_2^2 (CH_4)}}, \quad (2)$$

$$\text{where } Y_1 = \sqrt{A_1^2 + 4B_1 L_{ekv} C_{gd} C_{vx} C_2^2 R_2^2 (CH_4)}.$$

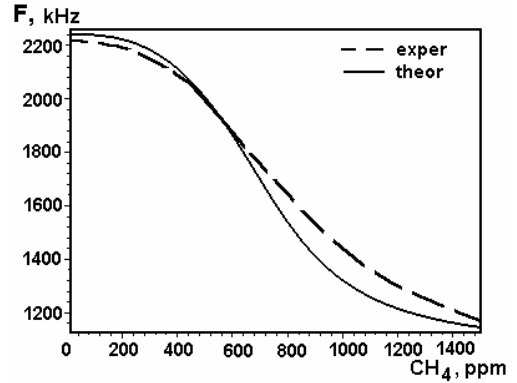

Fig. 4. Dependence of frequency of generation frequency gaseous transducer from concentration of methane

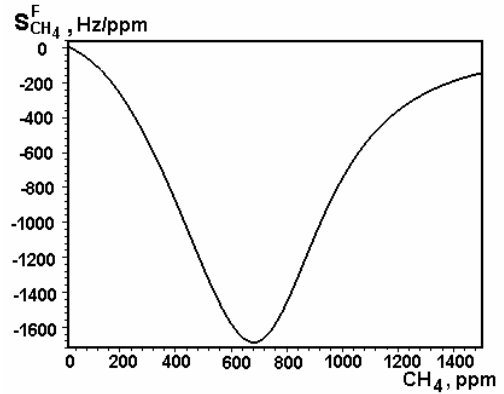

Fig. 5. Dependence of sensitivity on concentration of methane

The schedule of dependence of sensitivity is represented on fig.5. As it is visible from the schedule, the greatest sensitivity of the device lays in the range of concentrations CH₄ from 400 up to 1000 ppm and makes 1 - 1,6 kHz/ppm.

Conclusion

The hybrid circuit of a frequency gaseous transducer is offered on the basis of structure with an active inductive element, that allows to improve operation stability of the device. The analytical dependences of function of conversion and equation of sensitivity are obtained. The theoretical and experimental investigations have shown, that the sensitivity of a frequency gaseous transducer makes 1 - 1,6 kHz/ppm in the range of concentrations CH₄ from 400 up to 1000 ppm.

References

1. **Новицкий П.В., Кноринг В.Г., Гутников В.С.** Цифровые приборы с частотными датчиками. –Л.: Энергия, 1970. – 424 с.
2. **Осадчук В.С., Осадчук А.В.** Реактивные свойства транзисторов и транзисторных схем. –Винница: «Универсум-Винница», 1999. – 275с.
3. **Осадчук А.В.** Микроэлектронные частотные преобразователи на основе транзисторных структур с отрицательным сопротивлением. –Винница: «Универсум-Винница», 2000. – 303 с.
4. **Осадчук В.С., Осадчук А.В., Вербицкий В.Г.** Температурные и оптические микроэлектронные частотные преобразователи. – Винница: «Универсум-Винница», 2001. – 195 с.
5. **Каяцкас А.А.** Основы радиоэлектроники. –М.: Высшая школа, 1988. – 464 с.

Pateikta spaudai 2004 02 02

V.S. Osadčiuk, A.V. Osadčiuk. Struktūrinio induktyvinio elemento dažninis dujų keitiklis // Elektronika ir elektrotechnika. – Kaunas: Technologija, 2004. – Nr. 2(51). –P. 56-58.

Aprašomas naujos kartos induktyvinis dažninis dujų keitiklis, sukurtas mikroelektroninių technologijų pagrindu. Pateikiamos keitiklio analitinių funkcijų išraiškos bei šio keitiklio jautrumo skaičiavimo lygtys. Parodoma, kad teoriniai ir eksperimentiniai rezultatai pakankamai tiksliai sutapo. Keitiklio jautrumas – 1 - 1,6 kHz/ppm. . Il. 5, bibl. 5 (anglų kalba; santraukos lietuvių, anglų ir rusų k.).

V.S. Osadchuk, A.V. Osadchuk. Frequency Gaseous Transducer on the Basis of Structure with an Active Inductive Element // Electronics and Electrical Engineering. – Kaunas: Technologija, 2004. – No. 2(51). –P. 56-58.

In the article investigations of a frequency gaseous transducer are represented on the basis of structure with an active inductive element. The analytical dependences of function of transduction and equation of sensitivity are obtained. The theoretical and experimental investigations have shown, that the sensitivity of a designed frequency gaseous transducer makes 1 - 1,6 kHz/ppm. Ill. 5, bibl. 5 (in English; summaries in Lithuanian, English and Russian).

В.С. Осадчук, А.В. Осадчук. Частотный газовый преобразователь на основе структуры с активным индуктивным элементом // Электроника и электротехника. - Каунас: Технология, 2004. — № 2(51). –С. 56-58.

В данной работе представлены исследования частотного газового преобразователя на основе структуры с активным индуктивным элементом. Получены аналитические зависимости функции преобразования и уравнения чувствительности. Теоретические и экспериментальные исследования показали, что чувствительность разработанного частотного газового преобразователя составляет 1 – 1,6 кГц/ррм. Ил. 5, библи. 5 (на английском языке; рефераты на литовском, английском и русском яз.).

DOI: 10.5755/j02.eie.10976