

Knowledge and Experience Acquisition from Human Motions

S. Hori, S. Hirai, M. Komura

Monotsukuri Institute of Technologists,

333 Maeya, Gyoda 361-0038 JAPAN, Email: hori@iot.ac.jp, <http://www.iot.ac.jp/manu/HORI.html>

H. Taki

Wakayama University

930 Sakaedani, Wakayama 640-8510 JAPAN

Introduction

After-sales service is one of promising business sectors whose market and profit are growing. Improving service technicians' skill is a vital key to quick and efficient service and service experience sharing is proven to improve service productivity. However recording service cases costs high and is a bottleneck of knowledge and experience sharing systems. We propose a framework that records after-service experience and elicits knowledge from the experience. This article describes the knowledge acquisition framework and how IC accelerometers can measure human motions. Empirical results that prove its effectiveness are also shown.

The background and objectives of this research is explained in the following section. Section 2 describes the outline of the proposed method and reviews briefly previous works. Section 3 explains the algorithm of measuring human motion with IC accelerometers as a part of knowledge acquisition.

Background and Objectives

At home and business our society operates many facilities such as home appliances, air-conditioning systems, and power electric equipments. After-sales service is a business exercise such that a dispatched service technician maintains a facility work properly. He or she trouble-shoots and repairs the facility when it is malfunctioning. The after-sales service is now one of the most profitable and fast-growing business sectors. As an example, General Electric launched a jet engine service business in which GE monitors operating jet engines. This service provides airliners with more efficient jet engine operation. Therefore this service reportedly results in high profit to GE.

Advance of information technology enables us easily to monitor and control equipment located in distance. Many expert systems [1, 2] were developed to infer malfunction. They are diagnostic systems that troubleshoot broken equipment and infer malfunctioning parts. Human service technicians learn naturally troubleshooting techniques through a lot of repair cases they experienced. For this reason, previous repair experience is a key information source in order to build a diagnostic knowledge base. Figure 1 outlines this

knowledge-experience cycle with an intelligent system.

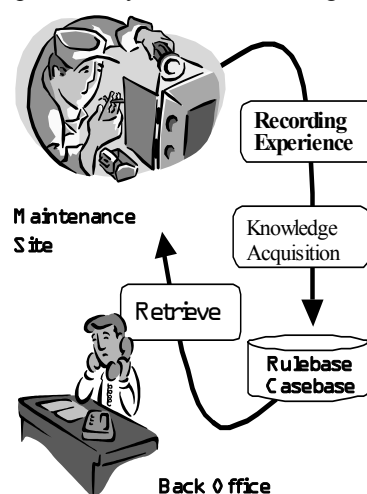

Fig. 1. Knowledge-Experience Cycle

As an intelligent system, CBR, Case-Based Reasoning [3], has been adopted in this field because a previous work [4] also shows that experiment sharing is a good way to support service technicians in troubleshooting. However the bottleneck of these intelligent systems are recording electronically repair cases with lower cost. Therefore a method of recording what a service technician executes at after-service practice has been keenly demanded. A conventional way of recording the cases is letting service technicians to write service reports. Writing service report is very time-consuming task for service technicians, hence this method costs high. Our method measures service technician's motion by electronics sensors, then infers his/her task from the recorded motions. Hence the proposed method requires almost no burden on human technicians to record the maintenance experience.

Knowledge Acquisition from Motion

In this section, our method is outlined, and then previous works is briefly reviewed.

Outline of Proposed Method. The proposed method stores service records as Figure 2 shows. As a result, we can semi-automatically build a casebase of service

experience.

Step - 1. Measure motion accelerations by IC sensors attached to legs and arms of a service technician. Time and location are also recorded.

Step - 2. Decide what basic motion he moved, from the data recorded in step-1.

Step - 3. Infer service task from the series of basic motions elicited at step-2.

Step - 4. Service technician confirms the service task generated in step-3 and adds comment if necessary.

Step - 5. Store the confirmed service task in a casebase as a diagnostic tree form.

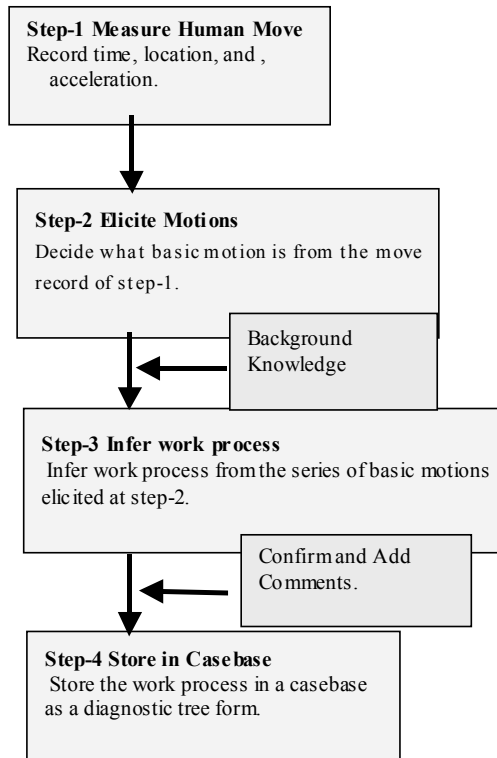

Fig. 2. Knowledge Acquisition from Motion

Previous Works

This section reviews briefly previous works related to ter-service knowledge acquisition. The knowledge acquisition has been recognized as a bottleneck of conventional expert systems. A complete, accurate and updated knowledge base is essential for an expert system to conduct accurate diagnosis. However making a good knowledge base is a time consuming and difficult process. Model-based reasoning [6], rule induction [7] and case-based reasoning [3] have been proposed to overcome this bottleneck. The CBR has been employed for several diagnostic systems [5, 8] because previous troubleshooting experience is often available in the field of diagnosis.

Motion capture techniques are an emerging technology to measure human motions and analyze his/her intention, i.e. including knowledge. Several commercial motion capture system are available, however they cost around a hundred thousands in US dollars. On the other hand, Human motion learning attracts much attention in the field of vision researchers. For example, Song [9] proposes unsupervised learning method of human motion.

Lee and Mase [10] developed a system of activity and

location recognition using wearable sensors, which includes IC accelerometers.

Motion Measurement Algorithm

This section describes how our method measures human motions. First basic motions are defined as Motion study of Industrial Engineering does. Then IC sensors and signal processing algorithm are described.

Motion Study and Therblig. One of the major objectives of Industrial Engineering (IE) is improving productivity in manufacturing lines. In order to achieve this objective, motion study was established. Motion study is a way of analyzing and improving human motions in a work task. Gilbreth defined 18 basic motions of assemble tasks and named them “Therblig” [11]. As Gilbreth claimed, complex human tasks consist of several basic motions. Therefore we defined 8 Therblig symbols for maintenance shown in table 1.

Table 1. Therblig Symbols for Maintenance

Motion	Description	Measurability
R (Reach)	Reach with arm.	○
U (Use)	Push button etc.	×
GR (grip)	Grip handle.	×
IN (Inspect)	Inspect machine status.	△
W (Walk)	Walk	○
SI (Sit)	Sit down	○
RI (Rise)	Rise on foot.	○
WT (Wait)	Wait for machine response	×
TH (Think)	Think	×

Reach” motion is considered most important because this motion is observed when service technician turn on and off a switch. As a next step we employed IC accelerometers to measure Therbligs.

Motion Measuring by IC sensors. We employed IC accelerometers to measure Therbligs. This section describes IC accelerometers and its signal processing. Analog Device’s ADXL202 is employed as an accelerometer. The ADXL202 are low cost, low power, complete 2-axis accelerometers with a measurement range of ± 2 g. Figure 3 shows an accelerometer circuit drawing.

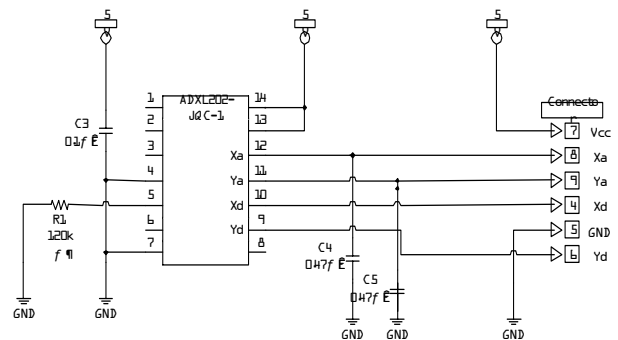

Fig. 3. Accelerometer Circuit Drawing

Data Processing. Two ADXL sensors are attached to right arm as figure 4 shows

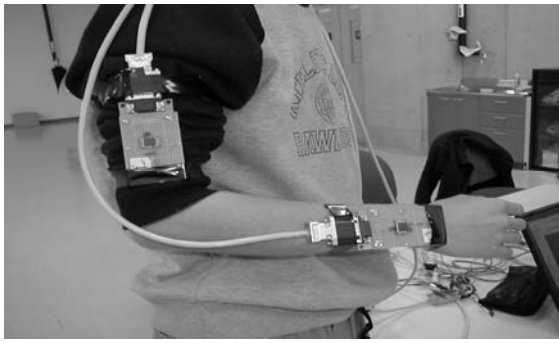

Fig. 4. Accelerometers on Right Arm

Figure 5 demonstrates intuitively How “Reach” motion is detected from the output of wrist ADXL. Right hand are first put aside at a leg. In “Reach” motion, the hand raises and falls. This movement is clearly recorded with ADXL’s X and Y axes sensors.

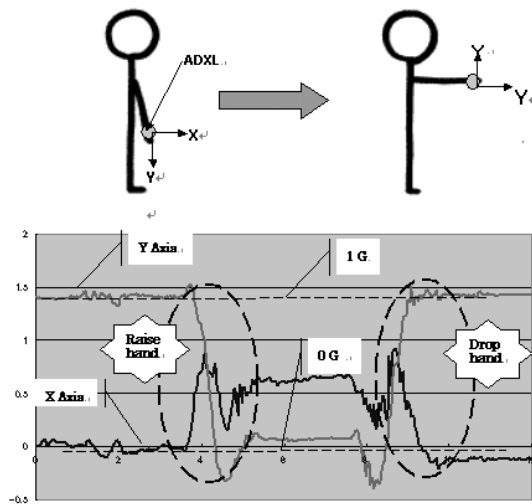

Fig. 5. Wrist Accelerometer’s Output

To detect a basic motion from this data, the output signal is processed as shown in figure 6. An example of the data processing is displayed in figure 7.

Step-□ LPF (Low-Pass Filter) eliminates noise.

Step-□ Labeling: Classify each data in to 5 bins, i.e., “-1”, “-0.5”, “0”, “0.5”, and “1”.

Step-□ Classify: Find the transition of which data becomes -1 to 0. This transition denotes change of arm direction. Therefore we can conclude “Reach” motion occurs.

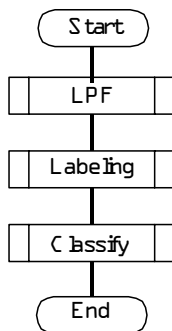

Fig. 6. Signal Processing Flow chart

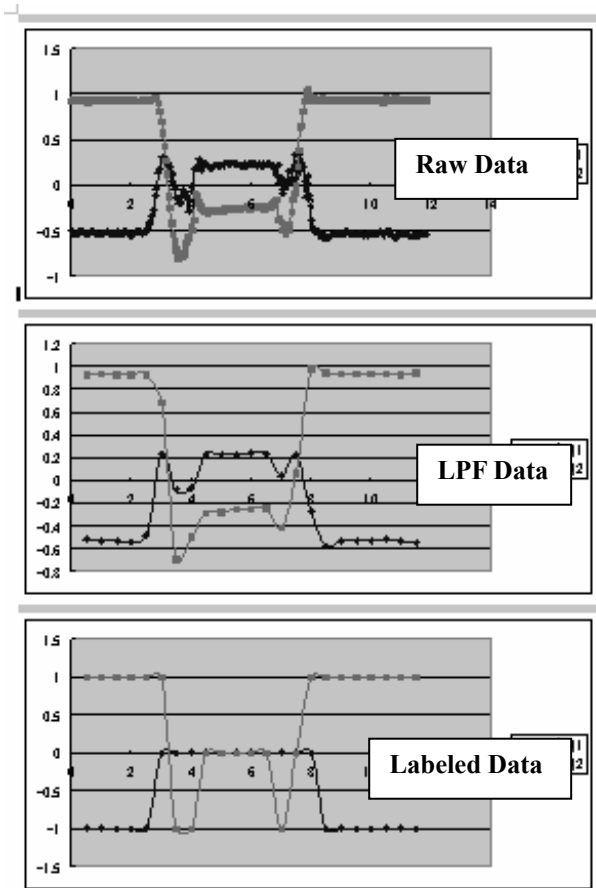

Fig. 7. Processed Signal

Experimental Results. Motion measurement experiment was conducted with 8 people. The signal-processing algorithm detected all of 56 “Reach” motions of the 8 people while they performed a start-up procedure of an industrial robot system that contains 7 Reach motions. Therefore we conclude our method is reliable enough to detect a special motion, e.g., “Reach”, during a service task.

Conclusion. After-sales service is one of promising business sectors. Service experience sharing is proven to improve service productivity. However recording service cases costs high and is a bottleneck of knowledge and experience sharing systems. We proposed a framework that records after-service experience and elicits knowledge from the experience. The proposed method employs IC accelerometers to measure human motions. The empirical results prove that the IC sensors and developed algorithm are able to measure and detect the basic motions while a service technician executes his task.

As the next step, we will continue working to develop the inference mechanism of step 3 in figure 2, which infers service task from a series of observed basic motions.

References

1. Shortliffe E.H. Computer Based Medical Consultations, MYCIN, Artificial Intelligence (1976).
2. Kobayashi S., Nakamura. Knowledge Compilation and Refinement for Fault Diagnosis // IEEE Expert, 1991. - Vol.6, No.5. - P.39-46
3. Hammond K.J. CHEF:A Model of Case-based Planning // Proc. AAAI86. – P.267-271 (1986).
4. Hori S. et al. Utilizing Repair Cases of Home Electrical

- Appliances. IJCAI Practical Use of CBR Workshop. - Nagoya, 1997. – P.41-52.
5. **Kobayashi S., Nakamura K.** Knowledge Compilation and Refinement for Fault Diagnosis // IEEE Expert, Oct. – 1991. - Vol.6, No.5. - P.39-46.
 6. **Kuiper B.** Qualitative Simulation // Artificial Intelligence. - Vol.2. - P.289- 338 (1986).
 7. **Quinlan J.R.** Decision Trees and Decision making // IEEE Trans. on Systems, Man and Cybernetics, 1990. - Vol.20, No.2. - P.339-346.
 8. **Casadaban C.E.** DEB: A Diagnostic Experience Browser using Similarity Networks // NASA Conf. Publication, Vol. NASA-CP-3073. - 1990. - P.517-524.
 9. **Song, Goncalves, Perona,** Unsupervised learning of human motion // IEEE Transactions on Pattern Analysis and Machine Intelligence, 2003. - Vol.25, Iss.7. - P.814-827.
 10. **Seon-Woo Lee, Mase.** Activity and location recognition using wearable sensors // IEEE Pervasive Computing, 2002. - Vol.1, Iss.3. - P.24-32.
 11. **Barnes.** Motion and Time Study // John Wiley & Sons, Inc., 1968.

Pateikta spaudai 2004 03 15

S. Hori, S. Hirai, M. Komura, H. Taki. Žmogaus judesių tyrimai ir eksperimentai // Elektronika ir elektrotechnika. – Kaunas: Technologija, 2004. – Nr. 4(53). –P. 9-12.

Pateikiami eksperimentiniai žmogaus judesių duomenys, gauti IC davikliais. Pasiūlytas būdas, kaip paspartinti žmogaus judesio matavimus IC davikliais. Analizuojami empiriniai pagrindinių judesių tyrimų rezultatai bei algoritmai pilnai. Judesių imitatorius yra techninis personalas, kuris kartu atlieka ir matavimus. Il. 7, bibl. 11 (anglų kalba; santraukos lietuvių, anglų ir rusų k.).

S. Hori, S. Hirai, M. Komura, H. Taki. Knowledge and Experience Acquisition from Human Motions // Electronics and Electrical Engineering. – Kaunas: Technologija, 2004. – No. 4(53). – P. 9-12.

This paper has proposed a framework that records after-service experience and elicits knowledge from the experience. The proposed method employs IC accelerometers to measure human motions. The empirical results prove that the IC sensors and developed algorithm are able to measure and detect the basic motions while a service technician executes the task. Ill. 7, bibl. 11 (in English; summaries in Lithuanian, English, Russian).

С. Гори, С. Гирай, М. Комура, Г. Таки. Познание и эксперименты движения человека // Электроника и электротехника. – Каunas: Технология, 2004. — № 4(53). – С. 9-12.

Описываются экспериментальные данные движения человека, получаемые с помощью IC датчиков. Предлагается новый метод, позволяющий ускорить процесс измерения. Анализируются эмпирические результаты и алгоритмы исследования движения человека. Определяются закономерности имитации движения человека обслуживающим техническим персоналом, который производит процесс измерения. Ил. 7, библи. 11 (на английском; рефераты на литовском, английском и русском яз.).

DOI: 10.5755/j02.eie.10915