

The Ways of Making the Power Transformer's Transformation Coefficient More Precise

A. Kairys, P. Kostrauskas

Kaunas University of Technology, Department of Electric Power systems

Studentu str. 48, LT-51367 Kaunas, Lithuania, e-mail: a.kairys@tkti.lt, phone +370 37 351318

Introduction

The vast majority of investigations [1,2,3,4,5], dealing with leakage of magnetic fields in transformers are limited with the mode of short circuit, when magnetomotive forces of the primary and the secondary windings are equal but polar opposites. It is also supposed that inductive reactance of leakage determined in the short circuit mode does not depend on the transformer's load coefficient. Practically, spatial distribution of the magnetic leakage depends on the transformer's load coefficient: in case of short circuit magnetic leakage is concentrated on the windings and in between them, while in the mode of no-load leakage of magnetic fields of the first winding is significantly bigger and overspread far of the windings. It follows that magnetic fluxes of the transformer's leakage depend not only on the spatial configuration of the windings but also on the operational mode, i.e. on the load coefficient. This factor should be taken into account in the process of projecting, because transformation coefficient defined as a ratio of the voltages of the no-load of the primary and the secondary windings depends not only on the number of turns in these windings but also on their spatial position.

This work deals with a simple method of physical modelling of magnetic leakage of the transformer by means of which a number of turns of the secondary winding is established for the given transformation coefficient.

Theoretical substantiation of the method

Fig. 1 shows ferromagnetic circuit with wound up windings: 1 – the primary excitation winding; 2, 3, ..., n – the secondary dead windings; $w_1, w_2, w_3, \dots, w_n$ – a number of turns in adequate windings; Φ – the main magnetic flux of the primary winding; $\Phi_{\sigma 1}$ – magnetic flux of leakage of the selfinduction of the primary winding; $\Phi_{\sigma 2}, \Phi_{\sigma 3}, \dots, \Phi_{\sigma n}$ – magnetic fluxes of the mutual induction between the primary and secondary windings; w_k, U_k – a number of turns and voltage of the control winding, wound up on the ferromagnetic circuit in such a way that linked magnetic flux of mutual induction is equal to zero.

Let's suppose, that there are no magnetic losses in a magnetic circuit (temporary phases of all magnetic fluxes and the primary excitation winding voltage coincide).

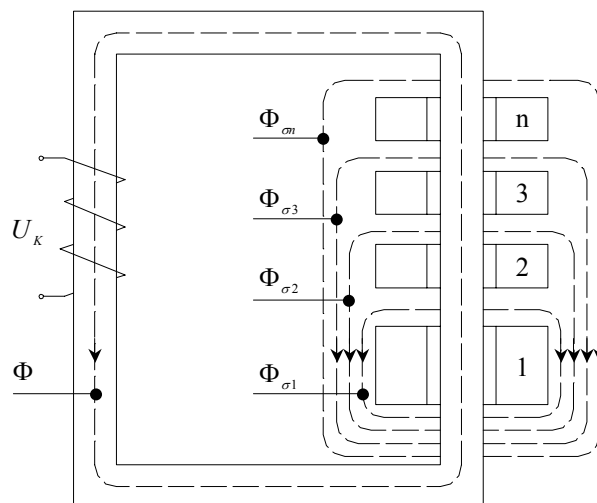

Fig. 1. Ferromagnetic circuit with wound up windings

Voltage of the primary winding U_{01} :

$$U_{01} = \sqrt{R_1^2 I_1^2 + \left[\frac{\omega}{\sqrt{2}} w_1 (\Phi + \Phi_{\sigma 1} + \Phi_{\sigma 2} + \Phi_{\sigma 3} + \dots + \Phi_{\sigma n}) \right]^2}; \quad (1)$$

Where R_1 – active resistance of the primary winding; ω – cyclic frequency of the supply voltage; w_1 – a number of turns of the primary winding.

No-load voltage of the secondary winding U_{02} :

$$U_{02} = \frac{\omega}{\sqrt{2}} w_2 (\Phi + \Phi_{\sigma 2} + \Phi_{\sigma 3} + \dots + \Phi_{\sigma n}); \quad (2)$$

where w_2 – a number of turns of the secondary winding.

No-load voltage of the n^{th} winding U_{0n} :

$$U_{0n} = \frac{\omega}{\sqrt{2}} w_n (\Phi + \Phi_{\sigma n}); \quad (3)$$

where w_n – a number of turns of the n^{th} winding.

No-load voltage of the control winding U_k :

$$U_k = \frac{\omega}{\sqrt{2}} w_k \Phi; \quad (4)$$

where w_k – a number of turns of the control winding.

Desirable transformation coefficient between the primary and secondary windings in no-load conditions:

$$k_{12} = \frac{U_{01}}{U_{02}} = \frac{\sqrt{R_1^2 I_1^2 + \left[\frac{\omega}{\sqrt{2}} w_1 (\Phi + \Phi_{\sigma 1} + \Phi_{\sigma 2} + \Phi_{\sigma 3} + \dots + \Phi_{\sigma n}) \right]^2}}{\left[\frac{\omega}{\sqrt{2}} w_2 (\Phi + \Phi_{\sigma 2} + \Phi_{\sigma 3} + \dots + \Phi_{\sigma n}) \right]}. \quad (5)$$

It can be supposed in medium and high power transformers that $R_1 \approx 0$; then the formula (5) becomes as follows:

$$k_{12} = \frac{U_{01}}{U_{02}} = \frac{w_1}{w_2} \left(\frac{\Phi + \Phi_{\sigma 1} + \Phi_{\sigma 2} + \Phi_{\sigma 3} + \dots + \Phi_{\sigma n}}{\Phi + \Phi_{\sigma 2} + \Phi_{\sigma 3} + \dots + \Phi_{\sigma n}} \right) = \frac{w_1}{w_2} \left(\frac{\Phi + \sum_{i=1}^n \Phi_{\sigma i}}{\Phi + \sum_{i=2}^n \Phi_{\sigma i}} \right). \quad (6)$$

Analogously:

$$k_{13} = \frac{U_{01}}{U_{03}} = \frac{w_1}{w_3} \left(\frac{\Phi + \sum_{i=1}^n \Phi_{\sigma i}}{\Phi + \sum_{i=3}^n \Phi_{\sigma i}} \right); \quad (7)$$

$$k_{1n} = \frac{U_{01}}{U_{0n}} = \frac{w_1}{w_n} \left(\frac{\Phi + \sum_{i=1}^n \Phi_{\sigma i}}{\Phi + \Phi_{\sigma n}} \right). \quad (8)$$

If $w_2 = w_3 = \dots = w_n$, then the transformation coefficients will satisfy the condition:

$$k_{12} : k_{13} : \dots : k_{1n} = \frac{\Phi + \sum_{i=1}^n \Phi_{\sigma i}}{\Phi + \sum_{i=2}^n \Phi_{\sigma i}} : \frac{\Phi + \sum_{i=1}^n \Phi_{\sigma i}}{\Phi + \sum_{i=3}^n \Phi_{\sigma i}} : \dots : \frac{\Phi + \sum_{i=1}^n \Phi_{\sigma i}}{\Phi + \Phi_{\sigma n}}. \quad (9)$$

It can be seen from the latter expression that if all secondary windings have an equal number of turns then their transformation coefficients must increase because fluxes of mutual induction decrease (upon receding of the secondary winding from the primary one).

When the given transformation coefficient is k_{1l} and the given number of the turns of the primary winding is w_1 , a number of the turns of the secondary winding w_l is established according to the formula (8)

$$w_l = \frac{w_1}{k_{1l}} \left(\frac{\Phi + \sum_{i=1}^n \Phi_{\sigma i}}{\Phi + \sum_{i=l}^n \Phi_{\sigma i}} \right). \quad (10)$$

The main magnetic flux Φ and leakage magnetic fluxes $\Phi_{\sigma i}$, $i = 1, 2, 3, \dots, n$, are determined from the following formulas (1) ... (4):

$$\begin{cases} \Phi = \frac{\sqrt{2}}{\omega w_k} U_k; \\ \Phi + \Phi_{\sigma n} = \frac{\sqrt{2}}{\omega w_n} U_{0n}; \\ \Phi + \Phi_{\sigma n} + \Phi_{\sigma(n-1)} = \frac{\sqrt{2}}{\omega w_{n-1}} U_{0(n-1)}; \\ \dots \\ \Phi + \Phi_{\sigma n} + \Phi_{\sigma(n-1)} + \dots + \Phi_{\sigma 2} + \Phi_{\sigma 1} = \frac{\sqrt{2}}{\omega w_1} \sqrt{U_{01}^2 - R_1^2 I_1^2}. \end{cases} \quad (11)$$

In case of n secondary windings, then $(n-l)$ of the leakage flux can be expressed in the following way:

$$\Phi_{\sigma(n-l)} = \frac{\sqrt{2} U_{0(n-l)}}{\omega w_{n-l}} - \frac{\sqrt{2} U_K}{\omega w_K} - \frac{\sqrt{2}}{\omega} \sum_{i=1}^l \frac{U_{0(n-i+1)}}{w_{n-i+1}}. \quad (12)$$

Thus in order to determine necessary number of turns w_l according to the formula (10), which guarantee the given transformation coefficient k_{1l} , it is necessary to know values of the magnetic fluxes Φ and $\Phi_{\sigma i}$, $i = 1, 2, 3, \dots, n$. These magnetic fluxes are functions of the no-load voltage $U_k, U_{01}, U_{02}, U_{03}, \dots, U_{0n}$ (12).

Such definition of the magnetic fluxes of leakage without solution of the equation is preferable because of little time and resources. A number of turns for the secondary windings can be precisely defined from the physical model already in the transformer's designing process thus ensuring the given value of the transformer's coefficient taking into consideration of the winding construction.

Experimental part

Experiment was carried out with a special monophas transformer, showed in fig. 2. Construction measures of the transformer's magnetic circuit and windings are shown in the picture. The primary winding 1 has $w_1 = 139$ turns from the rounded wire and is fixed in the lower part of the magnetic circuit. The secondary winding 2 has $w_2 = 252$ turns from the rounded wire and can slide along the transformer rod ($l = var.$) Control turn 3 is wound up on the upper yoke of the magnetic circuit in such a way that magnetic fluxes of leakage of operating windings wouldn't intersect its turns. A number of turns of control winding $w_k = 16$.

Construction dimensions of the magnetic circuit: $l_1 = 76 \cdot 10^{-2}$ m, $l_2 = 7,6 \cdot 10^{-2}$ m, $l_3 = 15,3 \cdot 10^{-2}$ m; dimensions of the primary winding: $l_4 = 30,8 \cdot 10^{-2}$ m, $l_5 = 40 \cdot 10^{-2}$ m, $l_6 = 13 \cdot 10^{-2}$ m; dimensions of the secondary winding: $l_7 = 26,3 \cdot 10^{-2}$ m, $l_8 = 40 \cdot 10^{-2}$ m, $l_9 = 16 \cdot 10^{-2}$ m; l – variable distance between the primary and the secondary windings.

Distance between the windings l was chosen as follows: $l^{(1)} = 1 \cdot 10^{-2}$ m, $l^{(2)} = 18 \cdot 10^{-2}$ m, $l^{(3)} = 35 \cdot 10^{-2}$ m.

Thus a four-wound transformer was modelled with the following number of the secondary windings $w_2 = w_3 = w_4 = 252$; $R_1 = 0,0877 \Omega$.

Voltages of the no-load were measured by means of a digital voltmeter. Current of the no-load $I_{01} = 0,500$ A was chosen in such a way that the magnetic induction in the magnetic circuit wouldn't exceed 0,2 T.

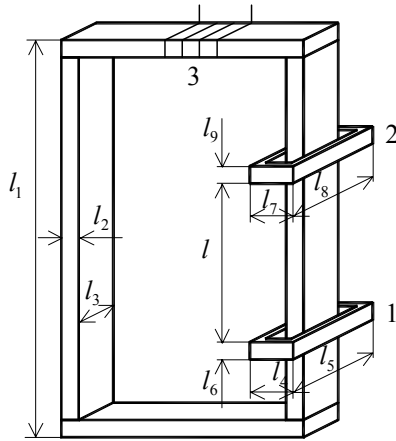

Fig. 2. The transformer of experiment

Results of the various measurements for different distances between the primary and secondary windings are presented below.

Table. Results of measurements for different distances

n	$l^{(n)}$, m	U_{01} , V	I_{01} , A	$U_{0(n+1)}$, V	U_{k_2} , V
1	$1 \cdot 10^{-2}$	67,0	0,500	119,0	7,38
2	$18 \cdot 10^{-2}$	67,0	0,500	117,0	7,38
3	$35 \cdot 10^{-2}$	67,0	0,500	115,8	7,38

The following magnetic fluxes can be defined from the equation system (11) Φ , $\Phi_{\sigma 1}$, $\Phi_{\sigma 2}$, $\Phi_{\sigma 3}$, and $\Phi_{\sigma 4}$:

$$\begin{aligned} \Phi &= 2,077 \cdot 10^{-3} \text{ Wb}, \quad \Phi_{\sigma 1} = 0,4339 \cdot 10^{-4} \text{ Wb}, \\ \Phi_{\sigma 2} &= 0,3646 \cdot 10^{-4} \text{ Wb}, \quad \Phi_{\sigma 3} = 0,2148 \cdot 10^{-4} \text{ Wb}, \text{ and} \\ \Phi_{\sigma 4} &= 0,0781 \cdot 10^{-4} \text{ Wb}. \end{aligned}$$

The coefficients of transformation when leakage fluxes are not estimated:

$$k_{12} = k_{13} = k_{14} = 0,5516.$$

A number of turns of the secondary winding can be defined according to the formula (10).

A number of turns of the secondary winding ($l^{(1)} = 1 \cdot 10^{-2}$ m):

$$w_2 = \frac{w_1 \left(\Phi + \sum_{i=1}^4 \Phi_{\sigma i} \right)}{k_{12} \left(\Phi + \sum_{i=2}^4 \Phi_{\sigma i} \right)} = 257,5$$

A number of turns of the thirdly winding ($l^{(2)} = 18 \cdot 10^{-2}$ m):

$$w_3 = \frac{w_1 \left(\Phi + \sum_{i=1}^4 \Phi_{\sigma i} \right)}{k_{13} \left(\Phi + \sum_{i=3}^4 \Phi_{\sigma i} \right)} = 262,0.$$

A number of turns of the fourthly winding ($l^{(3)} = 35 \cdot 10^{-2}$ m):

$$w_4 = \frac{w_1 \left(\Phi + \sum_{i=1}^4 \Phi_{\sigma i} \right)}{k_{14} \left(\Phi + \Phi_{\sigma 4} \right)} = 264,3.$$

Having chosen the number of turns of the secondary windings in this way, the transformation coefficient of all three windings remains practically constant.

Voltages of the no-load after determination of new number of windings:

$$U'_{02} = 121,83 \text{ V}; \quad U'_{03} = 121,64 \text{ V}; \quad U'_{04} = 121,31 \text{ V}.$$

After correction of the number of turns the new coefficients of the transformation are as follows:

$$k''_{12} = 0,5499; \quad k''_{13} = 0,5516; \quad k''_{14} = 0,5523.$$

Discrepancy of new transformation coefficients does not exceed $\pm 0,5\%$, and this meets standard requirements.

Coefficients of the secondary windings prior to correction of the number of windings ($w_2 = w_3 = w_4 = 252$) in no-load conditions:

$$k'_{12} = 0,5630; \quad k'_{13} = 0,5726; \quad k'_{14} = 0,5786.$$

Deviations of the transformation coefficients from the given $k = 0,5516$ make +4,89%.

Conclusions

Precision of the transformation coefficient is predetermined by the precise definition of the number of turns of the transformer's winding in the designing process. It is known that in case of deviation of the transformation coefficients of the parallel connected transformers in 1%, the rectified current increases in 18% so decreasing the useful transformer's load. Since voltages of the no-load according to which transformation coefficient is established depend not only on the number of winding turns but also on the leakage of magnetic fluxes, so it is obviously necessary to take into account these fluxes.

Given dependencies of the number of turns on leakage of the magnetic fields allow defining a number of turns and transformation coefficient rather precisely. It is shown in this work that the discrepancy of the transformation coefficient in particular transformer makes +4,89% according to the transformation coefficient defined with reference to the ration of the turns of the primary and the secondary windings and to the transformation coefficient according to the data of the idle running, without taking into account influence of the leakage fields on the number of the secondary windings.

A way of defining the number of turns of the secondary windings proposed by us can guarantee that the discrepancy of transformation coefficients will not exceed $\pm 0,5\%$.

References

1. **Richter R.** Elektrische Maschinen, 3. Band, Die Transformatoren. – Basel-Stuttgart: Birkhäuser-Verlag, 1967. – 318 S.
2. **Nürnberg W.** Die Prüfung elektrischer Maschinen einschliesslich der modernen Quersfeldmaschinen. – Moskau: Gosenergo-Verlag, 1959. – 336 S.
3. **Zakrzewski K.** Physical modelling of leakage field and stray losses in steel constructional parts of electro technical devices // Archiv für Elektrotechnik, 1990. – No.69. – S. 319–324.
4. **Zakrzewski K., Lukaniszyn M.** Three-dimensional model of three-phase transformer for leakage field calculation. // Archiv für Elektrotechnik, 1986. – No.73. – S. 129–135.
5. **Bollmann C., Meyer T.** Feldtheoretische Berechnung der Streuinduktivitäten von Leistungstransformatoren mit der Randelementmethode. // Electrical Engineering, 1999. – No.82. – S. 89–97.

Pateikta spaudai 2004 03 12

A. Kairys, P. Kostrauskas. Patikslintas galios transformatoriaus transformacijos koeficiento nustatymas // Elektronika ir elektrotechnika. – Kaunas: Technologija, 2004. – Nr. 6(55). – P. 58–61.

Pateiktas tikslesnis būdas galios transformatoriaus transformacijos koeficientui nustatyti, kai žinomas atstumas tarp pirminės ir antrinių apvijų. Pateiktos priklausomybės tarp magnetinių srautų bei tuščiosios veikos įtampų. Transformacijos koeficientai išreiškiami kaip tuščiosios veikos įtampų ir magnetinių srautų (pagrindinio ir sklaidos) funkcijos. Daugiaapvijo transformatoriaus apvijų vijų skaičius nustatomas taip, kad transformacijos koeficientų (tarp pirminės ir antrinių apvijų) nukrypimas neviršytų $\pm 0,5\%$. Pateiktas daugiaapvijo galios transformatoriaus fizikinis modelis, įgalinantis nustatyti antrinių apvijų vijų skaičių esant nustatytai transformacijos koeficiento vertei. Darbo rezultatai gali būti pritaikyti projektuojant ir skaičiuojant galios transformatorius. Il. 2, bibl. 5 (anglų kalba; santraukos lietuvių, anglų ir rusų k.).

A. Kairys, P. Kostrauskas. The Ways of Making the Power Transformer's Transformation Coefficient More Precise // Electronics and Electrical Engineering. – Kaunas: Technologija, 2004. – No. 6(55). – P. 58–61.

Presented the method of determination transformation coefficient of power transformer, when known distance between primary and secondary windings. Given dependency between magnetic fluxes and no-load voltages. Transformation coefficients are express as functions of magnetic fluxes (main and leakage) and no-load voltages. Formulas are received with estimation of magnetic leakage fluxes for calculation of the number turn windings of multi-wound transformer under given turn ratio with inaccuracy not exceeding $\pm 0,5\%$. Presented physical model of multi-wound power transformer, which allow calculate a number of turns of secondary windings for defined transformation coefficient. The Results of the work can be used when designing power multi-wound transformer with specifically exact transformation coefficient. Ill. 2, bibl. 5 (in English; summaries in Lithuanian, English, Russian).

А. Кайрис, П. Костраускас. Уточненное определение коэффициента трансформации силового трансформатора // Электроника и электротехника. – Каунас: Технология, 2004. – № 6(55). – С. 58–61.

Представлено уточненное определение коэффициента трансформации в зависимости от расстояния вторичных обмоток от первичной в многообмоточном трансформаторе. Представлена зависимость между магнитными потоками (главным и рассеяния) и напряжениями на зажимах обмоток многообмоточного силового трансформатора. На основании полученных данных представлены выражения для коэффициентов трансформации, определяемых в режиме холостого хода. С учетом магнитных потоков рассеяния получены формулы для расчета числа витков обмоток многообмоточного трансформатора при заданном коэффициенте трансформации с погрешностью, не превышающей $\pm 0,5\%$. Обоснована методика на основе физического моделирования по определению числа витков многообмоточных трансформаторов. Результаты работы могут быть использованы при проектировании силовых многообмоточных трансформаторов с особо точными коэффициентами трансформации. Ил. 2, библи. 5 (на английском языке; рефераты на литовском, английском и русском яз.).

