

## Application of Electric Conductivity for Evaluation of Liquid Parameters

J. Daunoras, A. Knyš

Department of Control Technology, Kaunas University of Technology

Studentų str. 48, LT-51367 Kaunas, Lithuania, phone: +370 37 300251, e-mail: dekeaf@ktu.lt

### Introduction

Recently all over the world an increased attention to the quality of the production and quality control of the product is observed. In some cases it starts with control and assurance of the quality of a raw material. The dairy industry is not an exception. In order to supply the customer a highest quality product it is necessary to assure supply of exceptionally good raw milk. For this purpose many countries have one or more laboratories which task is to provide rapid and reliable evaluation result of raw milk quality. It makes possible for dairies to run production on highest quality milk and to reject the inappropriate one.

Traditionally all these laboratories use the same methods for quality evaluation, such as: filter or Fourier spectroscopy for quantitative milk composition measurement, flow-cytometry or DEFT (*Direct Epifluorescence Filter Technique*) for total bacterial count, cryoscopes for milk freezing point depression evaluation etc. It's been proven [1] that it is possible to evaluate milk freezing point depression using milk conductivity, quantitative parameters etc. This makes possible to combine different measurement methods and techniques into one complex analysis system and provide rapid and reliable measurement results.

### Structure of the system

The analysis carried out in [1] points to the fact that, when the specific electrical conductivity of milk is given, it is possible to evaluate its parameters and determine freezing point depression. One must be also aware of the fact that specific electrical conductivity changes [2, 3, 4] (consequently, freezing point depression as well) depending on the temperature and bacterial contamination of the sample during analysis. Taking this into account, the system's structural scheme is presented in Fig. 1.

It presents a detailed structural scheme of the system intended for determination of milk freezing point depression by the indirect method. It shows what analyses have to be performed and what raw data is necessary and

how it is to be processed in order to obtain the result – the freezing point depression. It has been determined that the data required for determination of freezing point depression consists of:

- results on compositional analysis of sample (R, B, L content in milk);
  - specific electrical conductivity G of sample;
  - temperature T of sample during analysis;
  - value of bacterial contamination BBU of sample.
- period of time past sampling until analysis.

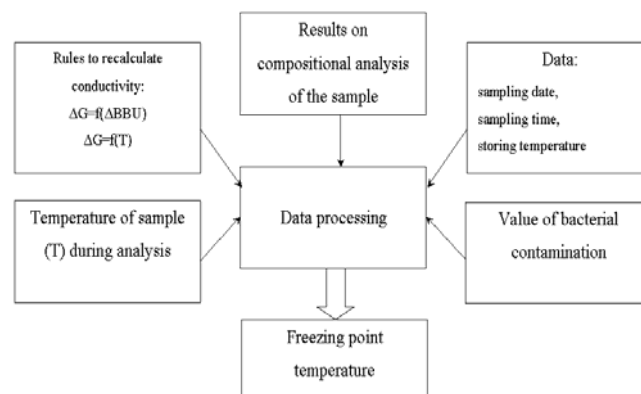

Fig. 1. Structural scheme of system for evaluation of milk freezing point depression

The possible errors due to some external factors when measuring conductivity can be minimized [1] using following formulas (1, 2, 3, 4):

$$G = G_p \cdot (1 + \alpha \cdot (T - 40)); \quad (1)$$

$$\Delta G = 0.95 \cdot e^{0.3(t-38.25)}; \quad (2)$$

$$\Delta G = a \cdot \ln(\Delta BBU) + b; \quad (3)$$

$$\Delta BBU = 0.99 \cdot e^{0.805(t-10)}; \quad (4)$$

where  $G$  – specific electrical conductivity at temperature  $T$ ,  $\text{mS}\cdot\text{cm}^{-1}$ ;  $G_p$  – specific electric conductivity at temperature  $T=40^\circ\text{C}$ ,  $\text{mS}\cdot\text{cm}^{-1}$ ;  $T$  – temperature,  $^\circ\text{C}$ ;  $\alpha$  – temperature coefficient of specific electrical conductivity of milk,  $\text{mS}\cdot\text{cm}^{-1}/^\circ\text{C}$ ;  $\Delta G$  – change in specific electric conductivity,  $\text{mS}/\text{cm}$ ;  $\Delta\text{BBU}$  – change in total bacteria count  $\text{CFU}/\text{ml}$ ;  $a$ ,  $b$  – model's coefficients;  $t$  – time, hours.

As all this data given, it is possible to work out freezing point depression of the sample.

The structural scheme of the compositional analysis module is presented in Fig. 2.

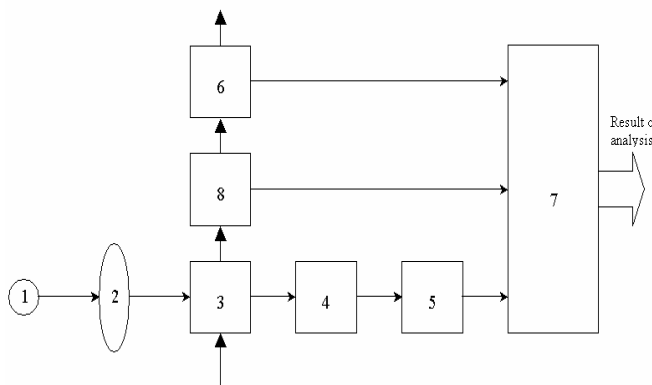

**Fig. 2.** Structural scheme of module for compositional analysis of sample 1 – IR beam source; 2 – optical filters; 3 – cell; 4 – IR source detector; 5 – result recalculation module; 6 – electrode for evaluation of specific electrical conductivity; 7 – module for processing analytical results; 8 – measurer of sample's temperature

During analysis milk is poured into cell 3, which is exposed to IR beams. The beam from source 1 passes through optical IR filters 2, cell 3 to detector 4, which determines the intensity of the beam. The optical filter 2 produces a beam of the required wavelength, which is absorbed by the component under analysis in cell 3. In the calculation unit 5 the intensity of the IR beam is used to evaluate the component concentration. Simultaneously electrical conductivity and the temperature of milk are measured by the electrode for evaluation of specific electrical conductivity 6 and measurer of sample's temperature 8. The results are then passed to module for processing analytical results 7 from which data are send for further processing.

In such a way we obtain four main parameters i.e. compositional parameters (fat, protein, lactose content) and the value of specific electrical conductivity. Using this data we can calculate (5) freezing point depression of milk, however, as the analysis [5, 6] has shown, the error of result is influenced by other factors as well, namely, temperature of the sample during analysis and bacterial contamination. These factors can be taken into account using (1, 2, 3, 4) formulas

$$T_{uzs} = \sum_{i=1}^4 a_i x_i . \quad (5)$$

Fig. 3 presents a scheme of sample analysis process. From Fig. 3 it follows that prior to object testing for fat,

protein and lactose content (simultaneously measuring conductivity) sample's total bacterial contamination and temperature has to be evaluated in order to carry out correction of conductivity value. Afterwards, knowing all the parameters (fat R, protein B, lactose L content, temperature T, bacterial count BBU, conductivity G and time span past sampling) and using (1, 2, 3, 4) formulas correction of conductivity is carried out and milk freezing point depression is calculated.

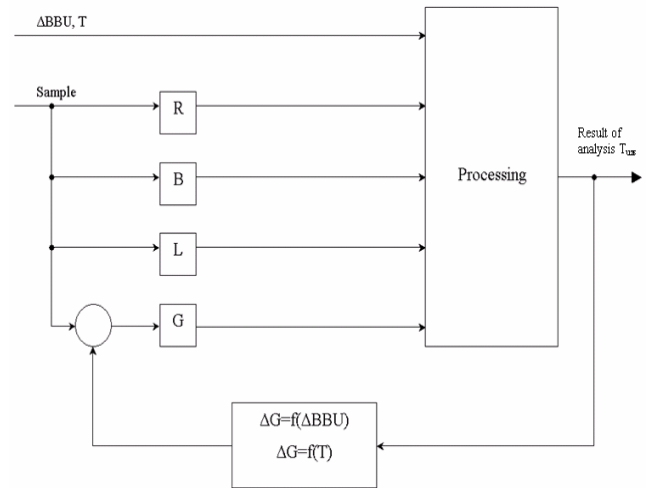

**Fig. 3.** Scheme of sample analysis process: sample – object being tested; data – temperature of sample during analysis, time-span past sampling until analysis, total bacteria count; R, B, L – results of analysis on fat, protein, and lactose content, respectively; G – value of specific electrical conductivity; processing – set of rules on recalculation of specific electrical conductivity depending on relevant factors.

### Algorithm of analysis

The algorithm of the system's (Fig. 1) operation control is represented in Fig. 4. It contains the step sequence of the analysis:

1. Sample is loaded onto the analytical system;
2. Supplementary data is presented: total bacteria count in sample, temperature, time-span past sampling until testing;
3. Composition of sample (R, B, L, G) is determined during analysis;
4. Correspondence of determined parameters to those of natural milk composition is verified. In case of correspondence, recalculation of specific electrical conductivity recalculation in accordance with the set rules is performed taking into account total bacteria count, temperature of sample, time-span past sampling until testing and then the result of analysis on freezing point depression is delivered. If parameters fail to correspond to those of natural milk, the analysis is repeated. If discrepancy is confirmed, the result of analysis is not delivered; a notification of an error is issued instead, which informs that evaluation of milk freezing point depression by this method is not possible.

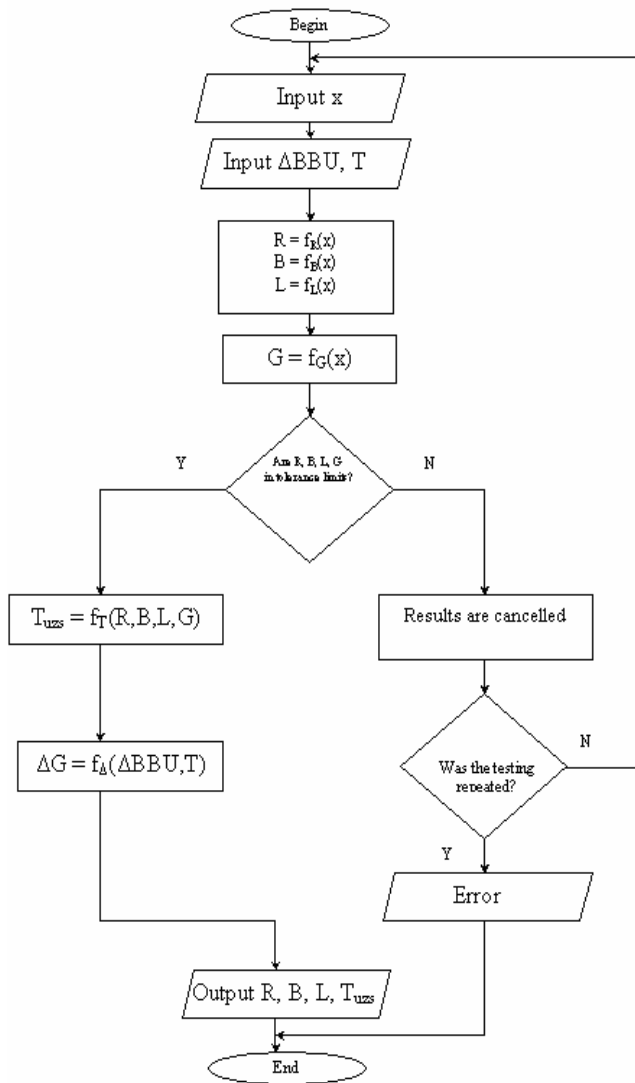

Fig. 4. The algorithm of operation control

## Experiment

To evaluate the effectiveness and reliability of the system analysed some experiments were carried out [1]. Table 1 represents some of the experimental results acquired measuring milk sample and calculating. Freezing point depression was evaluated using (6) [1]:

Table 1. Experimental results of sample analysis

No.	R, %	B, %	L, %	G, mS/cm	BBU, KSV/ml	t, val.	T <sub>tyr</sub> , °C	T <sub>uzsK</sub> , °C	T <sub>uzsA</sub> , °C	ΔT, °C
1	4.14	3.16	4.70	6.67	142	12	40.1	-0.526	-0.527	-0.001
2	5.38	2.69	4.50	7.12	34	14	40.3	-0.534	-0.533	0.001
3	4.45	3.65	4.77	6.20	-	11	39.8	-0.524	-0.526	-0.002
4	3.85	3.09	4.50	6.87	73	3	39.9	-0.518	-0.517	0.001
5	4.16	3.18	4.74	6.32	134	6	40.5	-0.522	-0.519	0.003
6	5.09	3.71	4.45	6.61	68	14	39.6	-0.525	-0.525	0
7	4.20	3.25	4.73	6.75	-	14	39.9	-0.532	-0.534	-0.002
8	4.31	2.93	4.79	6.80	123	6	40.2	-0.537	-0.536	0.001
9	4.17	3.25	4.75	6.75	-	13	40.1	-0.534	-0.535	-0.001
10	4.19	3.13	4.59	7.21	92	12	39.7	-0.539	-0.537	0.002

$$T_{uzs} = 0.0612 - 0.0085R - 0.0136B - 0.0641L - 0.0314G. \quad (6)$$

Table 1 has the following abbreviations: R, B, L – fat, protein and lactose content respectively; G – conductivity; BBU – total bacterial contamination; KSV – colony forming units; t – time; T<sub>tyr</sub>, T<sub>uzsK</sub>, T<sub>uzsA</sub> – sample's temperature during measurement, freezing point depression (reference) and freezing point depression (calculated) respectively; ΔT – temperature estimation error.

Fig. 5 shows the change of mean value of the freezing point depression estimation error compared to absolute freezing point depression value. It is evident, that minimum value of the error is achieved, when freezing point value is around -0.528°C. Statistical evaluation of experimental data showed that difference to reference of no more than 95% of calculated freezing point depression values will not be higher than ±0.003°C and the coefficient of variation CV=0.0182. Pearson's correlation coefficient

$$r = \sqrt{\frac{\sum(UT_{uzsA} - \overline{UT_{uzsA}})^2}{\sum(UT_{uzsK} - \overline{UT_{uzsK}})^2}} = 0.9822. \quad (7)$$

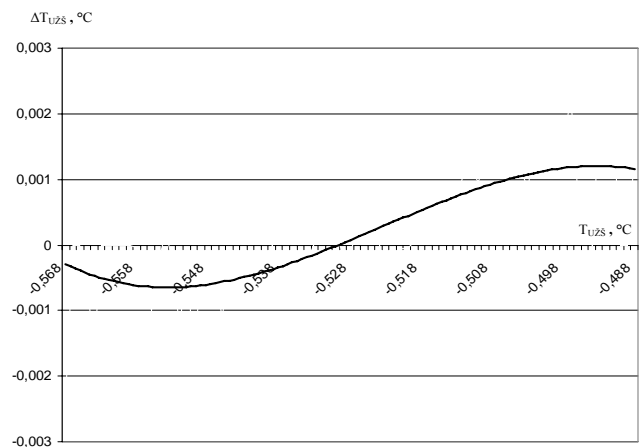

Fig. 5. Error of freezing point depression estimation

## Conclusions

1. Application of scheme (Fig. 1) for milk analysis and freezing point depression eliminates cryoscopic analysis out of the analysis process of raw milk replacing it with freezing point prediction (calculation).

2. Maximum expectable error when calculating freezing point depression out of milk compositional parameters and taking into account additional factors (temperature, bacterial contamination etc.) would not exceed  $\pm 0.0045^{\circ}\text{C}$  ( $S_d=0.0015$ ).

3. Fig. 5 shows that minimum value of the estimation error is achieved when freezing point depression is around  $-0.528^{\circ}\text{C}$ , that is near to a critical zone of  $-0.520^{\circ}\text{C}$  above which extraneous water in milk is suspected [5].

## References

1. **Knyš A.** Elektrinio laidžio modeliavimas pieno struktūroms kompleksiai tirti : Daktaro disertacija. – Kaunas, KTU. – 2006.
2. **Silley P., Forsythe S.** Impedance Microbiology – A Rapid Change for Microbiologists // Journal Applied Bacteriology 80. – 1996. – P. 233-243.
3. **Gomez R., Bashir R., Sarikaya A., et al.** Microfluidic Biochip for Impedance Spectroscopy of Biological Species . Biomedical Microdevices 3. – 2001. – P. 201–209.
4. **Castro G. R., Andribet L. M., Ducrey L. M., et al.** Modelling and Operation of a Turbidity Meter for On-line Monitoring of Microbial Growth // Process Biochem. 30. – 1995. – P. 767–772.
5. **Daunoras J., Knyš A.** Skysčių specifinio elektrinio laidumo nustatymas ir jo kompensavimo sistema // Elektronika ir elektrotechnika. – Kaunas: Technologija, 2005. – Nr. 7(63). – P. 44–48.
6. **Daunoras J., Knyš A.** Research into Correlation of Milk Electrical Conductivity and Bacterial Contamination // Electronics and Electrical Engineering. – Kaunas: Technologija, 2006. – No. 6(70). – P. 95-98.

Submitted for publication 2007 04 17

### **J. Daunoras, A. Knyš. Application of Electric Conductivity for Evaluation of Liquid Parameters // Electronics and Electrical Engineering. – Kaunas: Technologija, 2007. – No. 7(79). – P. 37–40.**

An application of electric conductivity for evaluation of liquid parameters is analysed. Means and methods of analysis that are currently used all over the world to assure quality in dairy industry are surveyed. Presented are data on complex analysis system for milk freezing point depression evaluation using indirect method – system schematics, control algorithm, samples quantitative evaluation schematics, correction on electric conductivity measurement result according to temperature and total bacterial contamination together with milk freezing point depression calculation formula. Essential data for system functioning and succession of presentation of it is described. Experimental data and statistic evaluation is presented. Ill. 5, bibl. 6 (in English; summaries in English, Russian, Lithuanian).

### **Й. Даунорас, А. Книш. Применение специфической электрической проводимости для оценки параметров жидкостей // Электроника и электротехника. – Каунас: Технология, 2007. - № 7(79). – С. 37–40.**

Анализируется применение специфической электрической проводимости для оценки параметров жидкостей. Дается обзор в мире употребляемых средств, мер и методов анализа для обеспечения качества молока. Представлены данные о комплексной системе, предназначенной для прогноза температуры замерзания молока косвенным путём – схема системы, алгоритм управления, схема анализа состава образца, методы уточнения результата измерения специфической электрической проводимости молока с учётом температуры образца и его бактериального загрязнения, представлена формула вычисления температуры замерзания. Определены обязательные данные для работы системы и последовательность представления их системе. Описаны экспериментальные данные, дана их статистическая оценка. Ил. 5, библи. 6 (на английском языке; рефераты на английском, русском и литовском яз.).

### **J. Daunoras, A. Knyš. Savitojo elektrinio laidžio panaudojimas skysčių parametrams įvertinti // Elektronika ir elektrotechnika. – Kaunas: Technologija, 2007. – Nr. 7(79). – P. 37–40.**

Nagrinėjamas pieno savitojo elektrinio laidžio taikymas skysčių parametrams įvertinti. Apžvelgiamos pasaulyje pieno kokybei užtikrinti naudojamos priemonės, tyrimo metodai. Pateikiami duomenys apie kompleksinę tyrimo sistemą, skirtą pieno užšalimo temperatūrai nustatyti netiesioginiu būdu – sistemos schema, valdymo algoritmas, mėginio sudėties tyrimo schema, savitojo elektrinio laidžio įvertinimo tikslinimo, atsižvelgiant į mėginio temperatūrą, bendrąjį bakterinį užterštumą, būdai, formulė užšalimo temperatūrai apskaičiuoti. Apibrėžiami būtini duomenys tyrimo sistemai funkcionuoti ir pieno užšalimo temperatūrai apskaičiuoti, nurodomas šių duomenų pateikimo tyrimo sistemai eiliškumas. Pateikiami eksperimentiniai tyrimo rezultatai, jų statistinis įvertinimas. Il. 5, bibl. 6 (anglų kalba; santraukos anglų, rusų ir lietuvių k.).

DOI: 10.5755/j02.eie.10835