

Research of Deflection System Magnetic Field Approximation

V. Čepulis, D. Navikas, M. Čepulis

Department of Electronics Engineering, Kaunas University of Technology,

Studentu str. 50-422, LT-51368 Kaunas, Lithuania, e-mail: vidas.cepulis@ktu.lt, dangirutis.navikas@ktu.lt

Introduction

In the electronic-optical system (EOS) modeling process one of the modeling stages is calculation of electron trajectories in magnetic fields (MF). Electron trajectories modeling procedure demands MF strength components values in particular point of space. This task can be solved by adequate modeling deflection system construction and MF strength. Precise modeling of deflection system is complicated, because MF is created by multiplex construction sources: deflection yokes, magnetically soft ferromagnetic parts and permanent magnets. Moreover, include MF calculation procedure to electron trajectories calculation process beside the purpose, because one trajectory calculation will last a few hours. Trajectories calculation task can be divided in two stages: in the first stage in space grid particular nodes MF strength values are calculated, in the second stage MF strength components values in demanded points of space (by electron trajectories calculation procedure) are calculated using values approximation or interpolation. According that conception MF strength components approximation and interpolation accuracy and speed problems were analyzed

Base exploratory MF were taken dual:

1. Approximation errors are more presumable when MF structure is “curved”. Permanent magnets and magnetically soft ferromagnetic parts are far away from electron trajectories zone, meanwhile deflection system yokes (especially horizontal deflection yokes) are located near this zone and therefore as MF source was taken a pair of horizontal deflection single-wire yokes (Fig. 1). Yoke construction parameters are: $R_1=10$; $R_2=60$; $z_0=60$; $z_1=80$; $z_2=130$; $\alpha=10^\circ$. That yoke will create much “curved” MF structure, because near wire MF strength will vary by module and direction. MF strength values of that yoke can be calculated using superposition method, summarizing appropriate components values created by each yoke elements – straight conductor or part of arc conductor.

Expressions of MF strength components are attained resolving Poisson vectoric equation of magnetostatics [1].

For straight conductor parallel to Z axis:

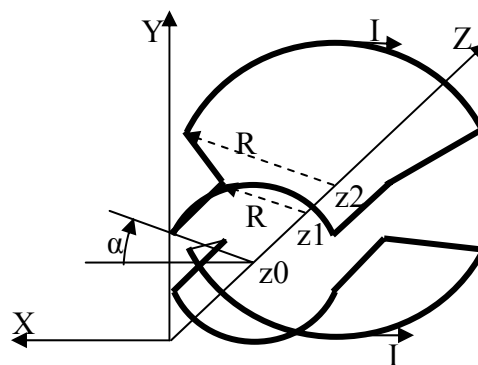

Fig. 1. Single-wire horizontal deflection system

$$H_x = -\frac{I \cdot (x - x_m)}{4 \cdot \pi} \int_{z_1}^{z_2} \frac{dz_m}{r^3}, \quad (1)$$

$$H_y = -\frac{I \cdot (y - y_m)}{4 \cdot \pi} \int_{z_1}^{z_2} \frac{dz_m}{r^3}, \quad (2)$$

$$H_z = 0; \text{ where } r = \sqrt{(x - x_m)^2 + (y - y_m)^2 + (z - z_m)^2}.$$

For part of arc conductor, which plane is perpendicular to axis Z:

$$H_x = \frac{I \cdot R_m \cdot (z - z_m)}{4 \cdot \pi} \int_{\alpha_1}^{\alpha_2} \frac{\cos \alpha_m \cdot d\alpha_m}{r^3}; \quad (3)$$

$$H_y = \frac{I \cdot R_m \cdot (z - z_m)}{4 \cdot \pi} \int_{\alpha_1}^{\alpha_2} \frac{\sin \alpha_m \cdot d\alpha_m}{r^3}; \quad (4)$$

$$H_z = -\frac{I \cdot R_m}{4 \cdot \pi} \int_{\alpha_1}^{\alpha_2} \frac{(R \cdot \cos(\alpha_m - \beta) - R_m) \cdot d\alpha_m}{r^3}; \quad (5)$$

where $r = \sqrt{(z - z_m)^2 + R^2 + R_m^2 - 2 \cdot R \cdot R_m \cdot \cos(\alpha_m - \beta)}$; index m shows, that point belongs to conductor in which current I flows; R_m – radius of part of arc; x, y, z, R, β – point of space Cartesian and polar coordinates.

MF of elements in the cone part is calculated using coordinate system rotation on purpose that conductor in a new system will be parallel to new Z axis.

All “active” MF space was divided to forty 5 mm length blocks. Each block has 6 planes perpendicular to Z

axis (distance between planes – 1 mm). Blocks dimensions are variable according the form of electron trajectory (Fig. 2).

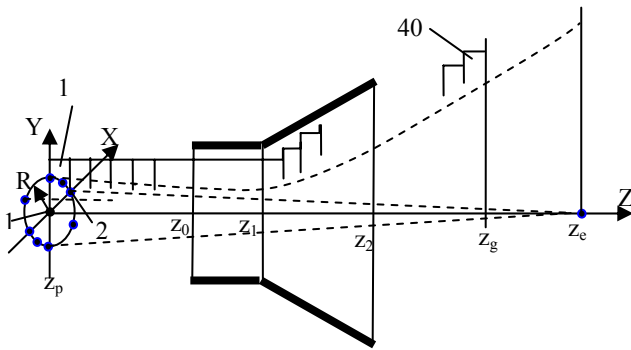

Fig. 2. Blocks of base MF and typical electron trajectories

In each planes quadrant is created square grid with 1 mm step (Fig. 3).

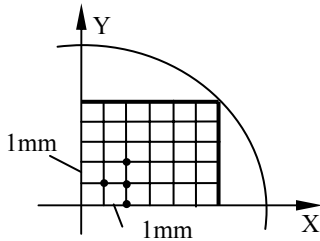

Fig. 3. Nodal points of base MF plane

2. The second base exploratory MF is created by real TV deflection system without permanent magnets. This field was estimated using MF created by horizontal and vertical deflection yokes and soft ferromagnetic parts measurement and expansion to measurement space inside [2]. MF strength components values were found in analogous (first case) space grid nodes.

For approximation analysis various procedures were created in Matlab. Initial electron trajectories were calculated by interpolating MF strength values from total data using standard Matlab interpolation procedures. A conclusion was made that method is prospectless, since one electron trajectory calculation lasts in tens minutes.

Deeper analysis has shown, that calculation process is slowed down regarding quantity of conditional operators „if“. To reduce calculation time, the calculation was performed by finding and then interpolating data in particular spatial block. In that case calculation speed increases ten times and lasts a few minutes.

At last, calculation time was reduced using together with flying electron „running“ spatial block. In that case the is no need to search particular spatial block and interpolation is performed only in one particular block. Calculation lasts about 10-20 s. Finally MF components symmetry and summarized MF components data blocks were used in order to reduce calculation time. Considering these factors, one electron trajectory calculation lasts 2-8 s.

Maybe calculation speed can be increased using base magnetic field strength components approximation by

analytical expressions.

From many possible approximation variants was chosen MF components approximation by two-dimensional power polynomials. For example horizontal deflection MF components can be approximated (taking into account symmetry conditions) as follows:

$$H_x = a_1xy + a_2x^3y + a_3xy^3 + \dots; \quad (6)$$

$$H_y = b_1 + b_2x^2 + b_3y^2 + b_4x^4 + b_5y^4 + b_6x^2y^2 + \dots; \quad (7)$$

$$H_z = c_1y + c_2x^2y + c_3y^3 + c_4y^5 + c_5x^2y^3 + c_6x^4y + \dots; \quad (8)$$

where coefficients a_i , b_i , c_i in particular approximation plane z are constant; in the other plane coefficients will have other values.

Changing x with y in (6-8) expressions we will have vertical deflection MF components approximation power polynomials.

Coefficient values in each plane are founded using least square method. Analysis has shown, that coefficient values variation along Z axis is multiplex, so approximation using z -functions is questionable – small approximation errors causes inadmissible MF component errors, therefore coefficients values were calculated using interpolation to inter-plane points.

In Fig. 4 there is shown single-wire deflection system horizontal deflection MF base (a) and approximated by 5th order power polynomial (b) main component (H_y)

variation in the one of z -planes (with most complicated MF structure). Analogous dependences when approximation power polynomial is only 3rd order are shown in Fig. 5. The same dependences of real deflection system vertical deflection MF are shown in Fig. 6-7.

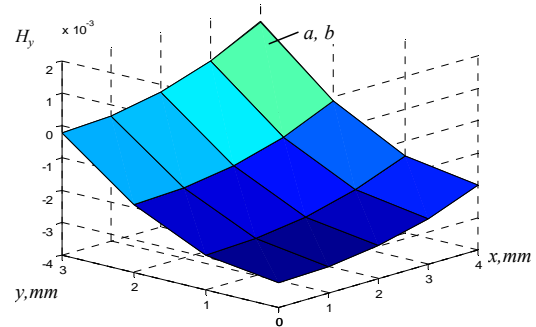

Fig. 4. Single-wire deflection system MF component H_y (a), approximated by 5th order power polynomial (b)

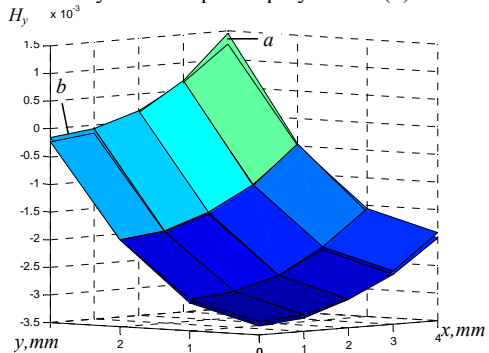

Fig. 5. Single-wire deflection system MF component H_y (a), approximated by 3rd order power polynomial (b)

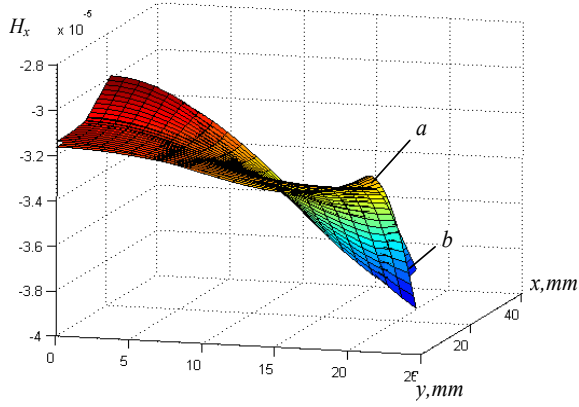

Fig. 6. Base deflection system MF component H_x (a), approximated by 5th order power polynomial (b)

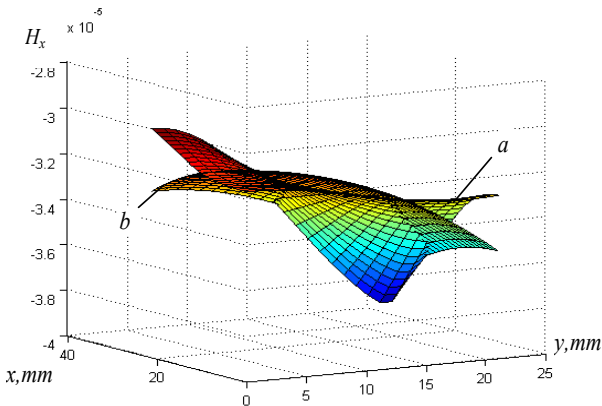

Fig. 7. Base deflection system MF component H_x (a), approximated by 3rd order power polynomial (b)

In Tables 1–2 there are presented single-wire deflection system relative normalized errors at different critical plane points. Table 1 – approximation by 5th order power polynomial; Table 2 – approximation by 3rd order power polynomial. In Tables 3–4 there are presented real deflection system MF component (H_x) approximation errors. Table 3 – approximation by 5th order power polynomial; Table 4 – approximation by 3rd order power polynomial. By analyzing MF approximation errors we can see, that at the farthest magnetic plane points errors can

reach even 8 %. So the question is: what influence will those errors have on electron traces positions on the screen

Table 1. Vertical MF H_y relative normalized errors, %

y \ x	0	1	2	3	4
0	0.1460	0.0974	-0.0291	-0.1492	-0.0565
1	0.0420	0.0173	-0.0450	-0.0841	0.0569
2	-0.1546	-0.1186	-0.0294	0.0854	0.2224
3	-0.0320	-0.0333	0.1748	0.1024	-0.2128

Table 2. Vertical MF H_y relative normalized errors, %

y \ x	0	1	2	3	4
0	2.5494	1.8865	0.1539	-1.8541	-2.7492
1	1.9025	1.3546	-0.0403	-1.5109	-1.7171
2	0.0677	-0.1459	-0.5680	-0.5132	1.2018
3	-2.5737	-2.3654	-1.2963	0.8678	5.3500

Table 3. Horizontal MF H_x relative normalized errors, %

Y \ x	0	6	12	18	21
0	-0.7813	-0.2814	0.7733	0.4428	-1.7169
6	-0.6289	-0.2589	0.5701	0.4027	-1.3333
12	0.1404	0.0431	-0.0299	-0.0965	0.5942
18	1.0348	0.3384	-0.8283	-0.6013	2.8228
21	0.7651	-0.0968	-1.4084	-0.3647	5.4559

Table 4. Horizontal MF H_x relative normalized errors, %

y \ x	0	6	12	18	21
0	-2.2824	-2.0853	-0.6495	3.9457	7.8556
6	-1.5449	-1.6611	-0.9983	2.8558	6.6062
12	1.1968	0.0623	-1.8223	-0.5860	2.6532
18	6.0821	3.4330	-2.2818	-5.2809	-1.0082
21	8.8692	5.4628	-2.1670	-7.2839	-2.4944

In Fig. 8 traces eight electrons on the screen are shown when MF of real deflection system is interpolated (Fig. 8 at the top) and approximated by 3rd order power polynomials (Fig. 8 at the bottom).

Magnetic field approximation errors influence on electron traces position on the screen is presented in Table 5. Average displacements ($\Delta x_v, \Delta y_v$) and standard deviations ($\sigma_{\Delta x}, \sigma_{\Delta y}$) are calculated for different screen zones – screen side ($X=164$ mm, $Y=0$), top ($X=0$, $Y=164$ mm) and corner ($X=179$ mm, $Y=164$ mm).

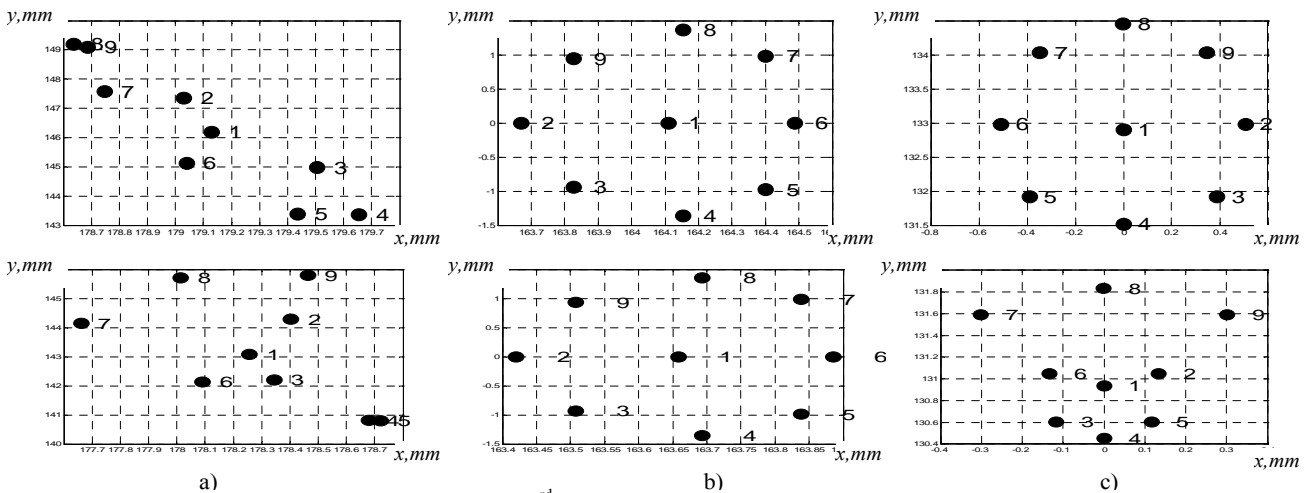

Fig. 8. Base MF interpolation and approximation by 3rd order power polynomial. Electron traces on the screen corner (a), side (b) and bottom (c)

Electron trajectories were calculated by coordinate method using Runge-Kutta 4th-order method for differential equation system solving [3-5].

From presented results we can see, that relative electron traces displacements didn't exceed 0,5% (using 5th order power polynomial) and 3% (using 3rd order power polynomial approximation).

Table 5. Average displacements and standard deviations of electron traces, mm

	X=179 mm, Y=146mm		X=164 mm, Y=0mm		X=0 mm, Y=133 mm	
	5 order	3 order	5 order	3 order	5 order	3 order
Δx_v	-0.0157	-0.8036	-0.0283	-0.4436	0.0158	-0.1538
Δy_v	0.0586	-3.0283	0.0122	-0.0026	0.0222	-1.8900
$\sigma_{\Delta x}$	0.0477	0.2898	0.0222	0.1240	0.0180	0.1656
$\sigma_{\Delta y}$	0.1130	0.3440	0.0103	0.0064	0.1564	0.5577

One electron trajectory calculation time using approximated by 5th order power polynomials MF is approximately the same like using base magnetic field interpolation (2-8 s). Using MF approximation by 3rd order power polynomials calculation speed increases 1.5 times.

Conclusions

In order to get precise electron trajectories, we must have precisely measured or calculated base magnetic field in the nodes of dense grid and use field components linear or cubic interpolation to required point of space.

On purpose to increase electron trajectories calculation speed, MF can be approximated by 5th or even 3rd order power polynomials using polynomial coefficients interpolation by linear or cubic z-functions.

Quite good electron trajectories calculation speed can be achieved by base MF interpolation to required point of space, using linear 3D functions, but for that purpose MF data must be organized to block structure and "running" block modeling structure must be designed.

References

1. Čepulis V. Elektroninė optika. – KTU: Technologija, 2001. – 200 p.
2. Matuliauskas R. The Hybrid Method Determinative Magnetic Fields of DY // Electronics and Electrical Engineering. – Kaunas: Technologija, 2004. – No. 5(54). – P. 15–17.
3. Čepulis V., Navikas D. Modeling of electron trajectories in TV tube // Rigas Tehniskas universitates zinatniskie raksti. 7.Serijs: Telekomunikācijas un elektronika. – Rīga, 2003, Sejums 3. – P. 59–62.
4. Čepulis V., Markevičius V., Navikas D., Tarvydas P., Noreika A., Zabarskas V., Vanagas G. Software package for electronic optical system modeling // ICPR-18: 18th International Conference on Production Research, July 31 - August 4, 2005, Fisciano (SA), Italy: Conference proceedings (Electronic version). – ISBN 88-87030-96-0. – Salerno, 2005. – P. 1–6.
5. Čepulis V., Markevičius V., Navikas D., Tarvydas P. Modeling of TV tube electronic optical system // ITI 2004: Proceedings of the 26th International Conference on Information Technology Interfaces, June 7-10, 2004, Cavtat, Croatia. – ISBN 953-96769-9-1. – P. 513–518.

Submitted for publication 2007 03 28

V. Čepulis, D. Navikas, M. Čepulis. Research of Deflection System Magnetic Field Approximation // Electronics and Electrical Engineering. – Kaunas: Technologija, 2007. – No. 7(79). – P. 33–36.

Approximation of magnetic field of deflection system using power polynomials and approximation influence on electron trajectories modeling accuracy is analyzed here. For investigation analytically calculated single-wire deflection system and measured real deflection system magnetic fields are used. Approximation of these fields by 3rd and 5th order power polynomials is done. Electron trajectories calculation is done using approximated and interpolated magnetic fields. There are presented results of MF approximation and electron trajectories calculation precision analysis. Il. 8, bibl. 5 (in English; summaries in English, Russian and Lithuanian).

В. Чяпулис, Д. Навикас, М. Чяпулис. Исследование аппроксимации магнитного поля системы отклонения // Электроника и электротехника. – Каунас: Технология, 2007. – № 7(79). – С. 33–36.

Анализируется аппроксимация магнитного поля отклоняющей системы степенными рядами и влияние аппроксимации на точность вычисления траекторий электронов. Для исследований использованы аналитически вычисленное магнитное поле однопроводной отклоняющей системы и измеренное магнитное поле реальной отклоняющей системы. Выполнена аппроксимация этих полей рядами 3-ей и 5-ой степени. Вычисления траекторий электронов выполнены используя аппроксимированные и интерполированные магнитные поля. Представлены результаты анализа аппроксимации и точности вычисления траекторий электронов. Ил. 8, библи. 5 (на английском языке; рефераты на английском, русском и литовском яз.).

V. Čepulis, D. Navikas, M. Čepulis. Kreipimo sistemos magnetinio lauko aproksimavimo tyrimas // Elektronika ir elektrotechnika. – Kaunas: Technologija, 2007. – Nr. 7(79). – P. 33–36.

Analizuojamos kreipimo sistemos magnetinio lauko aproksimavimas laipsninėmis eilutėmis ir jo įtaka elektronų trajektorijų modeliavimo tikslumui. Tyrimui panaudoti analitiškai apskaičiuotas vienlaidės kreipimo sistemos ir išmatuotas realios kreipimo sistemos magnetiniai laukai. Atliktas šių laukų aproksimavimas 3 ir 5 laipsnio eilutėmis. Elektronų trajektorijoms apskaičiuoti panaudoti aproksimuoti ir interpoluoti magnetiniai laukai. Pateikti laukų aproksimavimo ir elektronų trajektorijų skaičiavimo tikslumo analizės rezultatai. Il. 8, bibl. 5 (anglų kalba; santraukos anglų, rusų ir lietuvių k.).

DOI: 10.5755/j02.eie.10834