

## **Underactuated Manipulator with Control Based on Variable Dynamic Properties of Joints**

**R. Bansevicius**

*Department of Mechatronics, Kaunas University of Technology,  
Kestucio str. 27, LT-44312 Kaunas, Lithuania, phone: +370 37 30009, e-mail: Bansevicius@cr.ktu.lt*

**K. K. Sarkauskas**

*Department of Control Engineering, Kaunas University of Technology,  
Studentų str. 48-107, LT-51367 Kaunas, Lithuania, phone +370 61025585, e-mail: Kastytis.Sarkauskas@ktu.lt*

**R. T. Tolocka**

*Department of Engineering Mechanics, Kaunas University of Technology,  
Mickeviciaus str. 37 - 118, LT-44244 Kaunas, Lithuania, phone: +370 37 323199; e-mail: Tadas.Tolocka@ktu.lt*

### **Introduction**

Manipulators in which the number of actuators is less than its number of degrees of freedom are called underactuated. They consist of passive and active links and the whole system is controlled by controlling the motion of only active ones. The passive links are equipped with brakes, joining them with active ones. When the brakes are engaged, the passive links are moving together with active links, and when the brakes are released, the passive links move freely. The design of underactuated manipulators differs in terms of braking links and their control. All the known designs have on/off friction brakes, which cannot influence the free motion of the passive links. The underactuated manipulator is a highly nonlinear and needs special control methods, and although research in this field is being carried out intensively, it still remains challenging.

When all the passive links joints are locked, only active joints are considered, and the manipulator is controlled as fully actuated. All possible control strategies of the manipulator in an underactuated state utilize dynamic coupling between passive and active joints exploiting various control schemes devised to drive the passive joints using the available torques at the active ones. The vector of controlled joints may contain both active and passive joints. The position control of the passive links of the manipulator to desired angles via dynamic coupling forces resulting from the torque applied to actuated links was pioneered by research [1,2] on nonholonomic systems. The joints of passive links being controlled and locked in their desired positions, the active links were controlled to position the manipulator and follow a trajectory by point-to-point control. A robust controller using a sliding mode scheme for a passive joint robot is presented in [3]. To avoid exciting high-frequency unmodeled dynamics, the

boundary layer function was used to smooth the discontinuous sliding mode control. However, the use of the boundary layer leads to tracking to within a guaranteed precision rather than perfect tracking. Adaptive robust control for an planar robot was proposed where adaptive control scheme was based on on-line parameter estimation that compensates for parametric uncertainties of the manipulator [4].

The active materials were proposed to switch the joints [5,6,7]. This article presents the design of an underactuated manipulator whose passive link joints are featuring controllable dynamic properties which allow us to extend the passive link motion control possibilities for end-effector positioning and trajectory tracking on the base of active material application. The control scheme of a planar underactuated manipulator is presented and proved by simulation with software CENTAURUS.

### **Active material manipulator joints**

The usual design of an underactuated manipulator includes on/off frictional brakes as link joints. They cannot be applied for passive link free motion control by alternating friction force or damping in the joint. An active material promises this possibility. Piezoactive materials and rheological fluid may be used for it. The piezoactive material application is based on the inverse piezoeffect, which follows the known relationship:

$$S = s^E T + dE, \quad (1)$$

where  $S$  – strain;  $s^E$  – compliance when the electric field is not applied;  $T$  – stress;  $d$  – piezoelectric coupling constant;  $E$  – electric field strength.

By varying the voltage applied, it is possible to control the gap and friction force magnitude in the joint up to full braking and thus influencing motion of the passive link. The friction is controlled by alternating pressure in the link contact when there is no gap at it. The design scheme is shown in Fig. 1, a. If a ring shape piezoelement is used, the following relationships are valid for the ring diameter exchange  $\Delta d_m$  and pressure  $p$  in the contact calculation:

$$\Delta d_m = \frac{d d_m}{h} V, \quad (2)$$

$$p = 2 \frac{Vt}{ghd_0}, \quad (3)$$

where  $d, g$  – piezoelectric constants;  $t$  – piezoelement ring thickness;  $h$  – piezoelement ring height;  $V$  – voltage.

$$d_m = \frac{d_0 + d_i}{2}, \quad (4)$$

where  $d_m$  – piezoelement mean diameter;  $d_0, d_i$  – outer and inner diameters.

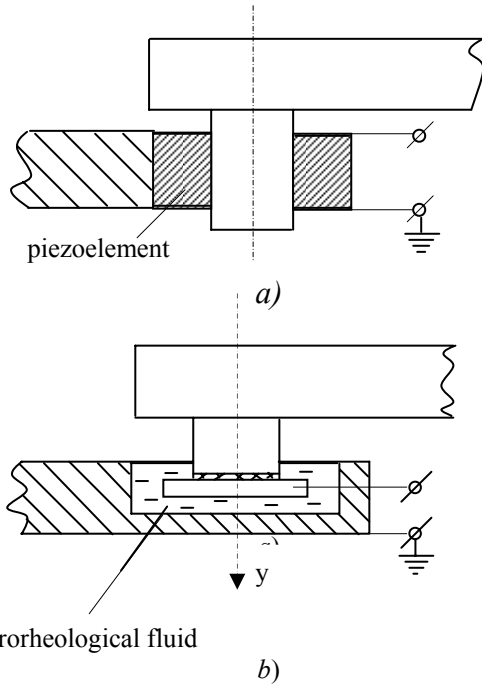

**Fig. 1.** Controllable joints: a – based on piezoelectric material; b – on the base of electrorheological fluid

The rheological fluids are of variable viscosity under the action of the external electric or magnetic field. The first is preferable because it allows us to develop systems with smaller dimensions which is essential for precise manipulators. If the joint gap is filled with electrorheological fluid (Fig.1, b), the following relationship is valid:

$$\sigma = \alpha E^2 + \eta \frac{\partial u}{\partial x \partial t}; \quad (5)$$

where  $\sigma$  – stress in the electrorheological fluid;  $E$  – electric field strength;  $\eta$  – viscosity;  $u$  – displacement of fluid particles;  $t$  – time.

By changing the electric field strength, it is possible to alternate the damping in the joint, thus controlling the passive link motion up to its braking when the field applied is strong enough.

## Underactuated manipulator and its dynamics

An experimental set of the simplest plane underactuated manipulator with active joints is shown in the Fig.2.

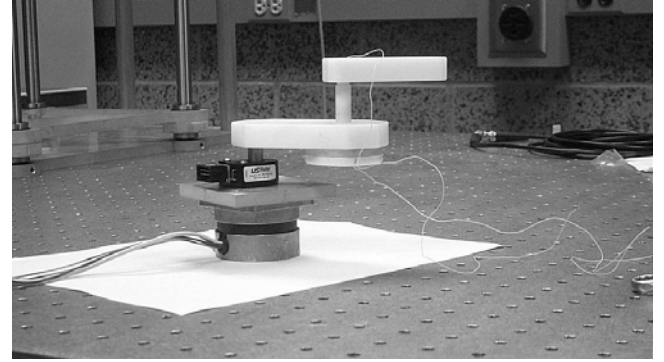

**Fig.2.** Plane underactuated manipulator

The manipulator consists of two movable links, the second of them being passive. The links are joined in between by revolute kinematic pairs  $A$  and  $B$ , where  $B$  is an active material kinematic pair. All the links are equipped by encoders. The motor  $M$  is moving the active link and its torque is controllable.

The dynamics of the manipulator is described by equations

$$\begin{bmatrix} T \\ 0 \end{bmatrix} = \begin{bmatrix} M_{11} & M_{12} \\ M_{21} & M_{22} \end{bmatrix} \begin{bmatrix} \ddot{\theta}_1 \\ \ddot{\theta}_2 \end{bmatrix} + \begin{bmatrix} b \\ -b \end{bmatrix} \begin{bmatrix} 0 \\ \dot{\theta}_2 \end{bmatrix} + \begin{bmatrix} c_1 \\ c_2 \end{bmatrix}; \quad (6)$$

where

$$M_{11} = I_1 + I_2 + m_1 d_1^2 + m_2 l_1^2 + m_2 d_2^2 + 2m_2 l_1 d_2 \cos \theta_2;$$

$$M_{12} = m_2 d_2^2 + I_2 + m_2 l_1 d_2 \cos \theta_2;$$

$$M_{21} = M_{12};$$

$$M_{22} = m_2 d_2^2 + I_2;$$

$$c_1 = -2m_2 l_1 d_2 (\dot{\theta}_1 + \dot{\theta}_2) \dot{\theta}_2 \sin \theta_2 - m_2 l_1 d_2 \dot{\theta}_2^2 \sin \theta_2;$$

$$c_2 = -m_2 l_1 d_2 \dot{\theta}_1 \dot{\theta}_2 \sin \theta_2.$$

Using the second of equations (6) we obtain

$$\begin{aligned} \ddot{\theta}_2 &= f(\ddot{\theta}_1, \dot{\theta}_1, \dot{\theta}_2, \theta_2) = \\ &= \frac{(m_2 d_2^2 + I_2) \ddot{\theta}_1 + m_2 l_1 d_2 \ddot{\theta}_1 \cos \theta_2}{m_2 d_2^2 + I_2} + \\ &= \frac{b \dot{\theta}_2 + m_2 l_1 d_2 \dot{\theta}_1 \dot{\theta}_2 \sin \theta_2}{m_2 d_2^2 + I_2}, \end{aligned} \quad (7)$$

which allows us to organize the underactuated manipulator control applying the first equation of (6) for defining the necessary motor torque  $T$ .

If the case when active material kinematic pair  $B$  is only used to switch the joint between locked/unlocked positions and it is not used for passive link control in free motion, the manipulator is described by system (6) if  $b = 0$ .

In both cases when joint  $B$  is locked, the dynamics of the manipulator is described by system (6), assuming that

$$\ddot{\theta}_2 = \dot{\theta}_2 = 0. \quad (8)$$

### Control of underactuated manipulator

The tracking control of underactuated systems is the question under discussion. There exist many control-techniques for the tracking problem of underactuated systems. The control-techniques, in general, use a local transformation to transform the underactuated mechanical system into the second-order chained form. Then, in general, a globally stable control-technique is applied to this chained form. Due to the local transformation, these controlled systems are only capable of tracking simple paths, such as a line or a circle [8]. With these control-techniques in combination with a local transformation, problems arise when the orientation has to be controlled. It is of interest to study two possible cases of underactuated manipulator control:

- when active material kinematic pairs are only locking/unlocking joint  $B$
- when they are used for passive link free motion control.

The following is related to the first case.

A control strategy to position both joints of an underactuated manipulator was proposed in [8] as:

- control the first joint to the destination regardless of the second joint,
- steer the second joint to the destination by periodic actuation of the first joint.

In the research by the [9] heuristically realized the goal dividing it into two phases:

- Stabilize the second joint onto an invariant manifold passing through the destination,
- Terminate the second joint at the destination in the neighborhood of the destination.

In this section, control methods are developed for frictionless systems analytically using the averaging

method and are applied to practical systems with a little friction. The efficiency of this control method applied to practical systems is shown by experiments.

If the position of the passive joint is controlled according to the desired trajectory, the orientation of the free link also tracks the trajectory, and positioning is achieved. However, both types of trajectory segments are unstable and have an orientation error. Consequently, feedback control is essential to suppress such errors.

A horizontal underactuated manipulator cannot be asymptotically stabilized to any point by any smooth state feedback, based on Brockett's theorem. On the other hand, no state feedback law can stabilize the position and orientation of a free link simultaneously to the desired configuration. Here, exists the problems of the feedback control is changed to stabilize the free link to the desired trajectory or the desired point.

The nonlinear feedback control we used is based on the following idea. In the case of a translational trajectory, the acceleration of the passive joint in the direction of the desired trajectory gives rise to the inertial force on the free link in the opposite direction. Then the link has the same dynamics as a pendulum or an inverted pendulum in a virtual gravity field. Feedback to stabilize the orientation and position of the link to the desired trajectory can be designed using the acceleration normal to the desired trajectory as the input.

Feedback control is based on a dual technique, where the tracking error dynamics are treated as two separate subsystems. A tracking or positioning controller is developed to avoid the desired trajectories caused by the separated or common coordinate transformation.

A lot of research has been conducted on the control of such systems without considering friction at free joints. In this paper, we analyze the behavior of underactuated manipulators with friction at free joints and also controllable friction force by using electrorheological fluid. We also propose a control method to stabilize it for systems with friction. The effectiveness of the method is verified by experiments by schematic shown in Fig. 3.

Simulation of the underactuated manipulator controlled according to the desired trajectory with initial phase of modeling is shown in Fig. 4.

Simulation was provided with software CENTAURUS, usable for modeling of hybrid non-linear systems.

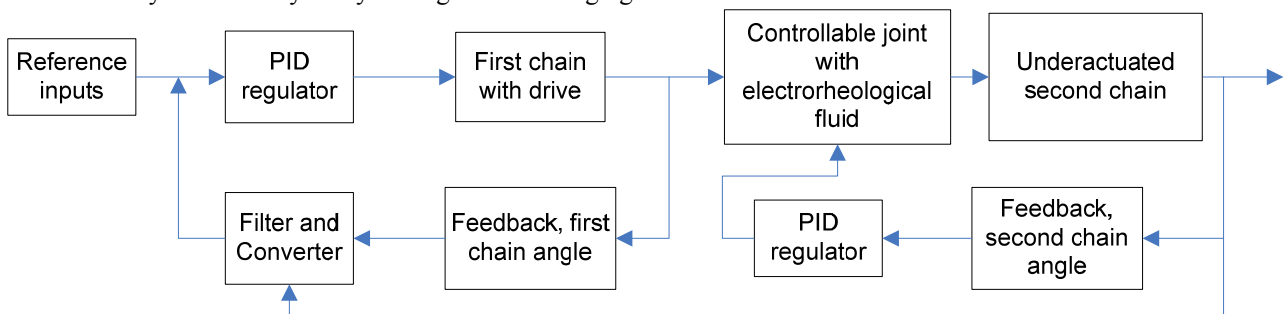

Fig. 3. Control scheme of underactuated manipulator

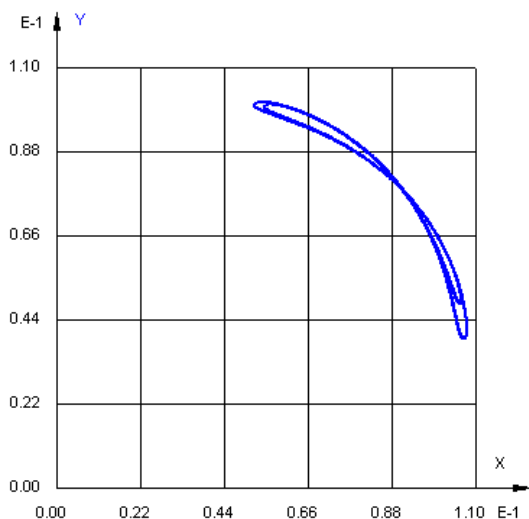

Fig. 4. Control of underactuated manipulator with electrorheological fluid in free joint

## References

1. Arai H., Tachi S. Position Control of a Manipulator with Passive Joints using Dynamic Coupling // IEEE Trans. On Robotics and Automation. – 1991. – Vol. 7. – P. 528 – 534.
2. Arai H., Tanie K., Tachi S. Dynamic Control of a Manipulator with Passive Joints in Operational Space //

- IEEE Trans. On Robotics and Automation. – 1993. – Vol. 1. – P. 85 – 93.
3. Ro P.I., Yih C.C. Robust Control of Passive Jointed Robot and Experimental Validation Using Sliding Mode // Journal of Guidance, Control and Dynamics. – 1996. – Vol.24, No 1. – P. 1039 – 1046.
4. Shin J. H., Lee J. J. Singularity Free Cartesian Path Planning and Adaptive Robust Control of a Robot Manipulator with Swinging Passive Joints. // Systems Science. – 1996. – Vol. 24. No. 1. – P. 73 – 93.
5. Bansevicius R., Fallahi B., Tolocka R. T., Varnavicius V. Smart Underactuated Manipulator: design and dynamics simulation. // Mechanika – 2003. No. 6(38) – P. 24–27.
6. Ragulskis K., Bansevicius R., Kulvietis G. Vibromotors for Precision Microrobots. Hemisphere Publ.Co., N.Y.,1988. – P. 312.
7. Athinayayanan R., Fallahi B., Bansevicius R. Design and Control of Precise Robots with Active Multi-Degree of Freedom Kinematic Pairs // Mechanika. – 2001. No. 1(27) – P. 27–32.
8. Jiang Z. P., Nijmeijer H., A Recursive Technique for Tracking Control of Nonholonomic Systems in Chained Form, // IEEE Transactions on Automatic Control, Vol. 44. No. 2. 1999. – P. 265–279.
9. Nakamura Y., Suzuki T., Koinuma M. Non-linear behavior and control of a nonholonomic free-joint manipulator. // IEEE Trans. on Robotics and Automation, No 13(6), December 1997. – P. 853 – 862.

Submitted for publication 2007 04 16

## R. Bansevicius, K. K. Sarkauskas, R. T. Tolocka. Underactuated Manipulator with Control Based on Variable Dynamic Properties of Joints // Electronics and Electrical Engineering. – Kaunas: Technologija, 2007. – No. 7(79) – P. 3–6.

The underactuated manipulators are ones which have more degrees of freedom than the number of actuators. They allow us to develop the simplest devices with reduced weight, cost and energy consumption. Challenge is in organizing the control of kinematic chain consisting of both passive and active links. This is achieved by utilizing the effect of dynamic coupling in the system. The underactuated manipulator with active materials (piezoactive material, electrorheological fluid) joints between active and passive links is proposed. This offers to use such joints for braking passive links and influencing their free motion. The control of such underactuated manipulator may be organized by PID controller application. Ill. 4, bibl. 9 (in English; summaries in English, Russian and Lithuanian).

## P. Бансевичюс, К. К. Шаркаускас, Р. Т. Толочка. Манипулятор с избыточным числом степеней свободы, управляемый изменением управляемых параметров кинематических пар // Электроника и электротехника. – Каунас: Технология, 2007. – № 7(79). – С. 3–6.

Манипуляторы, которые имеют больше степеней свободы, чем актуаторов, называются манипуляторами с избыточным числом степеней свободы. Они отличаются простотой, малым весом, более низкой ценой и сниженным расходом электроэнергии. Управление таких манипуляторов, состоящих из активных и пассивных звеньев, осуществляется, используя динамические свойства движущихся звеньев. В статье предложено в таких манипуляторах использовать кинематические пары с активными веществами – пьезоактивными материалами, электрореологической жидкостью. Такие кинематические пары позволяют не только соединять пассивные звенья с активными, но и управлять свободным движением пассивных звеньев. Управление таких манипуляторов является сложным, так как регуляторам исполняющих приводов активных кинематических пар сигналов обратной связи приходится синтезировать из сигналов нескольких сенсоров измеряющих положения разных кинематических пар. Желаемое управление наиболее эффективно удается достичь используя ПИД-регуляторы. Ил. 4, библ. 9 (на английском языке; рефераты на английском, русском и литовском яз.).

## R. Bansevicius, K. K. Šarkauskas, R. T. Tolocka. Manipuliatorius su pertekliniu laisvės laipsnių skaičiumi, valdomas naudojant valdomų parametrų kinematinės poras // Elektronika ir elektrotechnika. – Kaunas: Technologija, 2007. – Nr. 7(79). – P. 3–6.

Manipuliatoriai, kurie turi daugiau laisvės laipsnių nei vykdyklių, yra vadinami manipuliatoriais su pertekliniu laisvės laipsnių skaičiumi. Jie išsiskiria paprastumu, mažesniu svoriu, kaina ir energijos suvartojimu. Tačiau tokių manipuliatorių, sudarytų iš pasyviųjų ir aktyviųjų grandžių, valdymas yra organizuojamas panaudojant judančių grandžių dinamines savybes. Straipsnyje siūloma tokiems manipuliatoriams naudoti kinematinės poras su aktyviosiomis medžiagomis – pjezoaktyviosiomis, elektoreologiniu skysčiu. Tokios kinematinės poros gali ne tik sujungti (atjungti) pasyviąsias grandis su aktyviosiomis valdyti pasyviųjų grandžių laisvąjį judesį. Tokio manipuliatoriaus valdymas yra sudėtingas, nes aktyviųjų kinematinė porų vykdyklių regulatoriams grįžtamojo ryšio signalą reikia sintezuoti iš kelių padėties sensorių, esančių skirtingose kinematinėse porose, signalų. Valdymą geriausia organizuoti panaudojant PID reguliatorius. Il. 4, bibl. 9 (anglų kalba, santraukos lietuvių, anglų ir rusų k.).

DOI: 10.5755/j02.eie.10827