

Features of Biotronics Systems

N. Bagdanavičius, P. Balaišis, D. Eidukas, E. Keras, A. Valinevičius

*Department of Electronics Engineering, Kaunas University of Technology,
Studentų str. 50, LT-51368, Kaunas, Lithuania, tel. +370 37 300520, e-mail: eugkera@stud.ktu.lt*

Concept of biotronics

With spontaneous development of electronic technology (ET) it persistently integrates with many human spheres of activity. At the present time the design of infotechnologies, nanotechnologies and biotechnologies is often most promising [1]. All these technologies are under rapid development, using ET, newest their formations and practically inexhaustible possibilities of its processes. ET becomes the tool for cognition and management/control. With its help new phenomenons are found, new features of various objects are investigated as a complex; control of features (processes) is performed. When solving various tasks and problems of human activities, ET operates in junction with other (e.g. biologic) objects. ET helps to gather knowledge about biologic objects (BO), to utilize their functions, to apply the peculiarities of the structures and operation processes of these objects in order to improve electronic devices (ED) and to create efficient biologic process control systems.

At the present time two parallel directions of biology and electronics are developed most intensively – bionics and biotronics.

Biotronics (BT) – the link (interaction) between biologic and electronic objects.

BT system (BTS) is an interaction between biologic (BS) and electronic (ES) systems.

Biotronical, biomechanical, biochemical and other systems form the biotechnical systems, which are the entirities of interconnected and interdependent biological and technical systems or objects, which maintain optimal conditions for investigation and activity of biocomplexes.

BT objects

At the present time the development of biology science has autonomous character. It is separated from electronics in theoretical (not engineering) point of view. Features of biologic objects (processes) are researched, their quality indexes are selected. Biologic systems are investigated in autonomous manner, although ET is used for that purpose. ET (ES) have individual quality (efficiency) indexes. When applying them, the features of these measures are optimized and there are controlled. But

the lack of systemic method does not allow to investigate and optimize (control) the efficiency of interaction between BS and ES. Therefore the purpose of BT is to create the methodology of systemic BTS research and control.

That would render opportunities to register and investigate new features of plants, apply them (in the way of decomposing) for analysis of integral impact of factors on the plants and for improvement of control (using electronic measures).

Therefore main objects of BT theory are: electronical bioanalysis and bioelectronical monitoring.

The following are attributed to the first object: electronical biosensorics; electronical biometry; electronical bio-simulation; modeling of bioelectronics; bioelectronical experiment; etc.

Investigations (registrations, measurements and modeling) of biological features (bioelectronical potentials, potentials of state of rest and operation, biolocation, biodynamics, etc.) are attributed to this direction.

Bioelectronical monitoring based on cybernetics would create opportunities for systemic control of most biologic processes, for their supply and parameters of electronic systems used for that purpose, and at the same time to assure their optimal dynamics (including statistical dynamics).

Interfaces of BS and ES

Generalized diagram of interfaces between BS and ES is presented in Fig. 1. In general case several biologic processes may take place in each BO, which are controlled by respective BS (e.g. $BS_1 - BS_N$). Integrated impact of these processes on the plant is characterized by the set $\{BJ_j\}$ of biologic indicators. Part of known indications are registered by ES receptors ($\{ER_i\}$). Information gathered by these receptors is used by biologic functions control systems ($\{ES_{Fi}\}$), reliability management systems of control measures $\{ES_{Ri}\}$ and control systems ($\{ES_{Ai}\}$) of security measures (SM).

Operation results of BS and ES are registered by integrated BTS (IBTS) [2], which evaluates primary BTS efficiency (considering the reliability of ES and their interfaces with BS), determines the results of reliability

management (estimates secondary efficiency) and efficiency of security measures, and plans development prospects of overall complex by calculating the development efficiency.

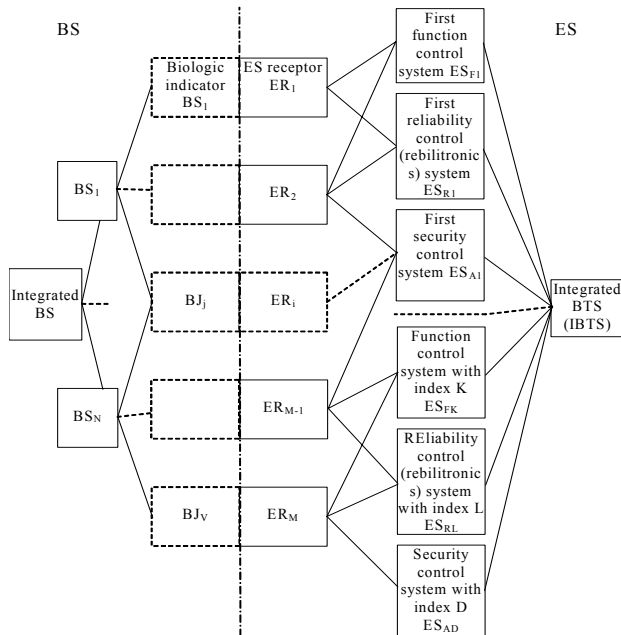

Fig. 1. Interfaces between BS and ES

Main problems during modeling of BS and ES interfaces arise due to the reasons that at the present time BS operation peculiarities are still not fully researched, the influence of these systems on integral impact over plants is difficult to model, some biologic indicators are not known, there is not enough of sensory measures which would provide the operation, reliability and evolution control systems with the necessary information. Most of IBTS operation algorithms are still not developed.

Only when creating the fundamentals of BT it is possible to form united methodology of BS and ES interface analysis and creation. Special attention should be paid to development of techniques and creation of measures of rebitronics and persistence (ability of ES to change itself after a failure and to finish the fulfillment of its tasks).

Efficient (optimal) interface between BS and ES is one of guarantees of successful IBTS operation. IBTS task hierarchy determines the hierarchy of its structure. The first hierarchical level of ES graph immediately control biologic processes, their supply and security. The second level systematizes the control of purpose functions, reliability and persistence. The third level of IBTS controls the evolution (development) of this complex (Fig. 2).

System presented in Fig. 2 provides only main levels of IBTS. Number of them may be much higher. For example, during vegetative reproduction of plants (when planting their sections), it is purposeful to maintain soil temperature higher than of the air above in initial period. Later the ratio of these temperatures is changed. In general case several different levels of soil ($\{H_{gi}\}$) and air ($\{H_{oi}\}$) may be present with different temperatures (Fig. 3). This fact would force to form more BTS control levels of the

first level. That will determine higher number of sensory measures, information flows and control loops.

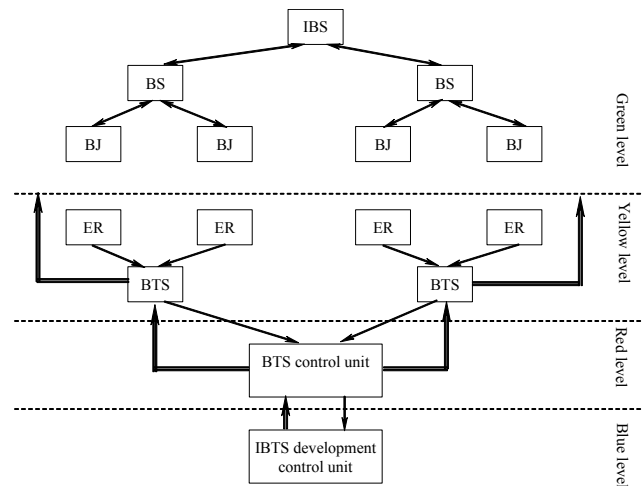

Fig. 2. Hierarchical IBTS levels

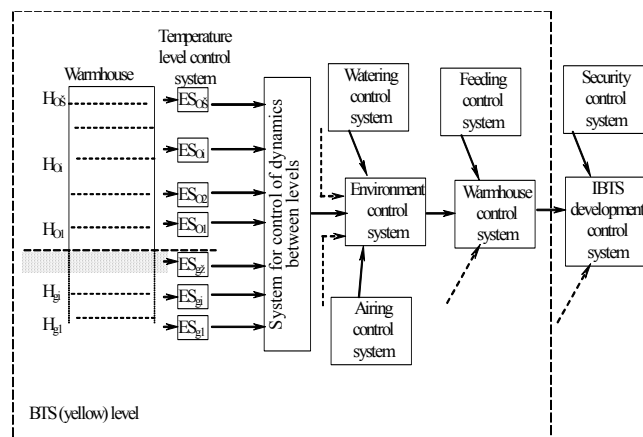

Fig. 3. BTS composition

BT problems

Considering the features of classification all BT problems could be divided into various groups. Perhaps it would be purposeful to distinguish scientific, technical, economical, ecological and other problems. When creating BT theory most actual problems and their groups will vary constantly.

At the present time one of main scientific problems are the following:

1. Due to the lack of electronic research tools there is still little knowledge of plant features. Only sometimes publications on plant energetics, astronomical impacts, Earth energetic fields and impacts of other factors on plants appear. It would be possible to improve the control (monitoring) of biologic processes and uphold biocybernetics with the help of electronic measures, after in-depth analysis of biokinetics, biocontactics, biomagnetics, bioinductin, bioemission, biologic memory and many other phenomenons.

2. A problem of selection and complementation of informative indications of BO state is also still not solved.

3. Methods are not always known how to notice and register these indications. It is not enough to create

sensors and methods of biometry, which provide opportunities to design efficient databases containing information about BO state.

4. Since influence of most factors on BO is integral, thus in order to cognize the object of the research the methods of impact consequence disintegration and systemic investigations should be applied, which are still not created at the present time and this fact limits the opportunities to apply ED (e.g. personal computer) in BT systems.

5. There is still a lack of systemic and statistical biodynamics modeling, systemic biomonitoring and other techniques.

Out of many technical BT problems some of them could be noted:

1. There is a lack of investigations of technical BO features and registration measures.
2. Most of BO state control algorithms and programs are still not created.
3. In order to alleviate the control of BO, it would be purposeful to form a centralized base of information, methods, algorithms and programs. Yet it is not clear, what should be contained in it, where it should be created and how to create it.

One of the main economical problems of BT development is the need for he investments in order to accomplish these works. One BTS user is not capable of providing such investments. Thus it would be necessary to form an IBTS vision and organize centralized research and development of measures.

Ecological BT problems are only a part of all ecological problems in the planet, country or region. But also specific BT problems exist. These are:

1. Protection from undesirable BO propagation from the zone of application into environment.
2. Ecological foods manufacture problems.
3. With estimation of incompletely forecasted consequences it could be expected that undesirable ecological consequences would arise and it could be necessary to adjust the control of BO or even to return back to the traditional manufacture. Therefore during creation of IBTS a problem of fast (with least damage) return to the tradition manufacture. For that purpose IBTS should be designed using modular components, which could be possible to utilize in other activities. Unified technology development policy (methodology, models) is required for this.

Features of biotronics systems

Biotronics systems (BTS) – a very wide complex of systems of various sizes and features, which spans the elementary determined structures and behavior (simple), complex and even very complex [3] systems.

Each class of them can be characterized by different peculiarities (Fig. 4). With increase of BTS level and during creation of integrated BTS (IBTS), their new features constantly emerge. For example, if such features as feedback loops and reliability dominate in the simple systems, complex systems in turn have up to ten or more different features.

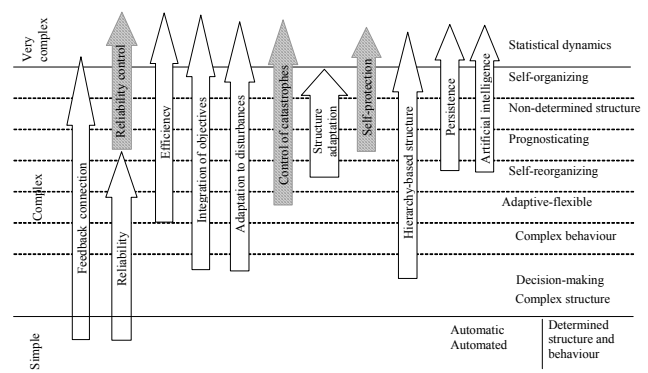

Fig. 4. BTS peculiarities

Beside features, which provide implementation of BTS purpose functions, other group of features emerges, which protects IBTS from various unforeseen impacts, situations (states), and various catastrophes among them. IBTS features of this group are indicated in Fig. 4 by arrows painted in gray. Each of these features emerges in systems of different level and remains during development and integration of these systems into higher-level formations.

The degree by which such IBTS satisfies needs is described by their general efficiency $(E_{\Sigma}(t))$, which consists of primary $(E^{(I)}(t))$, secondary $(E^{(II)}(t))$ and evolution $(E^{(R)}(t))$ efficiencies. $(E^{(I)}(t))$ characterizes the efficiency of performance of main IBTS functions, when no security measures are provided; $(E^{(II)}(t))$ characterizes security efficiency provided by these measures; $(E^{(R)}(t))$ characterizes IBTS operation efficiency evolution in time, with accumulation of experience and statistical data (with self-learning). It is obvious, that

$$E_{\Sigma}(t) = f_E(E^{(I)}(t), E^{(II)}(t), E^{(R)}(t)); \quad (1)$$

here $f_E(\cdot)$ – function of influence of primary, secondary and evolution efficiencies on general efficiency. Average, general IBTS efficiency over time period $t_1 \div t_2$

$$\bar{E}_{\Sigma}(t_1 \div t_2) = \frac{\int_{t_1}^{t_2} \sum_{j=1}^{N_F} \gamma_j [1 - (1 - E_j^{(I)}(t))(1 - E_j^{(II)}(t))(1 - E_j^{(R)}(t))] dt}{t_2 - t_1}; \quad (2)$$

here γ_j – significance coefficient of j -function of IBTS; N_F – number of IBTS functions; $(E_j^{(I)}(t))$, $(E_j^{(II)}(t))$ and $(E_j^{(R)}(t))$ – primary, secondary and evolution efficiencies of implementation of j -function. $(E_j^{(I)}(t))$ is defined as:

$$E_j^{(I)}(t) = \prod_{s=1}^{N_{jp}} e^{-\lambda_{js} \cdot t}; \quad (3)$$

here λ_{js} –intensity of disturbances of s -measure (electronic device, program, operator, ...), which determines the implementation of j -function; N_{jp} –

number of measures determining the implementation of j -function. $(E_j^{(II)}(t))$ is defined as:

$$E_j^{(II)}(t) = f_R(\{R_i(t)\}, \{\Omega_i(t)\}, t); \quad (4)$$

here $f_R(\cdot)$ – the function of influence of reliability control (rebitronics) and persistence [4] providing measures index values $(\{R_i(t)\})$ and $(\{\Omega_i(t)\})$ on the secondary IBTS efficiency.

Rebitronics involves state monitoring, prognostication and correction procedures of IBTS measures, which render opportunities to foresee possible disturbances (disorders) and to avoid them. The structures of controlled reliability IBTS and control complex [5] are presented in Fig. 5 and Fig. 6.

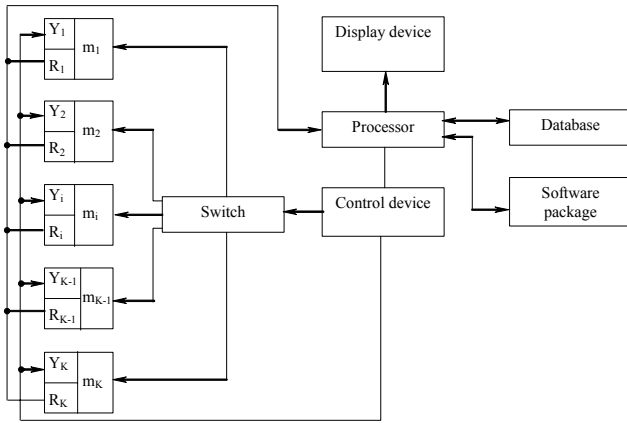

Fig. 5. The structure of controlled reliability IBTS: Y_1 - Y_k – control devices; R_1 - R_k – sensor devices; m_1 - m_k – IBTS components

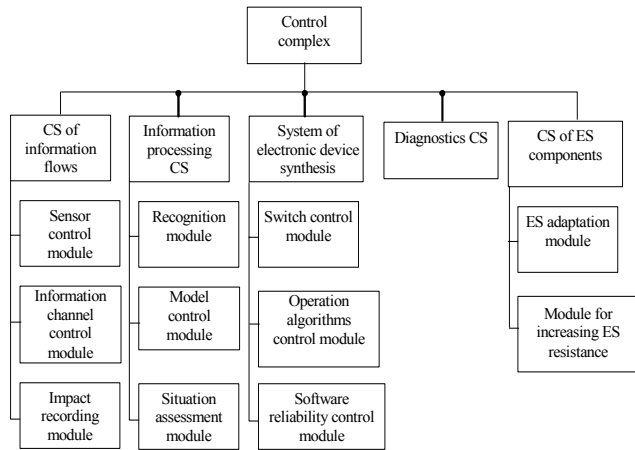

Fig. 6. The structure of IBTS reliability control complex

Specific peculiarities are characteristic to the entirety of reliability control measures of each IBTS network art, but still the main components remain the same.

The set of indexes $\{\Omega_i(t)\}$ was discussed in [4], and artificial intelligence and its influence on the development of the efficiency – [2].

The efficiency of IBTS network explored [6]. There is still very little research done in the field of purpose of IBTS (their network) security measures, their composition and influence on the network efficiency.

Purpose and composition of IBTS security measures

IBTS security measures (SM) can be defined as the entirety of technical, programming and organizational measures, which are intended to protect IBTS from unexpected operation situations, unauthorized actions from outside and undesirable operation impacts on the environment. Since network consists of systems of several hierarchical levels $(\{ES_i\}, \{BTS_i\}, \{IBTS_i\}$ bei $\{IBTS_{Ci}\})$, they perform different level functions and operate in relatively big area and that conditionally or entirely autonomously influence their SM (Fig. 7).

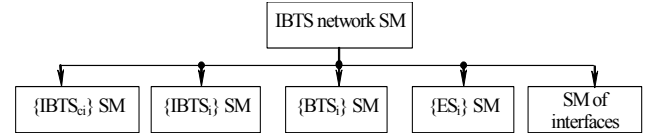

Fig. 7. SM of different IBTS levels

Elements of the arrays $\{ES_i\}$ and $\{BTS_i\}$ in most cases form a complex [2], and $\{IBTS_i\}$ forms a set. Therefore (when interfaces are considered as ideal) general network efficiency in time t :

$$E_T(t) = \sum_{V=1}^{N_C} \alpha_V \cdot E_{CV}(t) \left[\sum_{j=1}^{N_V} \beta_j E_{Ij}(t) \cdot \prod_{i=1}^{N_j} E_{Bi}(t) \cdot E_{Ei}(t) \right]; \quad (5)$$

here $E_{CV}(t)$, $E_{Ij}(t)$, $E_{Bi}(t)$ and $E_{Ei}(t)$ – efficiencies of ν -central, j -integrated, i -biotronic and i -electronic systems in time t ; α_V and β_j – significance coefficients of ν -central and j -integrated systems; N_C , N_V and N_j – numbers of central, integrated and biotronic systems in the network and

$$E_{CV}(t) = E_{CVf}(t) \cdot E_{CVA}(t) \cdot E_{CVR}(t); \quad (6)$$

here $E_{CVf}(t)$, $E_{CVA}(t)$ and $E_{CVR}(t)$ – operation, security and evolution efficiencies of ν -central system. Analogously:

$$E_{Ij}(t) = E_{Ijf}(t) \cdot E_{IjA}(t) \cdot E_{IjR}(t); \quad (7)$$

$$E_{Bi}(t) = E_{Bif}(t) \cdot E_{BiA}(t) \cdot E_{BiR}(t); \quad (8)$$

$$E_{Ei}(t) = E_{Eif}(t) \cdot E_{EiA}(t) \cdot E_{EiR}(t). \quad (9)$$

$E_{CVR}(t)$, $E_{IjR}(t)$, $E_{BiR}(t)$ and $E_{EiR}(t)$ characterize self-learning, experience accumulation and development efficiency respectively. $E_{CVA}(t)$, $E_{IjA}(t)$, $E_{BiA}(t)$ and $E_{EiA}(t)$ is determined by selected electronic SM (ESM), which can have different purposes (Fig. 8).

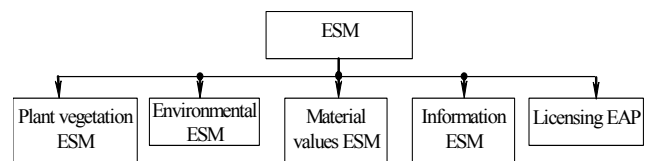

Fig. 8. The composition of ESM

Each group of measures consists of several subgroups (Fig. 9 – 13).

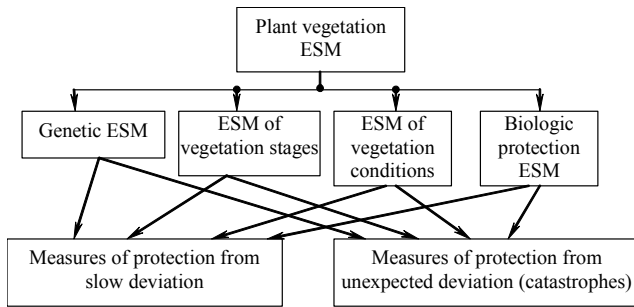

Fig. 9. The composition of plant vegetation ESM

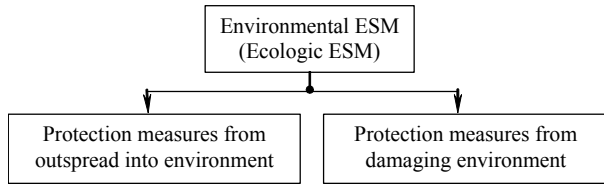

Fig. 10. The composition of environmental ESM

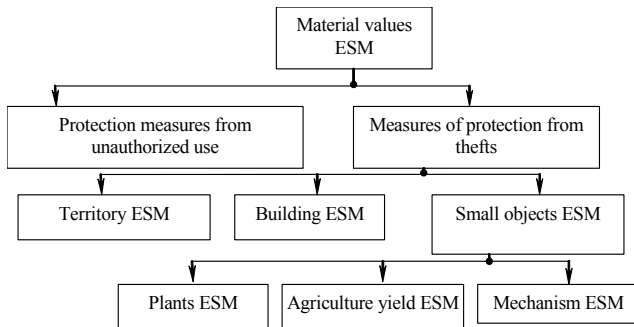

Fig. 11. The composition of material values ESM

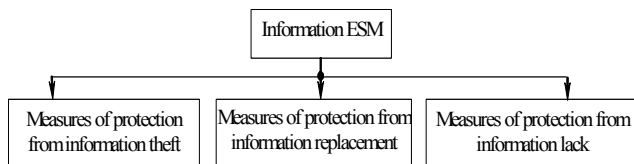

Fig. 12. The composition of information ESM

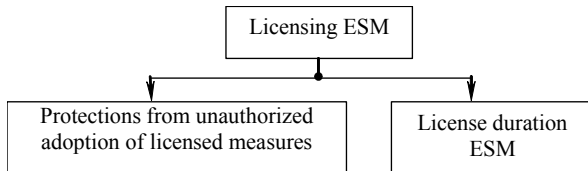

Fig. 13. The license ESM

Measures indicated in Fig. 9 can be further divided into smaller subgroups (Fig. 14 – 16).

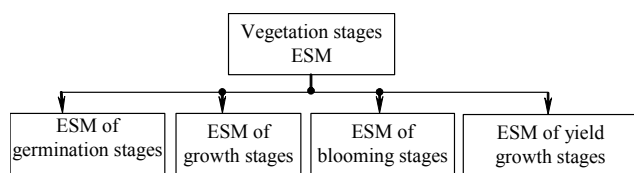

Fig. 14. The composition of ESM of vegetation stages

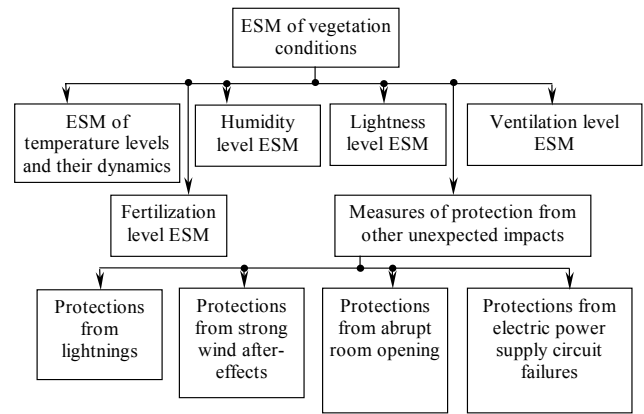

Fig. 15. The composition of ESM of vegetation conditions

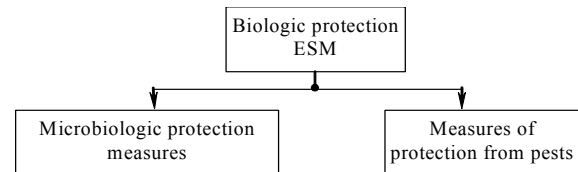

Fig. 16. The composition of ESM of biologic protection

For protection of material values, information and licenses it is possible to use earlier created electronic measures, which are widely applied in car, room and other object security systems. Electronic chips would be most suitable for mentioned security measures in IBTS network. They could be installed on the operator's clothes. But in such case problems could arise when changing the outfit. It would be harder to protect it from unauthorized access. The armband (placed on the hand) would be most convenient, and it would be suitable for protection of rooms, control measures and other objects.

Conclusions

It is obvious from presented material, that one of possible ways to conduct biologic activity in Lithuania could be establishment of countryside business objects which use BT technology.

Efficient BTS operation could be maintained by integral network of territorial, regional or country systems. Modern computer technologies, internet and other measures can be used to automate it.

IBTS network establishment is a complex and expensive process. Thus during its creation it is needed to join the efforts of specialists of various fields: biology, electronics, information science, and others.

During development of biotronics systems and their networks, their new features are inevitably formed, which determine the need to create new dynamical efficiency statistical evaluation methods.

In order to perform comprehensive general IBTS efficiency it is required to assess interactions of many SM, their operation efficiencies and other peculiarities.

References

1. Patrick D., O'Connor T. Practical Reliability Engineering. Fourth Edition. – Stevenage, UK, 2002. – 540 p.

2. **Balaišis P., Eidukas D., Valinevičius A., Žilys M.** Informacinių elektroninių sistemų efektyvumas. – Kaunas: Technologija, 2004. – 358p.
3. **Balaišis P., Eidukas D., Valinevičius A., Žilys M.** Reliability and Efficiency of Electronic Systems. – Kaunas: Technologija, 2006. – 280 p.
4. **Balaišis P., Eidukas D., Navikas D., Vilutis G.** Persistence of Electronic Devices // Modern Problems of Radio Engineering, Telecommunications and Computer Science (Proceedings International Conference TCSET 2002, FEB. 18 – 23, 2002). – Lviv – Slavėko, Ukraine, 2002. – P. 13–15.

5. **Balaišis P., Eidukas D.** Sisteminė elektroninių įtaisų kokybės analizė // Lietuvos mokslas. – 1996. – T.4., Nr. 99. – P. 151-156.
6. **Valinevičius A., Balaišis P., Eidukas D., Bagdanavičius N., Keras E.** Biotronic System Network Efficiency Investigation // Electronics and Electrical Engineering. – Kaunas: Technologija, 2006. – Nr. 3 (67). – P. 13 – 18.

Submitted for publication 2006 10 16

N. Bagdanavičius, P. Balaišis, D. Eidukas, E. Keras, A. Valinevičius. Features of Biotronics Systems // Electronics and Electrical Engineering. – Kaunas: Technologija, 2006. – Nr. 8(72). – P. 55–60.

Peculiarities of biologic object control by electronic measures are investigated. It is pointed out, that it is purposeful to create centralized information supply system for business objects. Conception of biotronics, its vision and principles are formulated. A problem of interfacing biologic and electronic systems is emphasized. Integration principles of biotronic systems are foreseen. Creation conception of integrated biotronic systems (IBTS) is substantiated. IBTS creation problems are distinguished. IBTS efficiency evaluation possibilities are analyzed. Structures of IBTS security implementations are presented. IBTS reliability control complex structure is offered. III. 16, bibl. 6 (in English; summaries in English, Russian and Lithuanian).

Н. Багданавичюс, П. Балайшис, Д. Эйдукас, Э. Кэрас, А. Валиневичюс. Особенности систем биотроники // Электроника и электротехника. – Каунас: Технология, 2006. - № 8(72). С. 55–60.

Исследуются особенности электронного управления биологическими объектами. Показано, что целесообразно создавать централизованную систему обеспечения объектов предпринимательства информацией. Формулируются концепция, понятие и визи биотроники. Акцентируется проблема обеспечения взаимосвязи биологических и электронных систем. Приводятся особенности интегрирования систем биотроники. Обоснована концепция создания сети интегрированных систем биотроники (ИСБТ). Исследуются проблемы создания ИСБТ и их сетей. Анализируются возможности и способы оценки эффективности ИСБТ. Приводятся структуры средств охраны ИСБТ. Предлагаются: структура ИСБТ с управлением надежности и структура средств управления надежностью ИСБТ. Ил. 16, библи. 6 (на английском языке; рефераты на английском, русском и литовском яз.).

N. Bagdanavičius, P. Balaišis, D. Eidukas, E. Keras, A. Valinevičius. Biotronikos sistemų ypatumai // Elektronika ir elektrotechnika. – Kaunas: Technologija, 2006. – Nr. 8(72). – P. 55–60.

Tiriami biologinių objektų elektroninio valdymo ypatumai. Nurodoma, kad tikslinga kurti centralizuotą verslo objektų aprūpinimo informacija sistemą. Formuluojamos biotronikos koncepcija, samprata bei vizijos. Akcentuojama biologinių ir elektroninių sistemų sąsajos problema. Numatomi biotronikos sistemų integravimo ypatumai. Pagrindžiama integruotų biotronikos sistemų (IBTS) tinklo kūrimo koncepcija. Tiriamos IBTS kūrimo problemos. Analizuojamos IBTS efektyvumo vertinimo galimybės. Pateiktos IBTS apsaugos priemonių struktūros. Siūloma IBTS patikimumo valdymo komplekso struktūra. II. 16, bibl. 6 (anglų kalba; santraukos anglų, rusų ir lietuvių kalbomis).

DOI: 10.5755/j02.eie.10789