

Multipositional Colour Picture Tube Test System

V. Augutis, D. Gailius

*Department of Electronic and Measurement Systems, Kaunas University of Technology,
Studentų str. 50-445, LT-51368 Kaunas, Lithuania, tel.: +370 37 45 16 17, e-mail: darius.gailius@ktu.lt*

A. Dumčius

*Department of Electronics Engineering, Kaunas University of Technology,
Studentų str. 50-142, LT-51368 Kaunas, Lithuania, tel.: +370 37 300520, e-mail: antanas.dumcius@ktu.lt*

A. Milinskas, E. Vaičikonis, G. Alekna

SC „Ekranas“, Elektronikos str. 1, Panevėžys, Lithuania, tel.: +370 45 506465, e-mail: alekna@ekranas.lt

Introduction

With increasing video equipment variety the number of types and kinds of manufactured colour picture tubes also increases. Due to rising competition in the market it falls to shorten the time needed to master the technology of new products in all stages: marketing – design – manufacture preparation – tests – introduction to the market. The number of legitimate, production safety, user rights protection (for example, 96/29 Euratom directive concerning ionizing radiation [1]) and other requirements also increases. Tightened requirements were also introduced in the newest edition of standard IEC 60065-2001 „Safety requirements for audio, video and similar purpose electronic devices” [2].

Under the influence of globalization more constructional and technological possibilities appear when designing colour picture tubes, but the competition in the fields of electronic product prices and quality is getting sharper and sharper. In result the providers of various materials and components are often changed, the selection of optimal variant becomes more complex. More and more typical accelerated-type tests are performed in order to receive the results of product reliability and durability.

Minimal duration of typical tests of colour picture tube usage time is 3000 h.

Recently during long-term testing of colour picture tubes normally not less than 12 TV tubes of testing type are examined simultaneously, which are needed in order to receive a defined set of statistical data. If the company produces entire gamut of colour picture tube (CPT) types, then it is required to have a corresponding number of picture tube test positions. Automated TV-tube usage duration test stands [3] are expensive, therefore for the purposes of kinescope parameters variation trends monitoring the simpler construction test stands may be also used.

Picture tube usage duration is related to continuous and discontinuous variations of many parameters. Mathematical model is required in order to forecast the duration according to short-term test results, but the designed model usually is suitable only to one particular picture tube type [4].

Of all continuously degrading parameters the trends of time-variation of anode current and all three cathode currents have the substantial influence on picture tube usage time. The character of anode current variation is mainly determined by R, G and B luminophor degradation over increased usage time. Anode current is measured when constant luminosity and whiteness (9300⁰ K) is present. Modern cathode emission current variation is determined by their construction and the types of materials used. Cathode emission current may even increase over exploitation time [5].

Experiment results

Typical (3000 h) and long-term (18000 h) tests of colour picture tubes were performed. Cathode electric currents variation trends in typical tests are presented in Fig. 1, and in long-term tests – in Fig. 2.

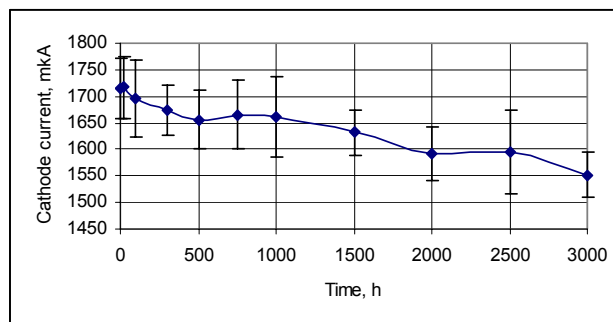

Fig. 1. Variation of electric current of B cathode of A36 type picture tube over time in typical (short-term) tests

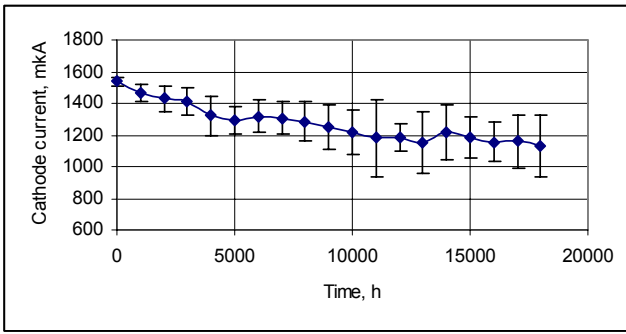

Fig. 2. Variation of electric current of B cathode of A51 type picture tube over time in long-term tests

It is relevant to make prognosis on the basis of typical test results, therefore mathematical expressions were selected using long-term test results, which are most suitable for approximation and forecasting.

Forecasting results and long-term investigation data is presented in Fig. 3.

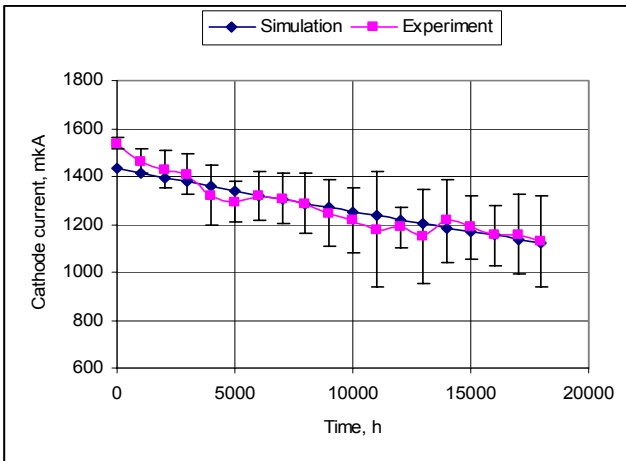

Fig. 3. Variation of electric current of B cathode of A51 type picture tube over time (■- experiment, ◆- simulation)

The following expression was used for approximation:

$$I_{cat} = 1433,75 * EXP(-1,3542 E-5*t), \quad (1)$$

here I_{cat} – cathode current, μA ;
 t – time, h .

Match between experiment and simulation results was checked using Student criterion. It can be stated, that results do not differ statistically ($p = 0.9992$).

Experiment results up to 3000 h and forecasting results up to 18000 h for A36 type picture tube are presented in Fig. 4.

The following expression was used for approximation:

$$I_{cat} = 1700 * EXP(-2,835 E-5*t), \quad (2)$$

here I_{cat} – cathode current, μA

t – time, h .

Match between experiment and simulation results (up to 3000 h) was checked using Student criterion. It can be stated, that results do not differ statistically ($p = 0.9967$).

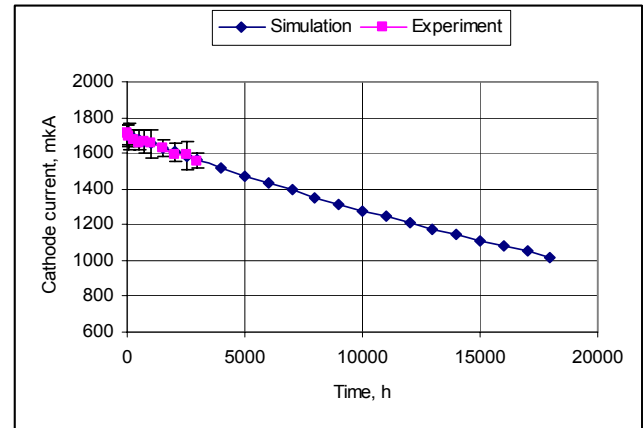

Fig. 4. Variation of electric current of B cathode of A36 type picture tube over time (■- experiment, ◆- simulation)

Analysis of experiment and simulation results has shown that it is possible to select the law of approximation using long-term investigation results. In this case exponential law was most suitable.

In general case the approximation function used in forecasting is

$$I_{cat} = A * exp(-c*t), \quad (3)$$

here c – argument of the function, which is determined from long-term test results;

A – multiplicand, value of which is calculated using short-term results, when cathode current values at 1000, 2000 and 3000 h are approximated linearly.

Approximation function, describing anode current variation in time and suitable for long-term forecasting, is found analogously.

Received investigation results show, that it is possible to forecast picture tube usage time using data of typical tests (up to 3000 h). Certainly, entire range of other factors is not considered here, for example, vacuum degradation, electrode contact failures, shadow-mask deformations and other.

After preliminary assessment of technical and economical aspects by 15 test positions were selected for each CPT type.

The structure scheme of multipositional kinescope test system (MKTS), which has 90 test positions, is shown in Fig. 5.

Kinescopes of types A33, A36, A48, A51 (14"; 16"; 20"; 21") with wide variety of deflection systems, comprising over 20 variants, can be tested in the system.

Kinescope fastening mechanism and stand are installed at each test position, which can be adjusted for any type of kinescope, and also kinescope work mode selection unit is installed there. It can be used to set

nominal values of work mode parameters for these kinescopes: accelerating electrode voltage, anode voltage, heating voltage and electric currents of R, G and B cathodes.

Values of cathode electric currents are indicated during entire test duration, and accelerating and heating voltages – when selecting work mode and during control operations.

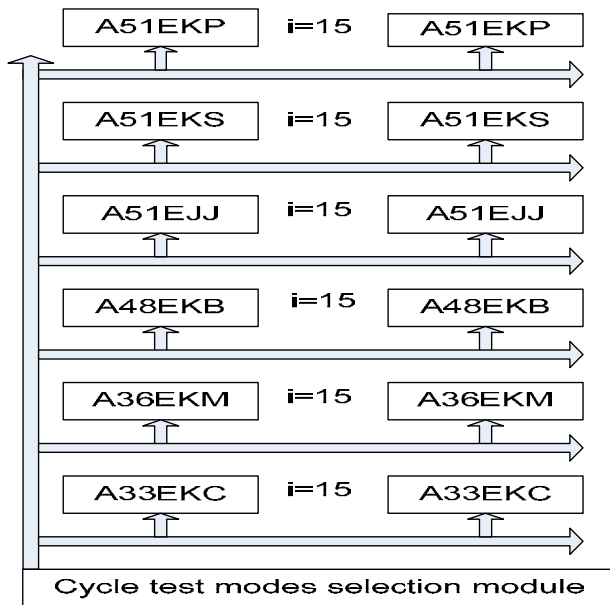

Fig. 5. The structure of multipositional color picture tube test system

The structure of each stand is shown in Fig. 6.

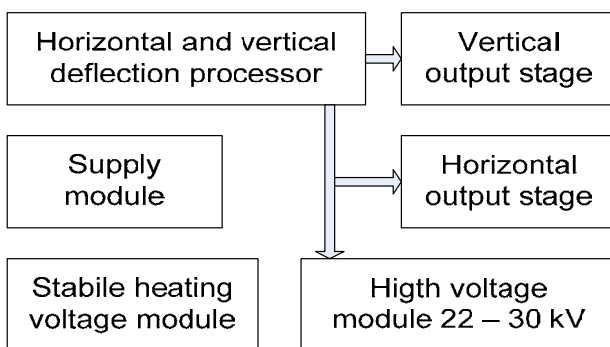

Fig. 6. The structure of testing stand

Heating voltage stabilization is especially relevant when testing kinescopes for usage (exploitation) duration. Cathode operation duration is strongly influenced by its operation temperature, or in other words, the magnitude of heating voltage.

If heating voltage is decreased by 20 percent, if such is possible without breaking the needed electric current mode, the operation duration becomes considerably longer.

Operation in the presence of higher temperature noticeably decreases operation duration of oxide cathode [5].

In the work mode unit of the stand were equipped three separate channels:

- Regulated anode voltage (23 kV to 30 kV) channel;
- Regulated raster size horizontal deflection channel;
- Regulated raster size vertical deflection channel.

Power for these channels is supplied using original power supply unit over voltage pulse converters.

In order to supply power to horizontal deflection channel the voltage from supply unit +103 V is converted by step-down converter to 80 V (it is possible to adjust voltage in the range from 30 V to 102 V), so that it would be possible to receive minimal required raster size in the smallest kinescope; after that it is increased by the second converter step-up converter up to required raster size.

In the anode voltage channel the voltage from + 103 V is increased by voltage pulse step-up converter until the nominal magnitude of the anode voltage U_a is set. After turning on the work mode selection unit the preset nominal anode voltage is always generated when nominal cathode currents are present.

If cathode currents are lower than nominal, e.g. close to zero, and converter output voltage remains the same needed for generation of nominal anode voltage, then anode voltage may substantially exceed the allowable value for kinescopes of this type.

If cathode currents are set to nominal values and converter output voltage is set to receive nominal anode voltage, then anode voltage reaches the nominal magnitude with delay of 10-12 sec.

The vertical deflection channel is supplemented with raster size adjustment measures.

One meter (switch able) of M4N-DV type were used to measure and indicate anode, acceleration and heating voltages, and three meters of M4N-DA type were used to measure and indicate cathode currents. Meters are digital and indicate four significant numbers.

The ranges of set and measured kinescope operation voltages and currents of the work mode units, which are used in MKTS, are listed in Table 1.

Table 1. Voltages and currents measured by MKTS

Measured parameter	Parameter range
R cathode current	(0 – 1000) μ A
G cathode current	(0 – 1000) μ A
B cathode current	(0 – 1000) μ A
Anode voltage	12 – 32 kV
Accelerating electrode voltage	0 – 1500 V
Heating voltage	5 – 10 V

Performed investigations and testing exploitation of created MKTS has shown that technical equipment operates in the limits of prognosticated values of all parameters. Taken technical decisions guarantee the autonomy of each test position, the results of voltage and currents measurements are indicated by digital indicators.

Conclusions

1. It is most purposeful to use the multipositional system in order to investigate the parameters variation trends of multi-type colour picture tubes.

2. Sufficiently good functional flexibility of the system is provided by work mode selection units and module of cycle test mode selection.

3. System can be quickly reconfigured for the test of other type colour picture tube.

References

1. Council Directive 96/26 EURATOM.
2. Audio, Video and Similar Electronic Apparatus - **Safety Requirements** (Adopted CEI/IEC 60065:2001 seventh edition, 2001-12).

Submitted for publication 2006 02 28

V. Augutis, D. Gailius, A. Dumčius, A. Milinskas, E. Vaičikonis, G. Alekna. Multipositional Colour Picture Tube Test System // Elektronika ir elektrotechnika. – Kaunas: Technologija, 2006. – No. 8(72). – P. 35–38.

In this paper the peculiarities of color picture tubes testing system design are considered. The testing system structure and engineering solutions are given. The hardware of modern testing system must be flexible, as it has been indicated by research results. Ill. 6, bibl. 5 (In English; summaries in English, Russian and Lithuanian).

В. Аугутис, Д. Гайлюс, А. Думčius, А. Милинскас, Э. Вайчиконис, Г. Алекна. Многопозиционная система испытания кинескопов // Электроника и электротехника. – Каунас: Технология, 2006. – №. 8(72). – С. 35–38.

Рассматриваются аспекты разработки многопозиционной системы испытания кинескопов. Представлена структура испытательной системы, а также инженерные решения. Показано, что в современных испытательных системах должны быть оборудованы быстро перестраиваемые технические устройства обеспечения. Представлены обобщенные результаты испытания созданной системы. Ил. 6, библи. 5 (на английском языке; рефераты на английском, русском и литовском яз.).

V. Augutis, D. Gailius, A. Dumčius, A. Milinskas, E. Vaičikonis, G. Alekna. Daugelio pozicijų kineskopų bandymų sistema // Elektronika ir elektrotechnika. – Kaunas: Technologija, 2006. – Nr. 8(72). – P. 35–38.

Nagrinėjami kineskopų bandymų sistemos kūrimo aspektai. Pateikta daugelio pozicijų kineskopų bandymo sistemos posistemių struktūra ir inžineriniai sprendimai. Parodyta, kad modernioje bandymo sistemoje turi būti naudojama lanksčiai pritaikoma techninė įranga. Apibendrinti stendo bandymų rezultatai. Il. 6, bibl. 5 (anglų kalba; santraukos anglų, rusų ir lietuvių k.).

3. **Augutis V., Dumčius A., Gailius D., Milinskas A., Alekna G.** Color picture tubes life test bench // Elektronika ir elektrotechnika. – Kaunas: Technologija, 2005. – Nr. 5(61). – P. 89–93.
4. **Valickas J.** Oksidinių katodų fizinio būvio prognozavimo metodikos ir jų taikymas kineskopų gamyboje : disertacija mokslo daktaro laipsniui gauti. – Kaunas: KTU, 1994.
5. **Scheitrum G.** Oxide Cathode Studies. – Prieiga per internetą: <http://www.slac.stanford.edu/grp/kly/muri/murib.htm>.

DOI: 10.5755/j02.eie.10785