

## The Oblique Incidence of the Flat Wave on the Wall with Metallic Lattice Inside

J. Ziemelis, T. Solovjova

Department of Radioelectronic, Faculty of Electronic and Telecommunications, Riga Technical University, Azenes str. 12, LV-1048, Riga, Latvia; e-mails: ziemelis@etf.rtu.lv; solovjova@rsf.rtu.lv

### Introduction

The wave propagation simulation in room requires the mathematical models of walls [1]. Usually for electrically large rooms simulation hybrid methods are applied. These methods simulate ray tracing with reflection between walls of the room. For most cases the incidence of ray on the wall is oblique. The model of homogeneous slab can be obtained analytically by solving simple boundary problem for oblique incidence. Therefore it is tempting to obtain equivalent permittivity for wall with metallic constructions inside. These constructions can be of cylindrical wire, like for reinforced concrete, or flat lattices for electromagnetic securing of room. The boundary problem solving for oblique incidence on the wall with metallic lattice inside allows exploring conditions for which complicated wall can be replaced with complex permittivity.

For most cases the published investigations are dedicated to reinforced concrete for normal incidence of wave [2], [3], [4]. The methods of investigation are different. The published results are obtained for normal incidence and solving methods don't allow apply them like methods for oblique incidence. Usually, metallic structures in composite materials have regular placement that allows applying periodic boundary conditions.

### The structure of block

Slab parameters depend on  $a$  and  $b$  lattice dimensions (see Fig.1.) and dimensions of metallic structure inside slab. The  $a$  and  $b$  are periods of grating along  $x$  and  $y$  axis. The wall contains infinite cluster of blocks like Fig.1. (the dimensions of the wall are considered large enough, comparing with wavelength). At boundary every block is described by periodic boundary conditions, which allow equations solving for one block. The system of Cartesian co-ordinates  $x$  and  $y$  is coupled with center of metallic structure. The sides of lattice  $d_4$  and  $d_5$  show the filling of block cross-section. If  $d_4=d_5=0$ , we have homogenous slab without metallic lattice. If  $d_4 \geq a/2$  or  $d_5 \geq b/2$  we

have two dielectric slabs separated by metallic plate. These two cases don't create periodic structure and can be solved analytically. The periodic structure allows periodic conditions using for all fields' components

$$\begin{cases} f(x+a, y, z) = f(x, y, z) \cdot \exp(-i \cdot k_x \cdot a), \\ f(x, y+b, z) = f(x, y, z) \cdot \exp(-i \cdot k_y \cdot b). \end{cases} \quad (1)$$

The solving of Maxwell's equations for slab of concrete can be decomposed in  $E$  and  $H$  fields with field component along  $z$  axis correspondently.

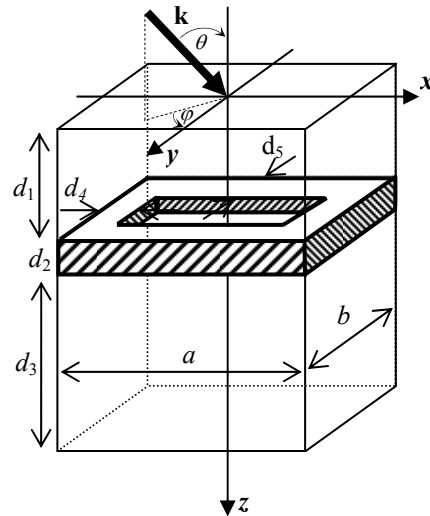

Fig. 1. The structure of block

Let at frequency  $f$  concrete contain permittivity  $\epsilon_c$  and conductivity  $\sigma_c$  [ $S \cdot m^{-1}$ ]. Lattice is created from perfect conductor with thickness  $d_2$ . Complex dielectric permittivity of concrete at frequency  $f$  is

$$\epsilon_c = \epsilon_c - i \cdot \frac{\sigma_c}{2 \cdot \pi \cdot f \cdot \epsilon_0}, \quad (2)$$

wave number

$$k_c = k \cdot \sqrt{\epsilon_c}, \quad (3)$$

where  $k = 2 \cdot \pi \cdot f \cdot \sqrt{\epsilon_0 \cdot \mu_0}$ ;

$\varepsilon_0$  and  $\mu_0$  are permittivity and permeability for free room. For our calculations  $\varepsilon_c = 4.25$  and  $\sigma_c = 0.03$  are selected.

### The field components

On wall incidents flat wave with wave vector

$$\vec{k} = \vec{e}_x \cdot k_x + \vec{e}_y \cdot k_y + \vec{e}_z \cdot k_z, \quad (4)$$

where  $k_x = k \cdot \sin(\theta) \cdot \cos(\varphi)$ ,  $k_y = k \cdot \sin(\theta) \cdot \sin(\varphi)$ ,  $k_z = k \cdot \cos(\theta)$ ,  $k$  – free room wave number,  $\vec{e}_i$  – unit vector.

The wave vector of incident field  $\vec{k}$  can define infinite amount of waves that's vector of polarization lies in perpendicular plane.

For the problem solving field decomposition as  $E$  and  $H$  waves with longitudinal components will be applied  $E_z^{EOI}$  and  $H_z^{HOI}$  correspondently, because metallic structure has periodic placement. For upper index 3 symbols are applied:  $E$  or  $H$  wave type, number that labels environment (0 – for  $z < 0$ , 1 – for  $0 < z < d_1$ , et cetera), third sign  $I$  for wave propagation in direction  $z$ ,  $R$  – opposite direction and  $T$  for denote transversal part of field vector. The last sign \* can indicate complex conjugate value.

The solving of Helmholtz equation for periodic boundary conditions gives admissible values of wave numbers:

$$\left\{ \begin{array}{l} k_{xm} = k_x + \frac{2 \cdot \pi \cdot m}{a}, k_{yn} = k_y + \frac{2 \cdot \pi \cdot n}{b}, \\ k_{imn}^2 = k_{xm}^2 + k_{yn}^2, k_{zmn}^2 = k_0^2 - k_{imn}^2, \\ k_{cmn}^2 = k_c^2 - k_{imn}^2; \\ g_{mn} = \exp(-i \cdot k_{xm} \cdot x - i \cdot k_{yn} \cdot y). \end{array} \right. \quad (5)$$

For designation transversal part  $E$  and  $H$  wave types of electrical and magnetic fields are applied vectors:

$$\left\{ \begin{array}{l} \vec{e}_{Emn} = (-k_{xm} \cdot \vec{e}_x - k_{yn} \cdot \vec{e}_y) / k_{imn}^2, \\ \vec{e}_{Hmn} = (-k_{yn} \cdot \vec{e}_x + k_{xm} \cdot \vec{e}_y) / k_{imn}^2, \\ \vec{h}_{Emn} = (k_{yn} \cdot \vec{e}_x - k_{xm} \cdot \vec{e}_y) / k_{imn}^2, \\ \vec{h}_{Hmn} = (-k_{xm} \cdot \vec{e}_x - k_{yn} \cdot \vec{e}_y) / k_{imn}^2. \end{array} \right. \quad (6)$$

All  $E$  and  $H$  field transversal components can be expressed by the correspondent longitudinal components. Mainly, for boundary conditions will be applied transversal part of field vector. For example, the transversal field of layer 1 is:

$$\begin{aligned} & \sum_{m=-M}^M \sum_{n=-N}^N \left( \vec{E}_{mn}^{E1IT} + \vec{E}_{mn}^{E1RT} + \vec{E}_{mn}^{H1IT} + \vec{E}_{mn}^{H1RT} \right) = \\ & = \sum_{m=-M}^M \sum_{n=-N}^N g_{mn} \cdot \{ \dot{E}_{mn}^{E1I} \cdot k_{cmn} \cdot \vec{e}_{Emn} \cdot \exp(-i \cdot k_{cmn} \cdot z) - \\ & - \dot{E}_{mn}^{E1R} \cdot k_{cmn} \cdot \vec{e}_{Emn} \cdot \exp(i \cdot k_{cmn} \cdot z) + \\ & + \dot{H}_{mn}^{H1I} \cdot \omega \cdot \mu_0 \cdot \vec{e}_{Hmn} \cdot \exp(-i \cdot k_{cmn} \cdot z) + \\ & + \dot{H}_{mn}^{H1R} \cdot \omega \cdot \mu_0 \cdot \vec{e}_{Hmn} \cdot \exp(i \cdot k_{cmn} \cdot z) \}, \end{aligned} \quad (7)$$

$$\begin{aligned} & \sum_{m=-M}^M \sum_{n=-N}^N \left( \vec{H}_{mn}^{E1IT} + \vec{H}_{mn}^{E1RT} + \vec{H}_{mn}^{H1IT} + \vec{H}_{mn}^{H1RT} \right) = \\ & = \sum_{m=-M}^M \sum_{n=-N}^N g_{mn} \cdot \{ \dot{E}_{mn}^{E1I} \cdot \omega \cdot \varepsilon_c \cdot \varepsilon_0 \cdot \vec{h}_{Emn} \cdot \exp(-i \cdot k_{cmn} \cdot z) + \\ & + \dot{E}_{mn}^{E1R} \cdot \omega \cdot \varepsilon_c \cdot \varepsilon_0 \cdot \vec{h}_{Emn} \cdot \exp(i \cdot k_{cmn} \cdot z) + \\ & + \dot{H}_{mn}^{H1I} \cdot k_{cmn} \cdot \vec{h}_{Hmn} \cdot \exp(-i \cdot k_{cmn} \cdot z) - \\ & - \dot{H}_{mn}^{H1R} \cdot k_{cmn} \cdot \vec{h}_{Hmn} \cdot \exp(i \cdot k_{cmn} \cdot z) \}. \end{aligned} \quad (8)$$

The field's intensity for other layers can be written like this.

The significant property of this field representation is orthogonality. If layer is homogenous like  $z < 0$ ,  $z \in [0, d_1]$ ,  $z \in [d_1 + d_2, d_1 + d_2 + d_3]$ ,  $z > d_1 + d_2 + d_3$ , defined field will be integrated over all cross-section of block

$$\begin{aligned} & \int_{-a/2}^{a/2} \int_{-b/2}^{b/2} \left[ \vec{E}_{mn}^{E1IT} \times \vec{h}_{E pq} \right] \cdot \vec{e}_z \cdot g_{pq}^* \cdot dx \cdot dy = \\ & = \begin{cases} \frac{k_{cpq} \cdot a \cdot b}{k_{ipq}^2} \cdot \dot{E}_{pq}^{E1I} \cdot \exp(-i \cdot k_{cpq} \cdot z), m = p, n = q, \\ 0, \text{ otherwise.} \end{cases} \end{aligned} \quad (9)$$

$$\int_{-a/2}^{a/2} \int_{-b/2}^{b/2} \left[ \vec{E}_{mn}^{E1IT} \times \vec{h}_{H pq} \right] \cdot \vec{e}_z \cdot g_{pq}^* \cdot dx \cdot dy = 0. \quad (10)$$

Only layer  $z \in [d_1, d_1 + d_2]$  contains metallic lattice that occupies a part of cross-section and integrating (10) must be cared out only over part of cross-section and orthogonality default. On metallic part of lattice for  $z = d_1$  and  $z = d_1 + d_2$  tangential components of electric field (7) must be zero.

### System of equations

System of equations for solving all the components for  $E$  and  $H$  fields can be created from boundary conditions on all the surfaces of layers. For example at surface of wall ( $z=0$ ) conditions for tangential components electrical fields

$$\begin{aligned} & \vec{E}_{00}^{EOI} + \vec{E}_{00}^{HOI} + \sum_{m=-M}^M \sum_{n=-N}^N \left( \vec{E}_{mn}^{EOR} + \vec{E}_{mn}^{HOR} \right) = \\ & = \sum_{m=-M}^M \sum_{n=-N}^N \left( \vec{E}_{mn}^{E1I} + \vec{E}_{mn}^{E1R} + \vec{E}_{mn}^{H1I} + \vec{E}_{mn}^{H1R} \right) \end{aligned} \quad (11)$$

contain  $E$  and  $H$  wave type and waves with opposite propagation direction. Similarly field conditions for magnetic field and on other surfaces of layers can be written. The balance equation can be multiplied by transversal part of  $E$  and  $H$  wave type vectors and integrated over cross-section occupied by concrete.

The next step for problem solving is a chosen number of wave types taken in to account.  $M$  and  $N$  depend on uniform of layers. The slab without metallic structure can be solved exactly with  $M=N=0$ , but deviation from uniform structure excite other type of waves. The highest types can be propagative or evanescent. The ability to propagate the highest types depends on the block size ( $a$  and  $b$ ),

wavelength ( $\lambda$ ), permittivity and wave incident angles. The  $M$  and  $N$  values must be selected so as all propagative types are taken into consideration or, best of all, that some lower evanescent types are taken in to account. Calculations are carried out for  $M=N=3$ .

### The results of calculation

The results of calculation contain various tables and graphics. For this paper selected incident field H type wave with  $H_z=0.005$  A/m,  $\varphi=0$ . Layers  $d_1=0.05$ ,  $d_2=0.001$ ,  $d_3=0.05$ ,  $a=0.1$ ,  $b=0.15$ . Some results reproduce  $|RE|$  or  $|TE|$  that are module reflection or transmission coefficients for dominant mode.

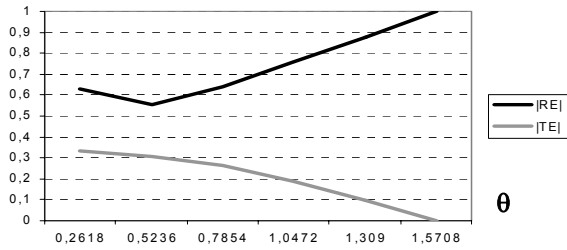

**Fig. 2.** Reflection and transmission coefficients for  $f=1.8$  GHz,  $d_4=d_5=0.02$  m for different incident angles

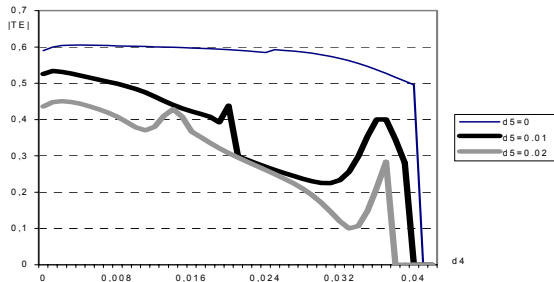

**Fig. 3.** Transmission coefficients for  $f=1.8$  GHz,  $\theta=\pi/6$  for different  $d_4$  and  $d_5$

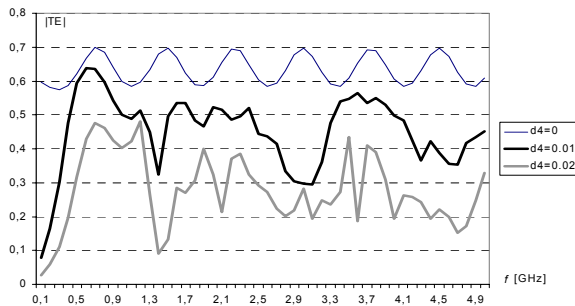

**Fig. 4.** Transmission coefficients at incident angle  $\theta=\pi/6$  for different  $d_4=d_5$

Frequency  $f=1.8$  GHz chosen for graphics because geometric dimensions of lattice in domain  $f \geq 2$  GHz begin create propagative modes with  $m \neq 0$  or  $n \neq 0$ . The inclusion of the highest modes causes dependence the reflected and transmitted fields from co-ordinates in cross-section.

For dominant mode dependence on co-ordinates in cross-section can be characterized by

$$g_{00} = \exp(-i \cdot k_x \cdot x - i \cdot k_y \cdot y). \quad (12)$$

The cover highest modes create near surface the wall difficult field distribution and cross polarization. For  $f=1.8$  GHz,  $\theta=\pi/6$ ,  $d_4=d_5=1$  cm in (Fig. 5., Fig. 6.) reproduced transmitted electric field intensity on surface and on distance 20 cm from surface. The (Fig. 7.) reproduces cross polarization on surface.

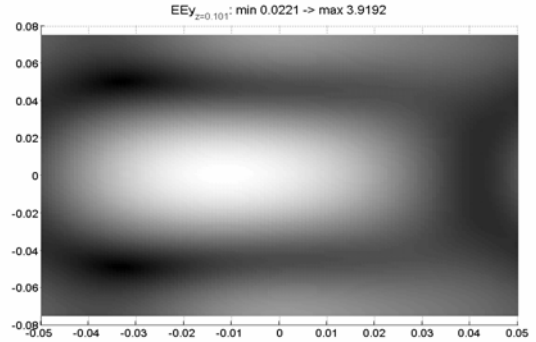

**Fig.5.** Distribution of transmitted field on surface

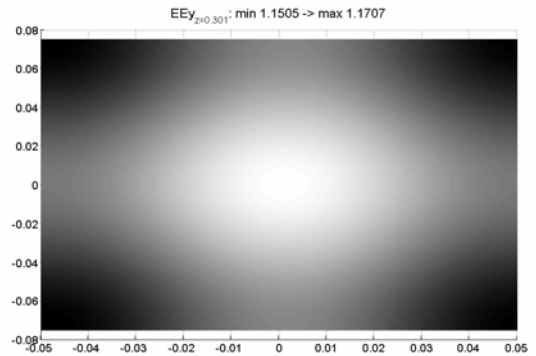

**Fig. 6.** Distribution of transmitted field on distance 20 cm from surface

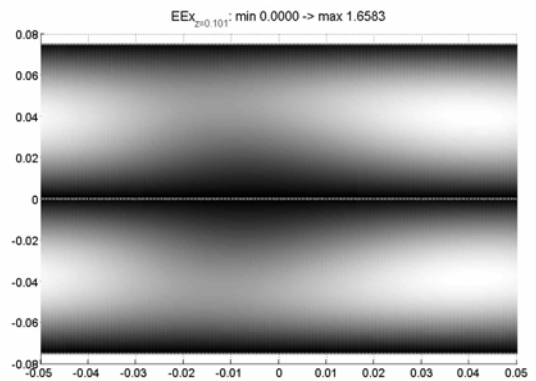

**Fig. 7.** Distribution of cross polarization of transmitted field on surface

As the observation point moves away from surfaces of wall the deflection from field distribution of dominant mode and cross polarization exponential decreases.

### Conclusion

The research reflection and transmission of electromagnetic wave through dielectric slab with metallic

lattice inside was carried out for getting the mathematical model of in case oblique incidence. Solving boundary problem for dielectric structure with metallic lattice inside gets the results. The periodic boundary conditions are implemented by decomposition in TE and TH wave types.

The highest modes create near surface the wall the difficult field distribution and cross polarization. Such field distribution does not permit model without periodic structure inside. Only if geometry structure and wavelength of incident wave allow not arising propagative highest modes, a possibility to create easy mathematical model for far zone observation point exists.



This work has been partly supported by the European Social Fund within the National Programme “Support for the carrying out doctoral study programm’s and post-doctoral researches” project “Support for the development of doctoral studies at Riga Technical University”.

## References

1. **Ziemelis, J.** The Models of Walls for Ray Tracing Indoor Simulation // *Electronics and Electrical Engineering*, ISSN 1392–1215. – Kaunas: Technologija, 2001. – No. 4(32). – P. 20–23.
2. **Wait J. R.** Theory of scattering from wire grid and mesh structures // *Electromagnetic Scattering* – New York: Academic, 1978.
3. **Richalot E., Bonilla M., Wong Man-Fai.** Electromagnetic Propagation into Reinforced-Concrete Walls // *IEEE Transactions on Microwave Theory and Techniques*, 2000. – V. 48, No. 3. – P. 357–366.
4. **Paknys R.** Reflection and Transmission by Reinforced Concrete – Numerical and Asymptotic Analysis // *IEEE Transactions on Antennas and Propagation*, 2003. – V. 51, No. 10. – P. 2852–2861.

Submitted for publication 2006 05 23

**J. Ziemelis, T. Solovjova. The Oblique Incidence of the Flat Wave on the Wall with Metallic Lattice Inside // *Electronics and Electrical Engineering*. – Kaunas: Technologija, 2006. – No. 7(71) – P. 55–58.**

This paper contains findings of authors, which concern reflection and transmission electromagnetic waves in case of oblique incidence for dielectric slab with metallic lattice with periodic structure inside. The reflected and transmitted fields are calculated by solving boundary problem. For solving periodic structure field decomposition in TE and TM wave types is applied. The highest modes create near surface of the wall the complicated field distribution and cross polarization. Such field distribution does not permit model without periodic structure inside. Only if geometry structure and wavelength of incident wave allow not arising propagative highest modes, a possibility to create easy mathematical model for far zone observation point exists. Ill. 7, bibl. 4 (in English; summaries in English, Russian and Lithuanian).

**Ю. Зиемелис, Т. Соловьёва. Наклонное падение плоской волны на диэлектрический слой с периодической металлической решёткой внутри // *Электроника и электротехника*. – Каунас: Технология, 2006. – № 7(71). – С. 55–58.**

Работа содержит исследования отражения и прохождения электромагнитных волн в случае наклонного падения на диэлектрический слой с внутренней металлической периодической решёткой. Отражённое поле и прошедшее поле вычисляются путём решения краевой задачи. Для решения применяется разложение поля периодической структуры на волны типа TE и TM. Волны высшего порядка создают вблизи поверхности стены сложную картину распределения поля и кросс-поляризации. Такое распределение не свойственно моделям без внутренней периодической структуры. Только в случае, если геометрия структуры и длина падающей волны не способствуют возникновению волн высших типов, существует возможность создания простой математической модели для точки наблюдения поля в дальней зоне. Ил. 7, библи. 4 (на английском языке; рефераты на английском, русском и литовском яз.)

**J. Ziemelis, T. Solovjova. Įstrižas plokščiosios bangos kritimas į sieną su vidiniu metaliniu tinkleliu // *Elektronika ir elektrotechnika*. – Kaunas: Technologija, 2006. – Nr. 7(71) – P. 55–58.**

Aprašomi tyrimai, susiję su įstrižai į dielektrinės plokštės, kurios viduje yra periodinio žingsnio tinklelis, paviršių krintančių elektromagnetinių bangų atspindžiu ir praėjimu Atsispindėjusio ir praėjusio lauko parametrai apskaičiuojami sprendžiant ribinių sąlygų uždavinį. Sprendžiant uždavinį pritaikytas lauko išskaidymas į TE ir TM tipų bangas. Aukščiausios bangų modos sienos paviršiuje sukuria sudėtingos struktūros ir skersinės poliarizacijos lauką. Toks lauko pasiskirstymas neleidžia modeliuoti periodinės vidinės struktūros objektų. Nesudėtingą matematinį modelį galima sukurti tik tuo atveju, jei struktūros geometrija ir krintančios bangos ilgis yra tokie, kad aukštesnės bangų modos nėra sukuriamos. Il. 7, bibl. 4 (anglų kalba; santraukos anglų, rusų ir lietuvių k.).

DOI: 10.5755/j02.eie.10773