

Implementation of the Control Algorithm of the Variable Structure Controller in the Electromechanical Servo System

N. Šulčius, V. A. Geleževičius

Department of Control Technology, Kaunas University of Technology,
Studentų str. 48, LT-51367 Kaunas, Lithuania; phone: +370 37 300291, e-mail: n.sulcius@tf.su.lt,
Vilius.Gezelevicius@ktu.lt

Introduction

The special technique of the dynamical quality improvement of an electromechanical servo drive has been proposed and analyzed in the articles [1,2]. The point of this technique is the variable structure velocity controller application. The main peculiarity of such controller is the possibility of its control law automatic change from the proportional integrating (PI) mode to the proportional (P) mode and vice versa during the transient regime of the servo drive. The following algorithm of the controller control law change has been proposed and investigated [2]: in the initial phase of the transient regime of the drive the velocity controller is adjusted according to the PI control law corresponding to the symmetric optimum condition; at the time when the armature current reaches its maximum value, the control law is switched to the P control law corresponding to the quantitative optimum condition; finally, after some delay time the control law is switched again from the P to the PI mode and remains unchanged up to the end of the cycle. This delay time depends on the load of the drive and is to be defined on line during the transient regime. Fuzzy logic control approach for the delay time definition is proposed and the velocity control system with a variable structure controller commanded by a special Fuzzy logic based delay time definition device is investigated in this article.

Structure of electromechanical servo system

The block diagram of the DC electric drive velocity control system with variable structure controller, commanded by the Fuzzy logic delay time definition device, is presented in Fig.1. The control system consists of internal motor current control system, represented by the simplified transfer function of the first order

$$H_{CL}(s) = \frac{k_{CL}}{2T_c s + 1} \quad (1)$$

A mechanical part of the system with transfer function k_M/s , a velocity feedback k_Ω , and a Fuzzy logic based variable structure velocity controller *FLVSC*.

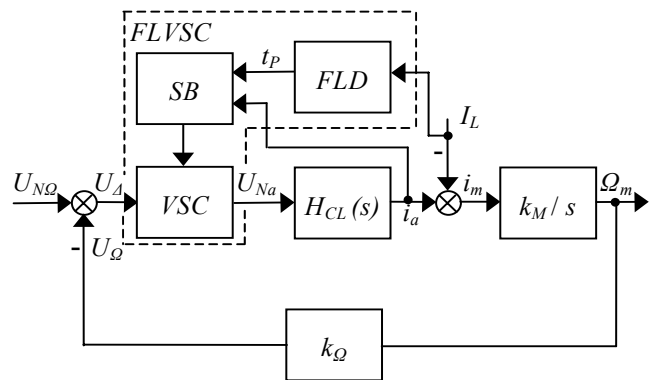

Fig. 1. Block diagram of the velocity control system with Fuzzy logic based variable structure velocity controller *FLVSC*

The main parts of *FLVSC* are the variable structure controller itself *VSC*, able to turn proportional (P) control law

$$H_P(s) = k_{P\Omega} \quad (2)$$

to proportional-integrating (PI) control law

$$H_{PI}(s) = k_{P\Omega} \left(1 + \frac{1}{8T_c s} \right) \quad (3)$$

and vice versa, the control law switching block *SB*, and Fuzzy logic based delay time definition device *FLD*. There in the expressions (1,2,3) the following definitions are applied: $k_{P\Omega}$ denotes a gain of the proportional (P) velocity controller, k_{CL} - a gain of the closed current control loop, T_c - a small time constant of the power converter of the electric drive.

On the base of results obtained in [2], the following control algorithm of the velocity controller control law change is defined: in order to obtain the extreme rapidity

of transient regime in the start phase of the drive (after applying the control signal U_{NO}), the velocity controller switches according to the PI control law. Owing to this, the acceleration of the motor is forced. At the time when the motor armature current reaches its maximum value i_{amax} , velocity controller is turned to the P control law (the integrating channel is disconnected and discharged). After some delay time defined by the Fuzzy logic device FLD , the velocity controller control law is returned again to the PI control law (for steady-state velocity error elimination) and remains unchanged up to the new start of the drive.

Design of Fuzzy logic based delay time definition device

The core of the Fuzzy logic control approach is the fuzzy sets where variables can have different degrees (between 0 and 1) of membership [3]. The architecture of the Fuzzy logic device (FLD) is presented in Fig. 2 [4].

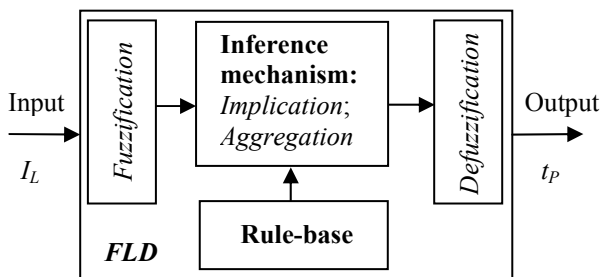

Fig. 2. Architecture of the Fuzzy logic device

The Rule base consists of the list of IF-THEN rules. In our case FLD is a single input-single output (SISO) system (Fig. 2), and an IF-THEN rule assumes the form

$$\text{IF Load is A THEN Delay is B;} \quad (4)$$

where $Load$ is input linguistic variable - the load current I_L with the range $[0 \div I_N]$, $I_N = 1.82A$ is a nominal load current; $Delay$ is output linguistic variable - the proportional (P) control law duration time t_p with the range $[0.01 \div 18.5ms]$; A and B are linguistic values defined by fuzzy sets on the input and output ranges (universes of discourse). The IF-part of the rule is called the *antecedent*, and the THEN-part of the rule is called the *consequent*. Six linguistic values, which correspond to the appropriate membership functions (Fig. 3, 4), have been assigned to the input and output linguistic variables. The Rule base is formed with six linguistic rules:

$$\left\{ \begin{array}{l} \text{IF Load is None THEN Delay is Longest;} \\ \text{IF Load is Very Small THEN Delay is Longer;} \\ \text{IF Load is Small THEN Delay is Long;} \\ \text{IF Load is Very Medium THEN Delay is Medium;} \\ \text{IF Load is Medium THEN Delay is Short;} \\ \text{IF Load is Nominal THEN Delay is Very Short.} \end{array} \right. \quad (5)$$

All rules are evaluated in parallel, and the order of the rules is unimportant. The linguistic rules (5), input-output membership functions (Fig. 3, 4) have been formed manually according to the investigation results [2].

There are four steps of the mapping from the input to the output in the Fuzzy logic device FLD (Fig. 2):

1. *Fuzzification* of the input.

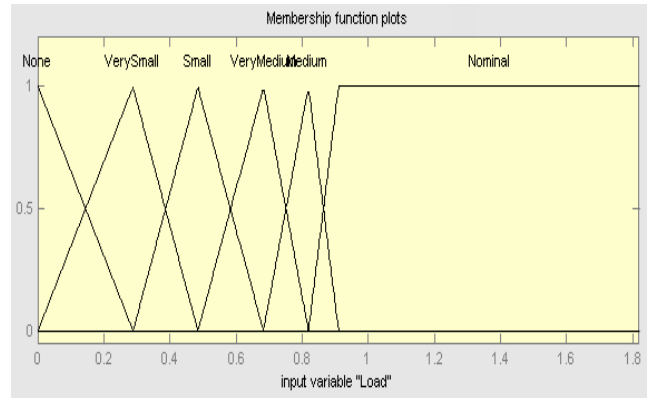

Fig. 3. Membership functions of the input linguistic variable $Load$ in Mamdani-type and Sugeno-type FLD

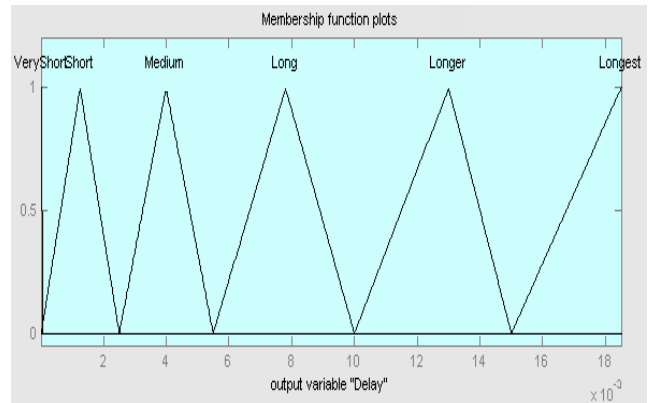

Fig. 4. Membership functions of the output linguistic variable $Delay$ in Mamdani-type FLD

2. *Implication* from the *antecedent* part of the rule to the *consequent*.

3. *Aggregation* of the *consequents* across the rules.

4. *Defuzzification* of the aggregated output fuzzy set.

During the first step - *fuzzification*, the input is taken and determined the degree to which it belongs to each of the appropriate fuzzy set via membership function. Inference mechanism is the reasoning process that determines the aggregated fuzzy output depending on the linguistic rules from the Rule base, and in our case it performs *implication* and *aggregation* functions. The *implication* function modifies fuzzy set to the degree specified by the *antecedent* part of the rule. It was chosen *product* implication method [5], which scales the output fuzzy set. The output fuzzy sets for each rule are then aggregated into a single output fuzzy set. Finally the resulting set is defuzzified (solved) to a single (crisp) value.

Two types of the Fuzzy logic device (FLD) have been designed: Mamdani-type and Sugeno-type [5,6]. These two types of the FLD differ in the way output is determined. In the Mamdani-type FLD , after the *aggregation* process the output membership function of the output variable (Fig. 4) is a fuzzy set. While a Sugeno-type FLD uses a constant value (singleton) as the output membership function (in our case it has six constant values (singletons): 0.01; 1.2; 3; 7; 13; 17 ms). In order to obtain a crisp output value, in Mamdani-type FLD was chosen a center of gravity (COG) [5] defuzzification method

$$y_{oM} = \frac{\int_Y y \mu_a(y) dy}{\int_Y \mu_a(y) dy} ; \quad (6)$$

where y_{oM} - defuzzified (crisp) output value of the Mamdani-type FLD , $\mu_a(y)$ - aggregated membership function, y - output variable, Y - a range of the output variable value. The final (defuzzificated) output of the Sugeno-type FLD was selected as weighted average [5] of all rule outputs

$$y_{oS} = \frac{\sum_{i=1}^N w_i \cdot y_i}{\sum_{i=1}^N w_i} ; \quad (7)$$

where y_i - the output value (singleton) of the i -th rule, w_i - the firing strength (a rule weight) of the i -th rule, N - the number of rules.

The input-output dependence of the Fuzzy logic device - $t_p=f(I_R)=f(I_L/I_N)$ diagram is represented in Fig. 5, where t_p - the duration time of the proportional (P) control law, I_L - the load current, I_N - the nominal load current, I_R - the relative load current (ratio of I_L and I_N currents). Three

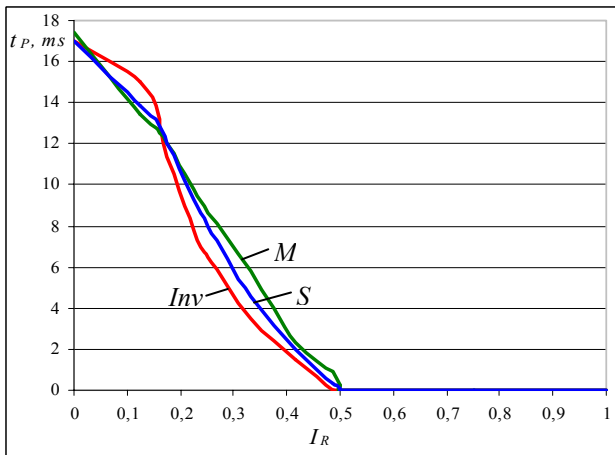

Fig. 5. $t_p=f(I_R)=f(I_L/I_N)$ diagram: input-output dependence of the Fuzzy logic device

curves are presented in this picture: M curve is obtained from the designed Mamdani-type FLD , S curve is obtained from the designed Sugeno-type FLD , Inv curve is obtained from the investigation results [2] and is considered as theoretical curve. In the range $[0.5 \div 1]I_R$ all three curves coincide, while in the range $[0 \div 0.5)I_R$, M and S curves differ a little from Inv curve, but this difference do not have significant influence to the dynamical quality of the electric drive - it remains the optimal (Fig. 6). Consequently both Mamdani-type and Sugeno-type Fuzzy logic devices are suitable for defining the duration time of the P control law.

Simulation results of electromechanical servo system

Simulation was performed using MATLAB package (Fuzzy Logic Toolbox and Simulink) [6]. It was used the fifth-order Dormand-Prince numerical integration method with fixed step size 0.00001.

In Fig. 6 is demonstrated a dynamical quality (defined by the $ITAE$ quality criterion [2]) diagram of the electric drive in dependence on the relative load current I_R . Three curves are presented: $Q-M$ curve is obtained using designed Mamdani-type FLD in the $FLVSC$, $Q-S$ curve is obtained using designed Sugeno-type FLD , and $Q-Inv$ curve is obtained from the investigations [2] and demonstrate the optimal dynamical quality of the electric drive. It is seen from the Fig. 6, that all curves coincide and

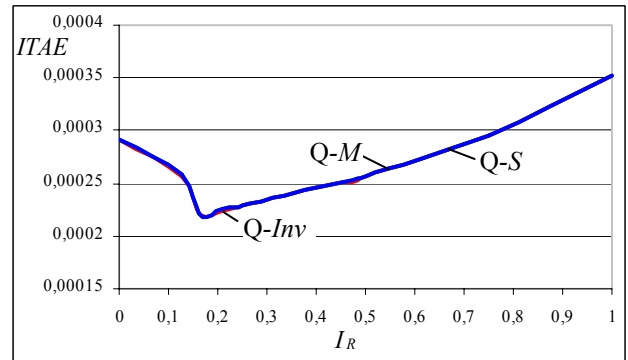

Fig. 6. Dynamical quality (defined by the $ITAE$ quality criterion) of the electric drive in dependence on the relative load current

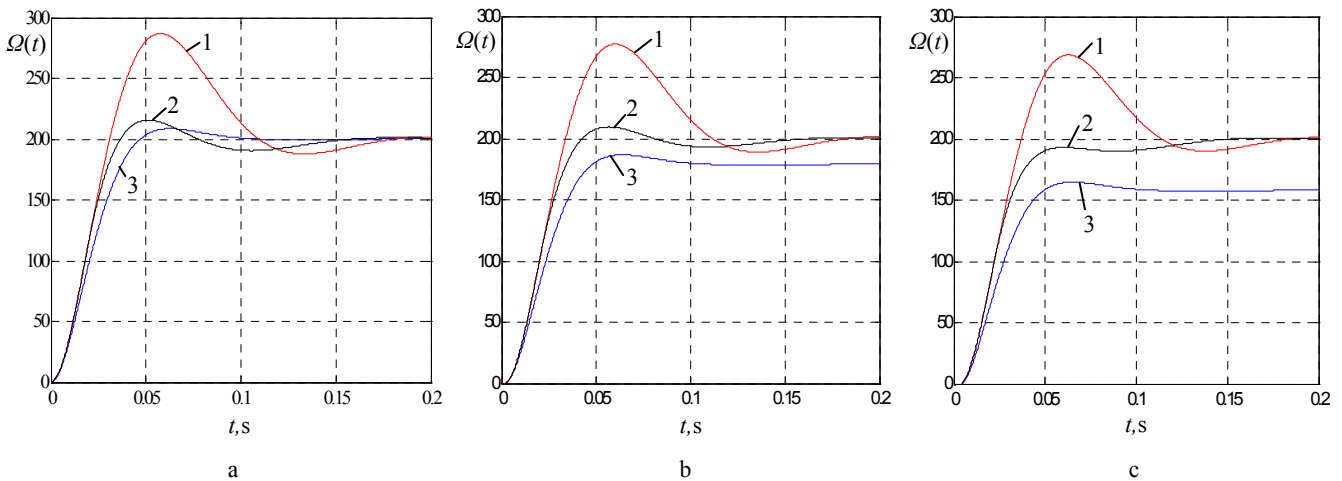

Fig. 7. Velocity curves of the transient regime: a - in the idle case, b - in the static load $I_L=0.5I_N$ case, c - in the static load $I_L=1I_N$ case

thus according to the *ITAE* quality criterion [2], the optimal dynamical quality is obtained using both Fuzzy logic devices (Mamdani-type and Sugeno-type).

The velocity transient regime curves obtained using variable and conventional structure velocity controllers are presented in Fig. 7. There the curves obtained using velocity controller adjusted under the symmetric optimum condition are denoted by number 1, in the case of using Fuzzy logic based variable structure velocity controller *FLVSC* (with Mamdani-type or Sugeno-type *FLD*) - by number 2, and in the case of using velocity controller adjusted under the quantitative optimum condition - by number 3. It is seen from the Fig. 7, that in all cases, the rapidity of the drive with *FLVSC* has been increased comparing to the drives with conventional structure velocity controllers. Hence the dynamical quality of the electric drive has been improved using Fuzzy logic based variable structure velocity controller.

Conclusions

1. The electromechanical servo drive with variable structure velocity controller commanded by Fuzzy logic based control law (*PI-P-PI*) switching device is developed and investigated. Fuzzy logic device is used for *P* control law interval time definition in dependence on the static load level of the drive.

2. The applied Fuzzy logic control method allows ensuring optimal dynamical quality (defined by *ITAE*

quality criterion) of the control process independently on the drive load conditions.

3. Two types (Mamdani-type and Sugeno-type) Fuzzy logic *P* control law interval time definition devices have been designed and investigated. Presented modeling results of the electromechanical servo drive confirm suitability of the proposed control method.

References

1. Šulčius N., Geleževičius V.A. Kintamos struktūros reguliatorių taikymas elektros pavarų greitaveikai didinti // Tarpt. konf. „Automatika ir valdymo technologijos 2004“ pranešimų medžiaga. – Kaunas: Technologija, 2004. – P. 114 – 118.
2. Šulčius N., Geleževičius V.A. Elektromechaninių vykdymo sistemų su kintamos struktūros reguliatoriais dinamikos kokybės tyrimas // Elektronika ir elektrotechnika. – Kaunas: Technologija, 2005. – Nr.7 (63). – P. 40 – 43.
3. Ross T. J. Fuzzy Logic with Engineering Applications. 2nd ed. – Hoboken: John Wiley & Sons, 2004. – 628 p.
4. Passino K. M., Yurkovich S. Fuzzy Control. – Menlo Park, California: Addison Wesley Longman, 1998. – 502 p.
5. Jang J.-S.R., Sun C.-T., Mizutani E. Neuro-Fuzzy and Soft Computing: A Computational Approach to Learning and Machine Intelligence. – Upper Saddle River: Prentice Hall, 1997. – 614 p.
6. Fuzzy Logic Toolbox User's Guide (For Use with MATLAB): <http://www.mathworks.com>, [2005 12 07].

Submitted for publication 2006 04 12

N. Šulčius, V. A. Geleževičius. Implementation of the Control Algorithm of the Variable Structure Controller in the Electromechanical Servo System // Electronics and Electrical Engineering. – Kaunas: Technologija, 2006. – No. 7(71). – P. 51–54.

The electromechanical servo drive with variable structure velocity controller commanded by Fuzzy logic based control law (*PI-P-PI*) switching device is developed and investigated. Fuzzy logic device is used for *P* control law duration time definition in dependence on the static load level of the drive. Applied Fuzzy logic control method allows ensuring optimal dynamical quality (defined by *ITAE* criterion) of the control process independently on the drive load conditions. Two types (Mamdani-type and Sugeno-type) Fuzzy logic devices for *P* control law duration time definition have been designed and investigated. Presented modeling results of the electromechanical servo drive confirm suitability of the proposed control method. Ill. 7, bibl. 6 (in English; summaries in English, Russian and Lithuanian).

Н. Шульчюс, В. А. Гяляжявичюс. Реализация алгоритма управления регулятора переменной структуры для электромеханической исполнительной системы // Электроника и электротехника. – Каunas: Технология, 2006. – № 7(71). – С. 51–54.

Рассмотрена электромеханическая исполнительная система с регулятором скорости переменной структуры, управляемым при помощи переключающего устройства, реализованного с применением метода *Fuzzy* логики, переключающего закон управления регулятора (*ПИ-П-ПИ*). Метод *Fuzzy* логики использован для определения длительности пропорционального (*И*) закона управления в зависимости от статической нагрузки электропривода. Примененный метод управления обеспечивает оптимальное качество динамики системы независимо от статической нагрузки. Исследованы два типа переключающих устройств *Fuzzy* логики: *Mamdani*-типа и *Sugeno*-типа. Результаты моделирования электромеханической исполнительной системы с регулятором переменной структуры подтверждают эффективность предложенного метода управления. Ил. 7, библи. 6 (на английском языке; резюме на английском, русском и литовском яз.).

N. Šulčius, V. A. Geleževičius. Elektromechaninės vykdymo sistemos kintamos struktūros reguliatoriaus valdymo algoritmo sudarymas // Elektronika ir elektrotechnika. – Kaunas: Technologija, 2006. – Nr. 7(71). – P. 51–54.

Nagrinėjama elektromechaninė vykdymo sistema su kintamos struktūros greičio reguliatoriumi, kuris valdomas *Fuzzy* logika pagrįstu valdymo dėsnio (*PI-P-PI*) perjungimo bloku. *Fuzzy* logikos įtaisas naudojamas proporcinio (*P*) valdymo dėsnio palaikymo trukmei nustatyti priklausomai nuo elektros pavaros statinės apkrovos dydžio. Taikomas *Fuzzy* logika pagrįstas valdymo metodas užtikrina optimalią sistemos dinamikos kokybę (remiantis *ITAE* kokybės kriterijumi) nepriklausomai nuo pavaros statinės apkrovos dydžio. Sukonstruoti bei ištirti dviejų tipų – Mamdani tipo ir Sugeno tipo *Fuzzy* logikos įtaisai. Pateikti elektromechaninės vykdymo sistemos modeliavimo rezultatai patvirtina pasiūlyto valdymo metodo tinkamumą. Il.7, bibl. 6 (anglų kalba; santraukos anglų, rusų ir lietuvių k.).