

Enhancement of Conducted Noise Suppression in EMI filters

V. Scavinskis, J. Jankovskis

Faculty of Electronics and Telecommunications, Riga Technical University

12 Azenes str., Riga LV-1048, Latvia, phone: +371-7089292; e-mail: vladimirs@one.lv; jankovsk@rsf.rtu.lv

Introduction

Most of the stationary IT devices take their energy from the a-c mains by means of the switch-mode power supply. Unfortunately switch-mode power energy conversion process produces powerful interferences in a broad radio frequency range. This issue is solved with introduction of electromagnetic interference (EMI) filters, which realize a very important task in modern power supplies – conducted high frequency noise suppression. According to the EMI standards the frequency range of interest covers frequencies from 150kHz up to 30MHz [1]. However, it doesn't mean that there is some inconsistency after 30MHz. This is actually a limit after which the signal may start to radiate into the ambient, creating negative influence on the nearby electronic facilities. Most of the filters can deal with the frequencies up to 30MHz, still leaving higher frequency range, with little worries about it. Therefore it is necessary to continue improvements of the EMI filter parameters, especially the higher frequency range noises attenuation. The most important parameter in determining the performance of the choke is the self-capacitance (parasitic capacitance). Actually most chokes used in this applications are beyond self-resonance. The presence of the parasitic capacitance severely limits the maximum suppression possible at high frequencies. It is difficult to obtain more than 6 to 12dB insertion loss at high frequencies above 30MHz [2].

During the last two years there were published several materials proposing different types of parasitic

coupling cancellation [1, 4, 6]. However they propose the technique which requires introduction of additional elements, and results in increased spacing requirements. Several publications has another way (traditional) of improving EMI filter parameters – optimization of the parameters of existing elements in order to gain necessary noise suppression [3, 7]. It is hard to decide what is better. We will follow the traditional way of improving filter frequency behavior.

This paper is aimed to make mains EMI filters with better parameters, all of the suggestions are given for the filter inductive components: there are made several attempts to expand filter active frequency range, by decreasing the influence of self-capacitance.

Aim and Object

To receive a real life results and to be able to compare proposed technique with the one currently used, we have used a regular EMI filter produced by Arcotronics Company Fig.1. Following the typical EMI filter topology Fig.2, filter has capacitive and inductive components. Capacitive component C_x serve to contend with differential mode noises, but C_{y1} and C_{y2} contend with common mode noises. Inductive components L_c are designed to contend with common mode noises. As the self-parasitics of components determine the performance of the CMC, we will focus on the detailed analysis of the common-mode choke (CMC). The analysis of the ferrite core is very well described in [3], therefore will concentrate on the analysis of the inductive components of the CMC.



Fig. 1. The basis of measurements - Arcotronics EMI filter

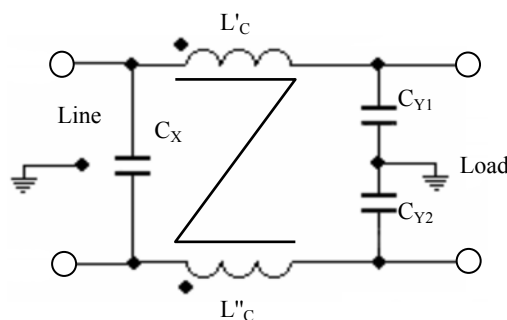

Fig. 2. Conducted EMI filter topology

CMC consists of two identical windings wound on a toroidal core in such a way that the magnetic fluxes caused by differential mode currents are canceled, i.e. magnetic fields due to the circulating differential current are canceled perfectly because of appropriate dot polarity [4]. In fact common-mode inductor is a neutralizing transformer, $L_c' = L_c''$, currents in which flow so that magnetic fields of both halves are compensated. The magnetic core in CMC is not air-gaped, thus offering high magnetic efficiency with the use of uniform cross sectional area so that influence on Q -factor is much more significant than in the case of differential mode inductance and CMC dimensions reduces dramatically. L_c works with the suppression fields, which strength is equal to the common mode noises. As it can be seen in [2], even the insignificant changes in self-capacitance lead to the obvious changes in filter frequency behavior. It is necessary to mention that any of the chokes will always have some certain parasitics. There is only a question of minimum achievable self-capacitance.

CMC parasitics decrease

The reasons which lead to the insufficient high frequency noise suppression are well described in [8]. We will mention just some of them. First of all in case of the solenoidal core it is not possible to gain the desired result in CMC applications, because the magnetic flux is closed in the immediate vicinity of the core instead of enclosing inside it, so it doesn't allow common flux routes realization. The appropriate choice for common mode attenuation is a closed ring (non air-gaped) core, which allows common flux routes realization. Nowadays E-cores are widely used as well, because of easier manufacturing method, but they also have certain disadvantages (parasitic effects in the end gap area). Some of the currently used CMCs have winding which lasts over the whole ferrite core surface, thus ending up with a significant self-capacitance C_0 , because both ends of the inductor are too close to each other. Increased self-capacitance in its turn has a negative influence on the system performance. Hence it is necessary to separate winding ends as far as possible in order to reduce the self-capacitance influence, similar to the solenoidal core case. As both ends are separated, C_0 will reach its lowest value which is proportional to the diameter D of coil. Improvement in relation to C_0 in this paper is related to the use of so called Smith-Wijn winding [5]. It is proposed to use the Smith-Wijn winding where we use the natural benefits of toroidal core (closed flux) and separated winding ends Fig.3.

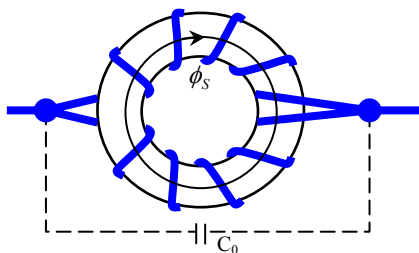

Fig. 3. Self-capacitance of the Smith-Wijn CMC

In the most popular type of CMC winding ends are separated enough to reduce C_0 to the very close level as in Smith-Wijn winding, however part of magnetic flux routes, the so called stray flux - ϕ_s , may enclose outside of the core. This problem in fact is solved in the proposed CMC configuration. There is additional benefit of this configuration: it is expected that interwinding capacitance C_w is higher than in the case of regular CMC, thus summing up with X-type capacitor C_x Fig.1., which improves filter differential mode characteristics.

There will also be performed an experiment with another idea of improving EMI filter parameters, which is based on the shielding of the CMC in order to reduce mutual and self parasitics between capacitors and inductors.

Experimental equipment

The measurements were performed with use of a Spectrum analyzer. We have used a Rhode & Schwarz Spectrum Analyzer FSP-30. The input of the filter was connected to the Spectrum analyzer sweep generator output, but filter output was connected to the spectrum generator input Fig.4. The physical model of device under test (DUT) is presented on Fig.5. All measurements results are presented on the logarithmic frequency scale starting from 1MHz and finishing with 1GHz.

There were two proposed CMC implementation measured during these experiments. First – similar to the original CMC: same winding number ($N = 45$) and similar wire diameter ($d = 0,2\text{mm}$). Second – CMC had $N = 5$, and $d = 0,45\text{mm}$. In all cases there was implemented the same ferrite core.

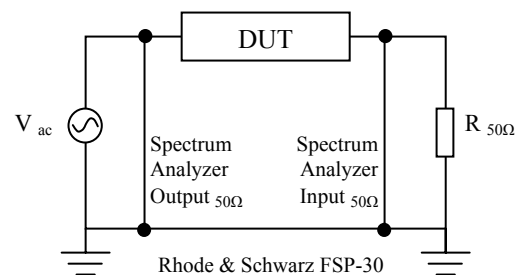

Fig. 4. Test circuit block scheme for EMI filter evaluation

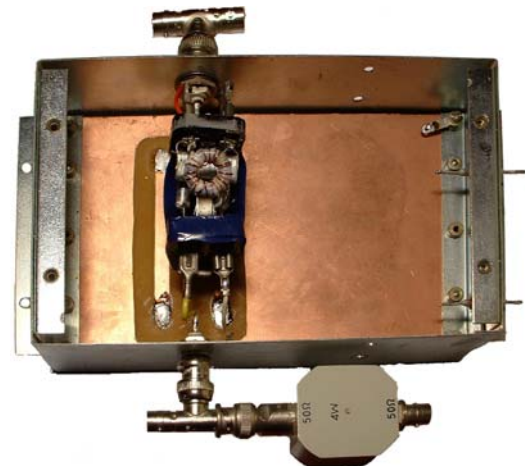

Fig. 5. Physical model of DUT (for EMI filter prototype measurements)

Experimental data

Several sets of measurements based on the previously mentioned requirements were performed. The analysis is based on the comparison of a standard EMI filter against same EMI filter where original CMC was substituted with the proposed one.

In this paper there are presented only 5 most interesting measurements. In the very beginning of the measurements it was found that the regular EMI filters are filled with some compound which preserves the parameters of the filter components, and doesn't allow components to move inside the filter. However the compound in the analyzed filter had permittivity which reduces the filter high frequency noise suppression, starting from the 30MHz and up to the 250MHz Fig.6. The worst case is at the 100MHz – difference is approximately 20dB. This is another task for the designers – to find a compound with lower permittivity value, in order to keep EMI filter parameters at the desired level.

The next step was to observe the difference in high frequency behavior between all three CMCs without remaining part of the EMI filter (all capacitors are disconnected). This is done to evaluate the plain CMC performance without capacitors. The results are shown on the Fig.7. Results received in this experiment are different from what we have expected – the plain Smith-Wijn winding seems to be less effective than the currently used one, but we still hope that further measurement will show better results.

To evaluate the insertion of Smith-Wijn CMC in the regular EMI filter there was performed another measurement Fig.8. This time we see that the proposed Smith-Wijn winding has some positive results at frequency range starting from 150MHz and up to the 450 MHz. The average suppression improvement is around 10 dB. But

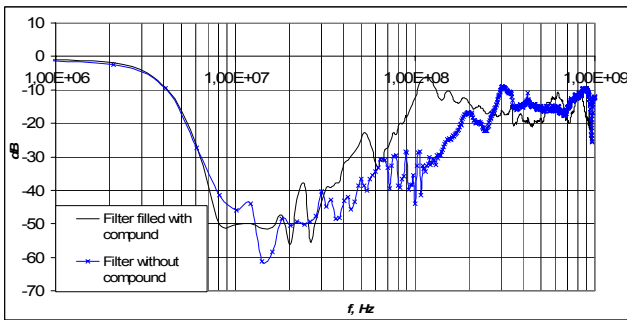

Fig. 6. Filter filled with compound and filter without compound

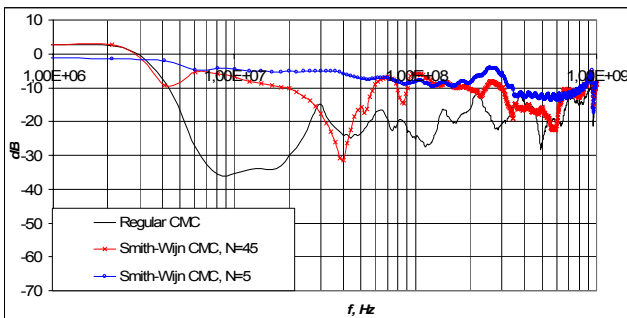

Fig. 7. Three different types of CMC with the same ferrite core

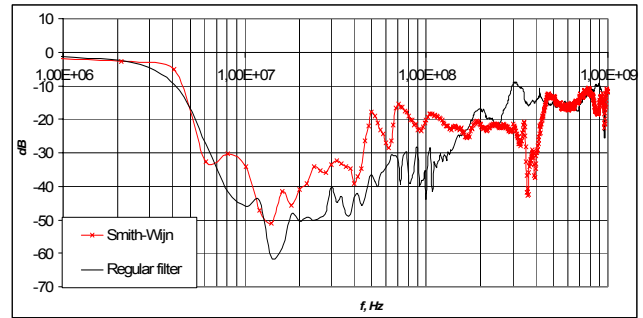

Fig. 8. Regular filter and filter with Smith-Wijn CMC

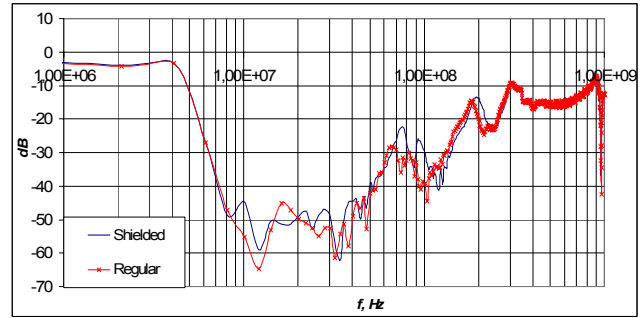

Fig. 9. Regular and copper shielded filters (regular CMC)

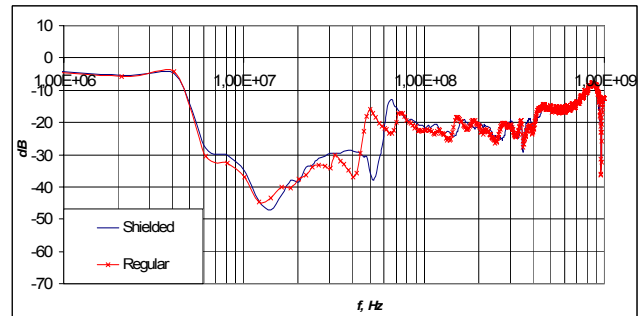

Fig. 10. Regular and copper shielded filters (Smith-Wijn CMC)

again in the frequencies up to the 150 MHz filter couldn't provide the desired noise suppression.

There is left the last idea of improving the EMI filter performance – copper shielding of the CMC in order to reduce mutual parasitics and self parasitics between EMI filter components. As it can be seen from Fig.9. and Fig.10 the result of introducing a copper shield is minimal at high frequencies and doesn't provide any additional benefit.

Conclusions

There were performed many experiments in order to evaluate the benefits of Smith-Wijn winding in comparison to the regular winding. Measurement results have shown that there are some certain advantages which allow performing better high frequency noise suppression. Average improvement of high frequency noise suppression is 10 dB in 150 MHz – 450 MHz frequency range. Additional research on the filter compound may improve filter efficiency in 30 MHz – 250 MHz frequency range. Smith-Wijn windings provide better high frequency noise suppression, but additional experiments are required, prior

to implementing it in some commercial applications. And last part of this research – CMC copper shielding, has not given any positive result, thus pointing out its vainness.

This work has been partly supported by the European Social Fund within the National Programme “Support for the carrying out doctoral study program’s and post-doctoral researches” project “Support for the development of doctoral studies at Riga Technical University”.

References

1. **Wang S., Chen R., Jacobus Daniel V. W.** Developing Parasitic Cancellation Technologies to Improve EMI Filter Performance for Switching Mode Power Supplies // IEEE Transactions on Electromagnetic Compatibility – 2005. – Vol. 47, No. 4. – P. 921 – 929.
2. **Ott H.W.** Noise reduction techniques in Electronic Systems. – J.Wiley & Sons, 1988.
3. **Waeckerlé T., Save T., Vachey B., Gautard B., Fraisse H.** Compared Nanocrystalline and Ferrite Optimized Common Mode Choke for RFI Filters Suitable as Compact Components // European Power Electronics Conference, Riga, September 2004.
4. **Mammano B., Carsten B.** Understanding and Optimizing Electromagnetic Compatibility in Switch-mode Power Supplies.
5. **Smith J., Wijn H. P. J.** Ferrites. – Eindhoven: Philips’ Technical Library, 1959.
6. **Wang S., Fred C. Lee, Willem G. O.** Improvement of EMI Filter Performance With Parasitic Coupling Cancellation // IEEE Transactions on Power Electronics – 2005, September. – Vol.20. – No.5. – P. 1221 – 1228.
7. **Sippola M., Siren H.** New winding method for common mode choke // Proceedings BEC’98. – Tallin, October 7-9, 1998.
8. **Scavinskis V.** Elements of Optimal Design of Inductive Components for EMI filters // Telecommunications and Electronics. – Riga, 2005, Series 7. – Vol. 5. – P. 36 – 39.

Submitted for publication 2006 03 01

V. Scavinskis, J. Jankovskis. Enhancement of Conducted Noise Suppression in EMI filters // Electronics and Electrical Engineering. – Kaunas: Technologija, 2006 – No. 7(71). – P. 39–42.

The introduction of modified Smith-Wijn winding into the Common Mode Choke has shown its advantages in comparison to the regular Common Mode Chokes only in the region of high frequencies. Unfortunately we haven’t received the expected results in the operational region of currently used EMI filters. Paper represents a new approach of enhancing EMI filter high frequency noise suppression, there are presented several experimental results of the proposed technique. Better results are achieved at frequencies from 150MHz up to the 450MHz with average improvement of noise suppression around 10dB. A new task has been assigned in order to improve the electromagnetic filter efficiency – optimizing the compound of EMI filters. Ill.10., bibl.8 (in English summaries in English, Russian and Lithuanian).

V. Щавинский, Я. Янковскис. Улучшение подавления кондуктивных помех в фильтрах ЭМС // Электроника и электротехника – Каунас: Технология, 2006 – № 7(71). – С. 39–42.

Замещение обычных обмоток синфазного фильтра на обмотку Смита-Вейна даёт некоторые улучшения в районе высоких частот. Мы рассчитывали получить несколько иные результаты чем ранее полученные в районе рабочих частот современных фильтров, но, к сожалению, это не удалось. Представлен новый способ, позволяющий улучшить подавление высокочастотных помех в фильтрах ЭМС. Также представлены некоторые экспериментальные результаты, полученные при применении данного способа. Улучшения удалось достичь на частотах от 150 МГц и до 450 МГц, со средним улучшением значения подавления помех около 10дБ. По ходу работы появилась очередная задача, позволяющая повысить эффективность фильтров ЭМС – оптимизация материала наполнителя фильтров ЭМС. Ил. 10, библи. 8 (на английском языке; рефераты на английском, русском и литовском яз.).

V. Scavinskis, J. Jankovskis. Laiduminio pobūdžio triukšmų slopinimo EMI filtruose gerinimas // Elektronika ir elektrotechnika. – Kaunas: Technologija, 2006 – Nr. 7(71). – P. 39–42.

Įprastų sinfazinio filtro apvijų pakeitimas *Smito ir Veino* tipo apvijomis teikia tam tikrų pranašumų tik aukštųjų dažnių srityje. Deja, mes negavome lauktų rezultatų atliekdami tyrimą šiuolaikinių EMI filtrų darbo dažnių diapazone. Pateikiamas naujas būdas, leidžiantis pagerinti aukštojo dažnio triukšmų slopinimą EMI filtruose. Pateikiami aprašyto metodo eksperimentinio tyrimo rezultatai. Geresni rezultatai buvo gauti dažnių diapazone nuo 150 MHz iki 450 MHz. Vidutinis triukšmo slopinimo padidėjimas sudarė apytiksliai 10 dB. Atliekant tyrimą buvo suformuota nauja užduotis, kurią reikėtų išspręsti norint padidinti elektromagnetinių filtrų efektyvumą, – optimizuoti EMI filtrus užpildančią medžiagą. Il.10, bibl.8 (anglų kalba; santraukos anglų, rusų ir lietuvių k.).

DOI: 10.5755/j02.eie.10768