

The Investigation of Thermodynamic Processes in Pulsed Magnets

S. Bartkevičius, J. Novickij

Department of Electrical Engineering, Vilnius Gediminas Technical University,

Naugarduko st. 41, LT-03227, Vilnius, Lithuania, tel.: +370 52 744762; e-mail: elektrotechnika@el.vtu.lt

Introduction

Recently pulsed magnets are used in many areas of applied sciences and engineering. Therefore the technique of non-destructive pulsed magnetic generation has become very important and is under continuous development [1].

One of most attractive and technological way to generate pulsed magnetic fields is the capacitor bank discharge with thyristor switches through reinforced wire wound coils. Such equipment is in common use [2].

However simple principle of operation requires great efforts to ensure long life of operation of applied pulsed coils. The design of non-destructive pulsed coils is a complex technical problem because they operate under very heavy conditions. Pulsed coil construction has to deal with mechanical, thermal and electrical overloads occurring due to Lorence force and Joule heating [3].

In recent years the great progress has been done in pulsed coil design. First, many new materials with unique technical parameters have been developed. Such micro-composite conductors like Cu-Nb, Cu-Ag combine good conductivity (65-75% of the International Annealed Copper Standard) and high mechanical strength (ultimate tensile strength in order of 1-1,5 GPa) and are applicable. Winding insulation using modern material like Kapton®, glass fibers and further reinforcement with Zylon®, carbon fiber composites allows to construct non-destructive pulsed coils (at least for 100 pulses) for magnetic field generation in the range of 50-70 T, where usual materials are out of the application due to destructive overloads [4]. Secondly, many efforts were done for the optimization of pulsed coil construction. The possibility to use powerful hardware and software for the analysis and data simulation of designed pulsed coils allow improving the construction, predicting available failures, increasing the efficiency of energy transformation. Electromagnetic, thermodynamic, mechanical processes take place during pulsed coil operation have been analyzed by different rules [5-8].

Rapid heating during pulsed coil operation leads to changes of electrical properties of applied materials. It can decrease the coil efficiency and reliability. In present article thermodynamic processes, their influence on value

of maximal generated magnetic field, thermal overloads and construction reliability are analyzed.

Model description

The model is accomplished using electrical circuit which consists of capacitor bank, thyristor switch, line cables and inductor (pulsed coil) itself connected in series. The diagram of such circuit is shown in Fig.1.

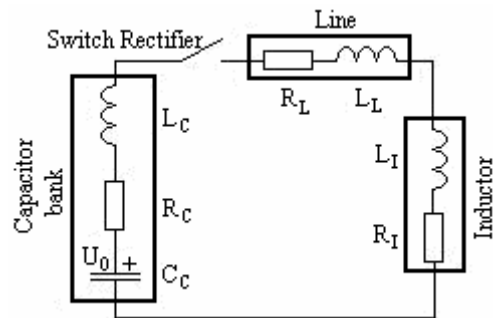

Fig. 1. Pulsed inductor control circuit

Parameters L_C, R_C were not taken into account, while line cables were considered to be very short (inductor is very close to capacitor bank's output leads), therefore parameters $L_L, R_L \rightarrow 0$. On the other hand pulsed coil parameters L_I, R_I are more significant than L_C, R_C and L_L, R_L for most real applications.

Capacitor bank's capacitance is C_C and it is charged to a voltage U_0 . The discharge of a capacitor bank through the inductor could be defined according to 2nd Kirchoff's law for the circuit when the SCR is on

$$U_0 = R_I i(t) + L_I \frac{di(t)}{dt} + \frac{1}{C_C} \int i(t) dt. \quad (1)$$

Laplace transformation for equation given above is

$$U_0(s) = R_I I(s) + L_I s I(s) + \frac{I(s)}{C_C s}. \quad (2)$$

Having $U_0(s)$ as an input and circuit current $I(s)$ as an output for magnetic field calculation we obtain a transfer function in a form:

$$W_{Circuit}(s) = \frac{I(s)}{U_0(s)} = \frac{1}{1 + \frac{L_I s + R_I}{(L_I s + R_I) C_C s}} \quad (3)$$

Obtained transfer function corresponds to the model created in *Matlab*® *Simulink*® and is shown in Fig. 2.

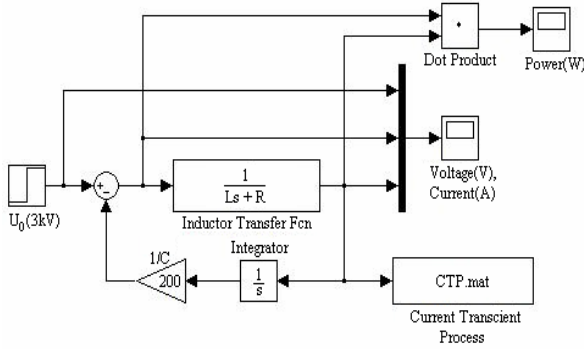

Fig. 2. Inductor control circuit *Matlab*® *Simulink*® model for capacitor bank charged to $U_0=3$ kV, $C=5$ mF

Presented model is controlled by author's written program. Having initial geometrical (size ratios, wire mass parameters, layers' parameters) and electrical (specific resistivity, resistance, inductivity, etc.) inductor parameters the maximal value of current pulse and magnetic field distribution can be given. The simulation for every time moment recalculating the Joule heating, heat dissipation, temperature and resistance (specific resistance) increase are performed. All the data is recorded and can be analyzed in many different ways. The approach is flexible and universal because it is fully programmable and is not limited for one specific operation.

Model control

To start simulation basic inductor parameters (inner radius a_1 , outer radius a_2 , inductor length $2b$, size ratios $\alpha = a_2/a_1$, $\beta = b/a_1$ filling factor λ , number of wounds per layer n_1 , number of layers n_2 , total number of wounds N , resistivity ρ as well as form factor $g(\alpha, \beta)$ and starting temperature T_0) must be given. Using these other essential parameters like inductor wire length l , inductance L and wire resistance R are calculated [9]:

$$L = a_1 \frac{\mu_0 \pi (\alpha + 1)^2}{8\beta} N^2 g(\alpha, \beta); \quad (4)$$

$$R = \frac{\pi \rho N^2 (\alpha + 1)}{2a_1 \lambda \beta (\alpha - 1)}. \quad (5)$$

Using the glass fiber wire isolation and one *Zylon*® layer for reinforcement technology for n_2 wiring layers

we obtain $4n_2$ layers for inductor's cross-section if the metal reinforcement container is not considered. The mass m (the density must be given for every material), surface area A , layer width w , specific heat c and thermal conductivity k are calculated for every layer in order to evaluate the heat dissipation to the surrounding layers and the environment during the pulse. The parameters c and k are unique for every material and they are as well dependent on temperature.

The program runs simulation, records the current transient and using the current value $i[N]$ at the time moment $t[N]$ calculates the Joule heating and temperature increment for every wire layer:

$$dQ_j = i^2[N]R_j dt; \quad c \cdot m = c_j(T); \quad dT_j = \frac{dQ_j}{m_j c_j}. \quad (6)$$

Heat dissipation for every layer n is recursively evaluated using the equation:

$$dQ_n = k_n(T) A_n \frac{dT_{-n,+n}}{w_n} dt. \quad (7)$$

Finally the specific resistance $\rho_j = \rho_j(T)$ and resistance $R_j \sim \rho_j$ for every wire layer are calculated and used for another simulation. The cycle is repeated until current impulse value diminishes to 1 % of its maximum.

The change of the resistance influences the current value for the time moment $N+1$ and the duration of the current impulse completely changing the current transient process and achieved magnetic field maximum.

Numerical simulation

For the numerical experiment two pulsed coils A and P were used. The essential parameters for A and P are given in Table 1.

Table 1. Pulsed coils parameters

Parameter	Value	
	Inductor A	Inductor P
a_1 , mm	6	6
a_2 , mm	16	24
$2b$, mm	30	48
λ	0.4755	0.6913
n_1	13	10
n_2	6	6
Material	Cu-Nb	Cu-Nb
Composition	82 % Cu	82 % Cu
σ , % IACS	65(293 K)	63(293 K)
T_0 , K	77	77

For the experimental verification of simulated results pulsed generator was used [10]. Capacitor bank of total capacity of 5000 μ F was charged up to $U_0 = 3$ kV. Both pulsed coils were cooled down to liquid nitrogen temperature (77 K). Real inductor identical to A was tested in above mentioned conditions in laboratory and it exploded giving maximal magnetic field of 48 T. Further behaviour of pulsed coil A was tested virtually by numerical simulation to identify the cause of coil

destruction. As to pulsed coil P, it serves here as a prototype inductor that has to be tested for future's fabrication. A non-destructive operation and long life application are forecasted.

The specific resistance for Cu-Nb_A (293 K – 65% IACS, 18% Cu + 82% Nb) and Cu-Nb_P (293 K – 63% IACS, 18% Cu + 82% Nb) wires were derived taking into account the fact that $\rho_A(293K)/\rho_A(77K) = 4.5$ and $\rho_P(293K)/\rho_P(77K) = 4.93$. The specific resistance for inductor A and P were approximated then respectively:

$$\begin{aligned} \rho_A(T) &= -3.41 \cdot 10^{-3} + 7.2 \cdot 10^{-5} T \cdot (1.80 - 0.0012T), \\ \rho_P(T) &= -3.41 \cdot 10^{-3} + 7.2 \cdot 10^{-5} T \cdot (1.70 - 0.0007T). \end{aligned} \quad (8)$$

The densities for glass fiber, Zylon®, Cu-Nb and liquid nitrogen are 2463, 1540, 8896 and 808 kg/m³ respectively. Density's changes during the pulse heating process are not estimated.

The Cu-Nb specific heat is recalculated multiplying basic value by the coefficient 0.9435 that was calculated according to given Cu-Nb composition. The specific heat for liquid nitrogen doesn't change with the temperature and has a value of 1042 J/(kg·K).

Thermal conductivities for glass fiber and Zylon® were also derived while thermal conductivity for Cu-Nb is recalculated multiplying the well known dependence on temperature for Cu by the factor 0.8449 that was also calculated according to known Cu-Nb composition.

Electrical parameters were measured in the laboratory for pulsed coil A and were $R_A(293K) = 0.115 \Omega$, $L_A = 44.2 \mu H$ (calculated $R_A(293K) = 0.1144 \Omega$, and $L_A = 40.0 \mu H$). The numerical experiment for pulsed coil A was carried out using measured quantities. The calculated electrical parameters for pulsed coil P were $R_P(293K) = 0.0169 \Omega$, $R_P(77K) = 0.0034 \Omega$, $L_P = 31.5 \mu H$. Results of numerical simulation of temperature transient processes in Cu-Nb windings for pulsed coils A and P are shown in Fig. 3.

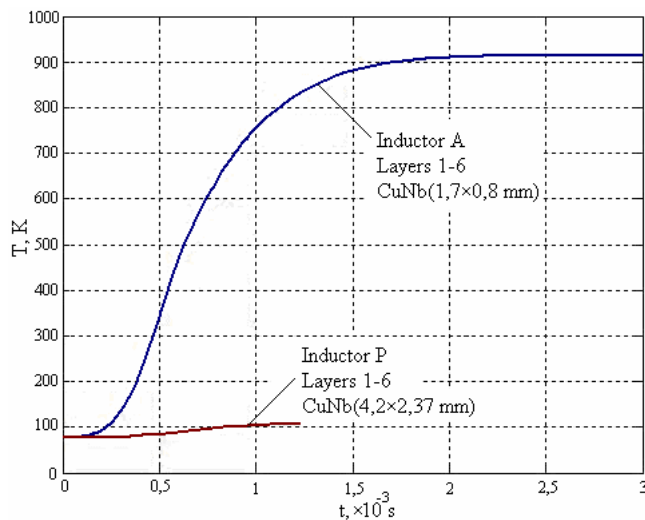

Fig. 3. Temperature transient process in pulsed coil A and P

Magnetic flux density's B_0 (magnetic flux density's value in the centre of pulsed coil bore) transient process for inductors A and P is shown in Fig. 4 when the heating is evaluated ($T=Var$) and neglected ($T=77K$).

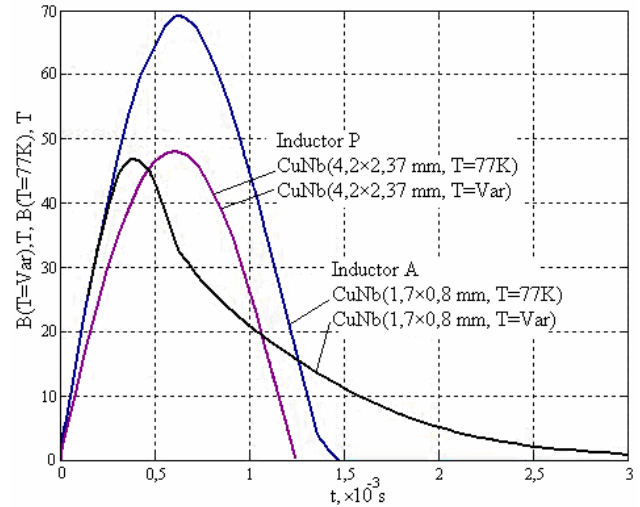

Fig. 4. Magnetic field transient process for pulsed coils A and P

The temperature after the pulse inside the coil A is many times higher comparing with the coil P and it strongly influences electrical properties of applied materials. Due to the increase of specific resistance of micro-composite Cu-Nb wire the total resistance of the winding increases a lot and the maximal value of generated magnetic field is around 40 % lower than expected (when heating is neglected), the pulse shape is distorted, the pulse maximum is shifted to the left. Contrary to A, pulsed coil P operated in the same conditions using the same equipment and was able to generate equivalent magnetic field of 48 T without significant overheating. The observed pulse shape is close to sinusoidal one, there is almost no shift of maximum of the pulse observed.

Conclusions

The analysis of thermodynamic processes taking place in pulsed coils has been carried out. It was proved that coil heating is close to adiabatic process and dissipation of heat is insignificant. Therefore great overheating due to Joule heating should be taken into consideration in pulsed coil design to ensure their longer life operation. Coil heating strongly influences the maximum value of generated magnetic field and the overheating can damage interlayer insulation. This fact was confirmed experimentally when manufactured pulsed coil identical to numerically simulated coil A were disintegrated. Observed character of defects looked like the damage due to overheating of winding insulation. Thermal capacity of windings can be increased constructively using a wire with greater cross-section to avoid the overheating. The prototype of pulsed coil P is expected to generate equivalent pulse of magnetic field of 48 T without significant overheating. Thus the correct choice of cross-section of wire can increase the reliability of designed pulsed coils. Further optimization of coil geometry should be done to ensure effective energy transformation.

References

1. **Herlach F.** Laboratory electromagnets-from Oersted to megagauss // *Phys.B.* – Elsevier, North-Holland, 2002.– Vol.39. – P. 321–329.
2. **Lagutin A., Rosseel K., Herlach F., Vanacken J., Bruynseraede Y.** Development of reliable 70 T pulsed magnets // *Measurement Science and Technology.* – IoP, 2003. – Volume 14. – P. 2144–2150.
3. **Novickij J., Kačianauskas R., Filipavičius V., Tolutis R., Balevičius S., Žurauskienė N.** Inductors for High Magnetic Field Generation // *Electronics and Electrical Engineering.* – Kaunas: Technologija. – 2004. – No. 7 (56). – P. 19–24.
4. **Schneider-Muntau H. J., Han K., Bednar N. A., Swenson C. A., Walsh R.** Materials for 100 T Monocoil Magnet // *IEEE Transactions on Applied Superconductivity.* – 2004. – Vol. 14(2). – P. 11531–156.
5. **Peng T., Gu C. L., Rosseel K., Vanacken J., Herlach F.** Advanced numerical simulation of pulsed magnets with a finite element method // *Measurement Science and Technology.* – IoP, 2005. – Vol.16. – P. 5625–68.
6. **Balevičius S., Žurauskienė N., Novickij J., Kačianauskas A., Kačianauskas R., Stupak E.** Decoupled Algorithm for coupled magneto-mechanical analysis of coils by the FEM software // *Information Technology and Control.* – Kaunas, Technologija, 2003. – Vol. 3(28). – P. 54–61.
7. **Vanaken J., Liang L., Rosseel K., Boon W., Herlach F.** Pulsed magnet design software // *Phys.B.–Elsevier, North-Holland, 2001.* – Vol. 295. – P. 674–678.
8. **Višniakov N., Novickij J., Bartkevičius S.** Simplified numerical simulation of pulsed magnets with a finite element method // *Electronics and Electrical Engineering.* – Kaunas: Technologija, 2006. – No. 3 (67). P. 47–50.
9. **Herlach F., Miura N.** High Magnetic fields. Magnet Technology and Experimental Techniques // *Science and Technology.* 2003. – Vol. 1. – P. 336.
10. **Novickij J.** Measurements in Pulsed Magnetic Fields // *Proc. of 5–th International Conference on Measurement.– Smolenice, Slovakia.* – 2005. – P. 514–517.

Submitted for publication 2007 02 05

S. Bartkevičius, J. Novickij. The Investigation of Thermodynamic Processes in Pulsed Magnets // Electronics and Electrical Engineering. – Kaunas: Technologija, 2007. – No. 5(77). – P. 19–22.

The analysis of thermodynamic processes in pulsed coils applicable for pulsed magnetic field generation has been done. Process modelling was carried out using *Matlab® Simulink®* software. Heating influence on maximal value of generated magnetic field and available coil failure are evaluated. The model was applied for numerical simulation of transient processes took place in pulsed coils generating magnetic fields in order of 50-70 T. It was found that overheating of wire wound coil can damage interlayer insulation led to further coil failure. The numerical simulation of pulsed currents, magnetic field and temperature rise were done for different pulsed coil constructions generated equivalent magnetic field using the same experimental equipment. Recommendations to protect pulsed coils against overheating by the increase of thermal capacity were offered. Applied model was verified experimentally and acceptable compliance of experimental and numerically simulated results was achieved. Ill. 4, bibl. 10 (in English; summaries in English, Russian and Lithuanian).

С. Барткевичюс, Ю. Новицкий. Исследование термодинамических процессов в импульсных магнитах // Электроника и электротехника. – Каунас: Технология, 2006. – № 5(77). – С. 19–22.

Рассматриваются термодинамические процессы, происходящие в импульсных электромагнитах во время генерации магнитных полей порядка 50–70 Т. Моделирование термодинамических процессов проведено, используя программный пакет *Matlab® Simulink®*. Представлена структурная схема моделируемого объекта. Модель электромагнита позволяет имитировать реальные процессы нагрева обмотки электромагнита при протекании импульсного тока. Оценивается влияние нагрева обмотки электромагнита на максимальное значение импульсного магнитного поля. Установлено, что нагрев проводника, близкий по характеру адиабатическому процессу, приводит к значительному изменению активного сопротивления обмотки электромагнита, что значительно снижает максимальное значение генерируемого магнитного поля и эффективность электромагнита. Приводится сравнительный анализ двух импульсных электромагнитов, обмотки которых намотаны проводом из микрокомпозиционного Cu-Nb сплава. Результаты численного эксперимента сравниваются с результатами реального физического эксперимента и достигнуто приемлемое соответствие результатов. Предложены рекомендации по уменьшению термических перегрузок путем увеличения теплоемкости конструкции импульсного электромагнита. Анализ термодинамических процессов в усовершенствованной обмотке, намотанной проводом большего поперечного сечения при прочих идентичных условиях эксперимента подтверждает правильность такого технического решения, так как значительно снижается перегрев обмотки, что в конечном итоге приводит к увеличению надежности и эффективности импульсного электромагнита. Ил. 4, библи. 10 (на английском языке; рефераты на английском, русском и литовском яз.).

S. Bartkevičius, J. Novickij. Impulsinių magnetų termodinaminių procesų tyrimas // Elektronika ir elektrotechnika. – Kaunas: Technologija, 2007. – Nr. 5(77). – P. 19–22.

Pateikta termodinaminių procesų, vykstančių impulsiniams magnetiniam laukui generuoti naudojamuose induktoriuose, analizė, kuri buvo atlikta tiek laboratorijoje, tiek imituojant kompiuteriu. Imitacijai pritaikytas programų paketas *Matlab® Simulink®*, įgalinantis sudaryti lankstų ir universalų, lengvai tobulinamą bei keičiamą sistemos elektromagnetinį ir termodinaminį modelį. Imitavimo tikslas buvo nustatyti induktorių išilimo įtaką generuojamai maksimaliai magnetinio lauko vertei bei induktoriaus naudojimo ilgaamžiškumui, taip pat patikrinti ir pagrįsti anksčiau eksperimentiškai gautus rezultatus bei įvertinti modelio tikslumą ir jo taikymo minėtiesiems procesams imituoti galimybes. Sudarytas modelis pritaikytas eksperimentiškai patikrintiems ir dar projektuojamiems induktoriams. Remiantis gautaisiais apvijų srovių, magnetinio lauko impulsų bei apvijų išilimo pereinamaisiais procesais nustatyta, kad išilimas impulso metu gali turėti didelę įtaką magnetinio lauko impulso formai ir amplitudei bei pažeisti tarpvijinę ir tarpsluoksninę izoliaciją ir tapti visiško induktoriaus sugadinimo priežastimi. Remiantis šiais rezultatais pateiktos rekomendacijos impulsinio induktoriaus naudojimo trukmei ilginti didinant jo šiluminę talpą, kai generuojamas 50–70T amplitudės magnetinis laukas. Taip pat pasiektas pakankamas skaitmeninių eksperimentų, atliekamų imituojant, tikslumas ir galimybė modelį bei gautus rezultatus taikyti termodinaminiam ir elektromagnetiniam procesams impulsiniuose induktoriuose prognozuoti, induktoriams tobulinti ir jų geometriniam bei elektriniams parametrų parinkti. Il. 4, bibl. 10 (anglų kalba; santraukos anglų, rusų ir lietuvių k.).

DOI: 10.5755/j02.eie.10731