

Research of Electrodynamical Processes in Vacuum Evaporation System

V. Sinkevičius, D. Viržonis, L. Šumskienė, T. Jukna

Department of Electrical Engineering, KTU Panevezys Institute,

S.Daukanto str. 12, 35212 Panevezys, Lithuania; tel.+370 45 434247, e-mail: vytenis@elekta.lt, darius.virzonis@ktu.lt

Introduction

The flow of the thermionic emission always creates evaporating the material on high temperature in vacuum. This flow deposits onto the plane of the condensed material and can be used for the non-invasive research of the condensate electrical properties. Also this flow can give information about the temperature and the state of the evaporator [1]. However, in the camera of the evaporating system the flow of the thermionic emission charges is under the influence of the electromagnetic field, created by the alternating current of the evaporator, and the electrostatic field, created by the supply voltage of the evaporator. These fields are also natural and it is not impossible to decrease their influence. Under the influence of these fields the direction of the charges flow and the current density become alternate and they are alternating periodically together with the alternation of the supply voltage. It was beholden, that the reaction of the charges flow to the influence of the fields was with delay during the experiment. The flows became steady only after few milliseconds, when the voltage supply was turned out.

The theoretical research modelling the all vacuum system is complicated enough. There are many metalical constructions of the different configurations in it, also the construction of the evaporator is complicated having curvilinear planes [2,3] and the alternating electromagnetic and electrostatic fields are acting in it. Also it is complicated to estimate the influence of the space charge. Therefore the experimental way [4] was chosen to investigate how we can to use the flows of the nature emission for the information about the evaporation and condensation processes.

The experimental research

The experiments in the chamber of the vacuum evaporation system were performed (1 Fig.). All the measuring probes and the substrate, on which the vapour is condensing, are in it. The evaporator *I* is heated by the

alternating current, which is regulated by thyristor controller 2. The voltage of the evaporator U_g is measured on the clamps of the evaporator and the current i_g of it is measured by the current transformer 3. Two round metalical probes 4, 5 for the measuring of the temperature are over the evaporator. They are laid out not obstructing the probes 7, 8 and the substrate 6 situated above and their planes are vertical to the line connecting centres of their areas and the centre of the evaporator plane.

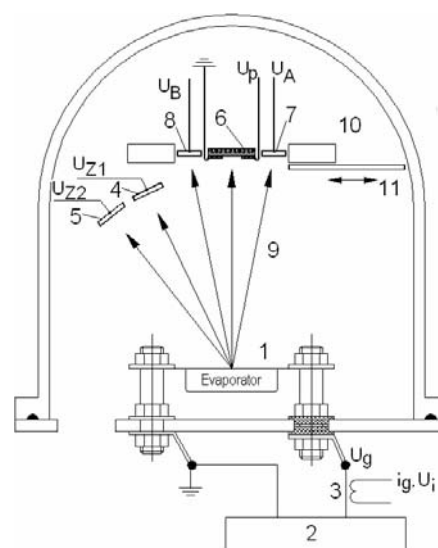

Fig. 1. The device of the experimental research: 1 – evaporator, 2 – thyristor controller, 3 – current transformer, 4, 5 – evaporator probes for the temperature measurement, 6 – the substrate for the research of the condensation process, 7, 8 – the probes for the identification of the thermionic emission parameters, 9 – the flow of the thermionic emission, 10 – the holder of the substrate's probes, 11 – shutter

The voltages of the probes U_{z1} and U_{z2} are used to find the temperature of the evaporator, measuring the current of the thermionic emission. Heated evaporator plane *I* creates the flow of thermionic emission charges 9, which is deflected by alternating magnetic field created by the current

flowing through the evaporator. Geometrically shifted probes 4, 5 allow us to research the influence of this magnetic field to the flow of the thermionic emission, which deposits onto the substrate 6 and the probes 7 and 8.

The substrate 6 and the probes 7, 8 are fixed in a holder 10 over the evaporator. Their measured voltages U_A and U_B are used for the identification of the charges flow 9.

At the start of the experiment the substrate 6 and the probes 7, 8 are covered by the shutter 11. Actuating the thyristor controller 2, the current flowing through the evaporator heats it and the evaporating material in it. When the due voltage generated by the thermionic emission current is obtained on the probe 4, the shutter 11 is opening. The flow of the material vapour and charges reaches the substrate 6 and the probes 7, 8 unimpeded. The result of typical experiment evaporating the chromium is shown on Figure 2. The experiment is finished, when the voltage of the substrate reaches minimum. Then the voltage supply is turning out or the shutter is closing.

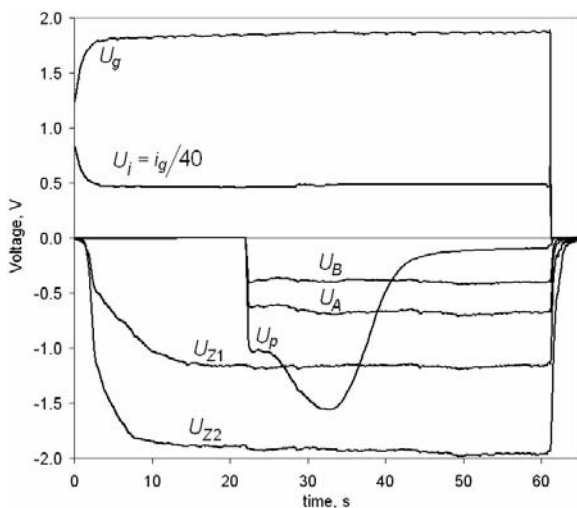

Fig. 2. The evaporator voltage U_g , current i_g , the voltages of probes U_A , U_B , U_{Z1} , U_{Z2} and the voltage of substrate's contact site U_p as the functions of time during the experiment

The module with eight channels NI 6036 was used for the measuring of the voltages. All the voltages were measured 80 times in every 20 ms period of the supplied voltage, because its frequency was 50Hz. Therefore all the results of the experiment were gained in time step 0,25 ms.

The curves of the values, derived from every period, are shown on Figure 2. However, at the moment of one period the electro dynamical processes are getting place in the vacuum system and the electromagnetic field created by the current flowing through the evaporator is dominating in these processes. The alternation of the current flowing through the evaporator i_g and the measured voltages of the probes U_{Z1} and U_{Z2} during the one period of the supplied voltage are shown on Figure 3. At the beginning of the period the magnetic field created by the positive current i_g deflects the flow of the electrons from the probes and the voltage of the probes drops. When the current decreases to zero, the flow of the electrons becomes steady after 3 ms and during the time of 2 ms the voltages of the probes are directly related only with thermionic emission. Exactly this moment is chosen for the indirect measuring of the plane

temperature. The negative current flowing through the evaporator deflects the flow of the electrons to the probes and then the voltage of probes increases. In the next interval, when the current of the evaporator is zero, the flow of the electrons doesn't become steady until the moment the current of the evaporator comes positive.

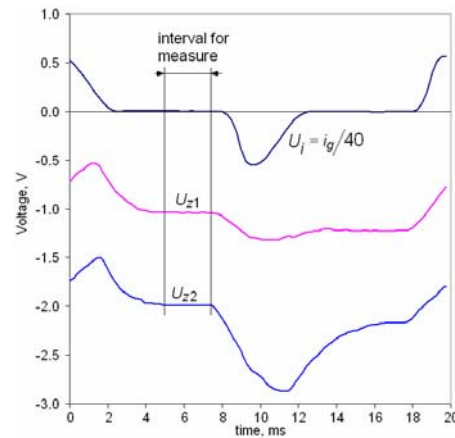

Fig. 3. The current of the evaporator i_g and the voltages of the probes U_{Z1} and U_{Z2} as the functions of time during one period

The measured voltages of probes U_A and U_B are alternating slightly in another way during one period (Fig. 4). These probes are rather away from the plane of the evaporator and near the vertical axis traced from the centre of the evaporator. Their destination is to identify the thermo electro moving force E and the resistance of the electrons flow r_E , therefore they are near the substrate. During the period the voltages U_A and U_B also change under the sway of the magnetic field created by the current of the evaporator. However, the electrons flow, reaching these probes, is steady and is not under the sway of the magnetic field only in a short interval. Exactly from this interval the meanings of the voltages U_A and U_B are used for the solving of the thermionic emission parameters identification problem.

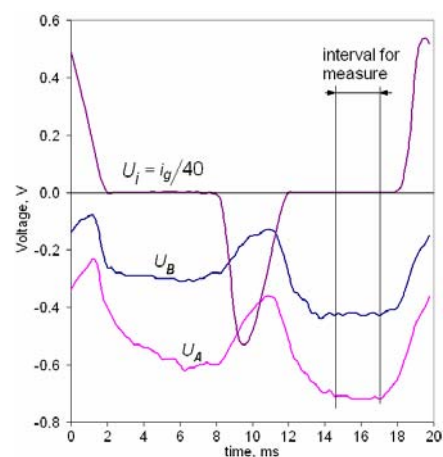

Fig. 4. The current of the evaporator i_g and the voltages of the probes U_A and U_B as the functions of time during one period

The equivalent measurement scheme

The equivalent measurement scheme for the identification of the thermionic emission parameters is

shown on Figure 5. The substrate for the condensate is shown here too. At the moment the shutter is opening, one contact site of the substrate also can be used like the probe. Later the atoms of the metal condense on the substrate and the part of the current flows to the earth through the condensate. The plane of the heated evaporator (the supply of the thermionic emission) is replaced by supply E and the influence of the work of electrons leaving and the space charge is changed by the equivalent inner resistance of the supply r_E . These E and r_E values will be used for the identification of the condensate resistance growing on the plane of the substrate. The inputs of the modules measuring the voltages of the probes U_A and U_B are shunted by the resistances r_A and r_B . The inner resistance of the modules input is r_M and the equivalent resistances of these parallel connected resistances respectively are r_{MA} and r_{MB} .

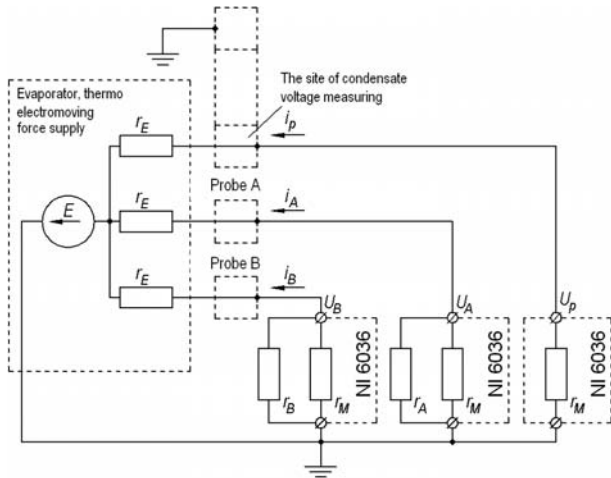

Fig. 5. The equivalent electrical scheme for the measurement of the thermionic emission parameters

The equations system describing the equivalent electrical links of the probes A and B is as follows:

$$\begin{cases} U_A = E \cdot \frac{r_{MA}}{r_E + r_{MA}}, \\ U_B = E \cdot \frac{r_{MB}}{k_s \cdot r_E + r_{MB}}. \end{cases} \quad (1)$$

The coefficient k_s estimate the difference of the evaporator in point of the geometrical location of probes. From the equation (1) the relation of the voltages U_A and U_B can be expressed as follows:

$$\frac{U_A}{U_B} = \frac{r_{MA} \cdot (k_s \cdot r_E + r_{MB})}{r_{MB} \cdot (r_E + r_{MA})}. \quad (2)$$

The relation of voltages U_A/U_B and the deviation of this relation from the average value as the functions of time are shown on Figure 6. The maximum deviation from the average reaches 6 %. The method of the identification is based on the same factors acting the flows of the electrons flowing to the either probes. However geometrically one of the probes is closer to the substrate and the potential of this probe begins to have the influence to the flow of the electrons.

The maximum time of the influence coincides with the maximum of the voltage U_p . From the equation (2) we expressed the equivalent inner resistance of the supply r_E as the function of the measured voltages U_A and U_B as follows:

$$r_E = \frac{U_B - U_A}{\frac{U_A}{r_{MA}} - \frac{U_B}{r_{MB}}} \cdot k_s. \quad (3)$$

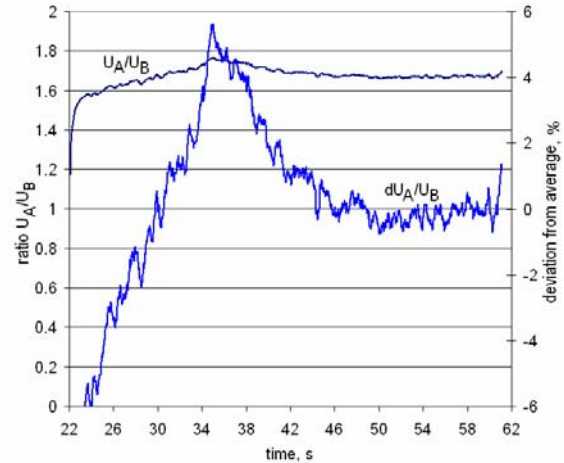

Fig. 6. The ratio between probes voltages during the process

In equation (3) the ratios of the voltage and resistance are the currents i_A and i_B flowing to the probes A and B (Fig. 7). The difference of these two currents is very small; therefore we used the method of the moving average filtration for the attenuation of the influence of noises to the results of calculation.

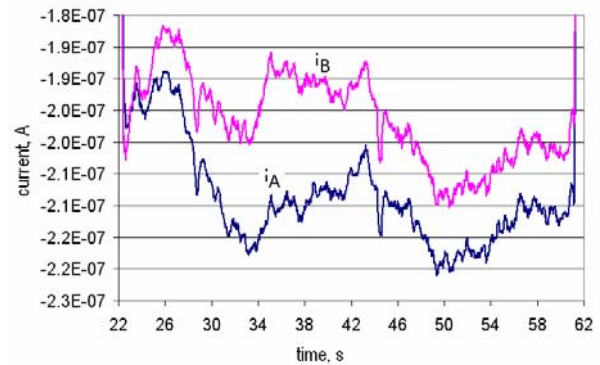

Fig. 7. The currents flowing to the probes A and B during the process

The calculation results, using the experimental data in the equation (3), are shown on Figure 8. At the start of the experiment, when the shutter is opening, the results of equation (3) can't be used for the identification of r_E , because the flows of electrons are not steady yet. The character of the identified r_E alternation repeats the character of the alternation of the ratio deviation (Fig. 6).

From the equation (1), having the identified r_E , we got the expression of thermo electro moving force E :

$$E = U_A \cdot \frac{r_E + r_{MA}}{r_{MA}}. \quad (4)$$

During the all process the alternation of the value E (equation (4)) was calculated using the values of r_E calculated by the equation (3) and the measured voltages of the probes U_A and U_B (Fig. 9).



Fig. 8. The alternation of the identified inner resistance of the supply during the process

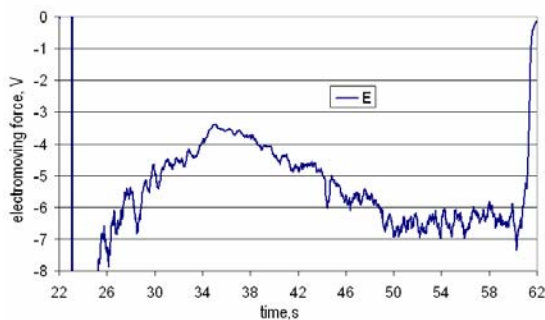

Fig. 9. The alternation of the identified thermo electro moving force during the process

It can be noticed (Fig. 9), that the value of the thermo electro moving force becomes steady above the value 6.5

V. And it is enough of two these identified values r_E and E for the calculation of the condensate resistance.

Conclusions

1. In the vacuum evaporating system the thermionic emission current, identifying the inner resistance and electro moving force of its supply, can be used as the natural supply of the electrons for the identification of condensate resistance.

2. The equivalent measurement scheme of the thermionic emission supply parameters and the calculation method, using two separated probes, allow us to identify the inner resistance and the electro moving force of the supply. However, it is necessary to obtain, that the influence of the outer factors would be very small to the electrons flowing to the probes in realization of this method.

References

1. **Virzonis D., Sinkevicius V.** Increasing the observability of the thin films manufacturing process // *Electronics and Electrical Engineering*. – 2004, – No. 4(53). – P. 42–45.
2. **Tarvydas P., Pacesaite E., Noreika A.** Modeling of Magnetic Field created by Coil in 3-D space // *Electronics and Electrical Engineering*. – 2004. – No. 7(56). – P. 29–32.
3. **Tarvydas P., Markevičius V., Noreika A., Pacesaite E.** Modeling of Electric Field created by Electronic Optical System // *Electronics and Electrical Engineering*. – 2005. – No. 1(57). – P. 20–23.
4. **Togawa K., Tanaka T., Onoe K., Inagaki T., Baba H., Shintake T.** Emittance Measurement On The Ceb6 Electron Gun For The Spring-8 Compact Sase Source Fel Project // *Proceedings of APAC 2004*. – Gyeongju, Korea. – 2004. – P. 158–160.

Submitted for publication 2007 03 01

V. Sinkevicius, D. Virzonis, L. Sumskiene, T. Jukna. Research of Electrodynamical Processes in Vacuum Evaporation System // *Electronics and Electrical Engineering*. – Kaunas: Technologija, 2007. – No. 4(76). – P. 75–78.

It was explored, that it was possible to get the information about the condensation processes evaporating the materials in the vacuum evaporating system. The method of the thermo electro moving force supply and its inner resistance calculation was created for that. Two extra probes for the temperature analysis and two another extra probes for the research of the thermionic emission supply were placed in vacuum camera for the experiments. It was estimated, that it was necessary to choose the place of the probes without the influence to each other. It was explored, that the density of the thermionic emission current could be measured only at the moments, when the current didn't flow through the evaporator. Ill. 9, bibl. 4 (in English; summaries in English, Russian and Lithuanian).

V. Синкявичюс, Д. Виржонис, Л. Шумскене, Т. Юкна. Анализ влияния температуры электродов на параметры ЭОС // *Электроника и электротехника*. – Каунас: Технология, 2007. – № 4(76). – С. 75–78.

Исследовано, что при термическом испарении в вакуумном устройстве можно получить дополнительную информацию о процессах конденсации. С этой целью создана методика расчёта эквивалентного источника термо эдс и его внутреннего сопротивления. Для экспериментального исследования в вакуумной камере установлены два дополнительных зонда для анализа температуры испарителя и зонда для исследования термоэлектронной эмиссии. Установлено, что требуется подобрать место зондов таким образом, чтобы исключить взаимное влияние. Экспериментально исследовано, что плотность тока термоэлектронной эмиссии можно измерять только при отсутствии тока, питающего испаритель. Ил. 9, библи. 4 (на английском языке; рефераты на английском, русском и литовском яз.).

V. Sinkevicius, D. Virzonis, L. Šumskienė, T. Jukna. Vakuuminės garinimo sistemos elektrodinamių procesų tyrimas // *Elektronika ir elektrotechnika*. – Kaunas: Technologija, 2007. – Nr. 4(76). – P. 75–78.

Ištirta, kad vakuuminio garinimo įrenginyje termiškai garinant medžiagas galima gauti papildomos informacijos apie procesus, vykstančius kondensacijos metu. Tam buvo sudaryta garintuvo termoelektrovaros ekvivalentinio šaltinio ir jo vidaus varžos apskaičiavimo metodika. Eksperimentiniams tyrimams vakuuminėje kameroje buvo įtaisyti du papildomi zondai garintuvo temperatūrai analizuoti ir du papildomi zondai termoelektroninės emisijos šaltiniui tirti. Nustatyta, kad zondu vietą reikia parinkti taip, kad jie nedarytų vienas kitam įtakos. Eksperimentiniu būdu ištirta, kad termoelektroninės emisijos srovės tankį galima matuoti tik tais laiko momentais, kai garintuvo srovė neteka. Il. 9, bibl. 4 (anglų kalba; santraukos anglų, rusų ir lietuvių k.).

DOI: 10.5755/j02.eie.10724