

Development for Automatic Welding System with Reduction of Residual Stress. - Effect of Vibrations with Different Frequencies

S. Aoki

*Monozukuri Department, Tokyo Metropolitan College of Technology,
1-10-40 Higashi-Ohi, Shinagawa-ku, Tokyo 140-0011, Japan, phone: +81 3 3471 6332; e-mail: aoki@tokyo-tmct.ac.jp*

S. Hirai, V. Saechout, M. Kohmura

Department of Manufacturing Technologist, Institute of Technologist, phone:+8148 564 3848; e-mail: hirai@iot.ac.jp

T. Nishimura, T. Hiroi

*Monozukuri Department, Tokyo Metropolitan College of Technology,
1-10-40 Higashi-Ohi, Shinagawa-ku, Tokyo 140-0011, Japan, phone: +81 3 3471-6331*

Introduction

Development of automatic welding system is an important problem for automatic manufacturing system. It is well known that residual stress is measured near the bead because base metal is heated near the bead [1]. Tensile residual stress on the surface degrades fatigue strength [2].

In this paper, the effect of vibrations with different frequencies on reduction of residual stress is examined. Firstly, two thin plates are butt-welded using ultrasonic vibrations with different frequencies on each plate. When thin plates are welded using ultrasonic vibrations with different frequencies, tensile residual stresses are reduced and reduction rate is largest compared with other conditions. Secondly, two thin plates are butt-welded using ultrasonic vibration and vibration with low frequency. In this case, tensile residual stresses are reduced and reduction rate is largest compared with other conditions. Thirdly, a welding of automobile wheel for automatic welding system is performed using ultrasonic vibration. As a result, it is confirmed that the reduction of residual stress is reduced. Finally, experimental results are examined by analytical method.

Welding with ultrasonic vibrations with different frequencies

When two thin plates are butt-welded, an ultrasonic vibration is applied on one plate and the other ultrasonic vibration with different frequency is applied on the other plate. Reduction of residual stress is examined in this case.

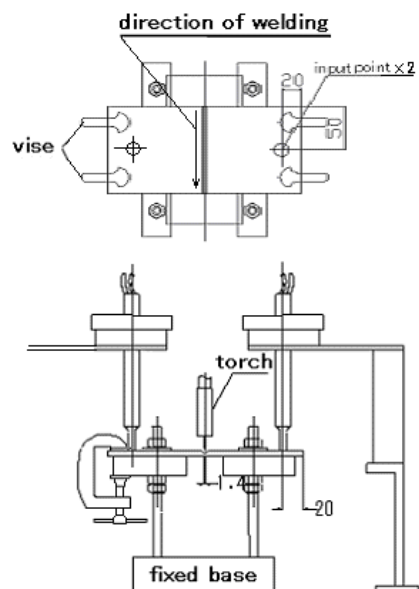

Fig. 1. Set of specimens (mm)

Size of specimen is 100mm square and 6mm thick. Material of specimen is the rolled steel for general structure (JIS SS400). In order to eliminate residual stress induced by rolling, it was annealed at 900°C for one hour and cooled in a furnace until it was 200°C. The groove is V-shaped and the groove angle is 45°. Root opening is 1.7mm. Two thin plates are hold onto the supporting device as shown in Fig.1 and shaken by ultrasonic vibration during welding. Specimens are welded using an

automatic acid gas shielded arc welding machine. Welding is completed through one pass. Ultrasonic vibrator is put on the center line and 20mm from edge of each thin plate. Frequencies of ultrasonic vibration are 50kHz and 27.5kHz. Output is 100W. The natural frequency of specimen before welding is 36Hz. For comparison, some specimens are welded using one ultrasonic vibration on one plate. Some specimens are welded without vibration. Welding speed is 3.75mm/s. Welding is completed in 27second. Diameter of wire is 0.9mm. Voltage is 21V and current is 200A.

Residual stress is measured using X-ray diffractometer with a scintillation counter after removing quenched scale chemically using hydrochloric acid having a concentration of 6mol/l and smoothing surface of the bead using CPL (chemical polishing liquid). Residual stresses are measured at 9 points on the bead and at 11 points on the center line perpendicular to the bead. Residual stresses in direction of the bead are measured.

Fig. 2 shows residual stresses on the bead. ○ shows residual stresses of specimen welded without ultrasonic vibration. □ shows residual stress using 60kHz ultrasonic vibration on one plate. ● shows residual stress using 27.5kHz ultrasonic vibration on one plate. ■ shows residual stress using 60kHz ultrasonic vibration on one plate and 27.5kHz ultrasonic vibration on the other one plate. Tensile residual stresses are measured at almost of all points. Especially, high tensile residual stress is measured at center of the bead. When ultrasonic vibration is applied on one plate, tensile residual stress is significantly reduced at center of the bead. In this case, the effect of frequency on reduction of residual stress is not

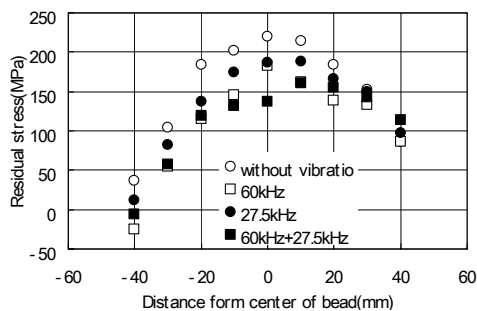

Fig. 2. Residual stress on the bead

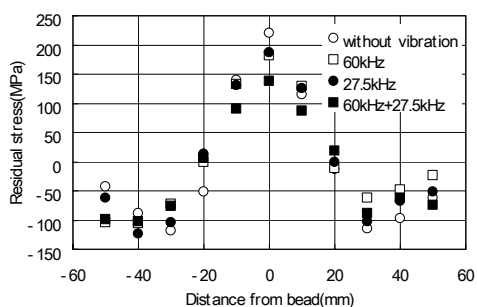

Fig. 3. Residual stress in longitudinal direction

different for 60kHz and 27.5kHz. On the other hand, when ultrasonic vibrations are applied on both plates, reduction rate is greater than one excitation.

Fig. 3 shows residual stress on the line perpendicular to the bead. Tensile residual stresses are measured near the bead. When ultrasonic vibration is used, residual stress is reduced near the bead. Especially, when ultrasonic vibrations with different frequencies are used on both plates, reduction rate of residual stresses is great.

Welding with ultrasonic vibration and low frequency vibration

When thin plates are butt-welded, ultrasonic vibration is applied on one plate and low frequency vibration with natural frequency of the specimen is applied under the plates. Reduction of residual stress is examined.

Size of the specimen is same as welding with ultrasonic vibrations with different frequencies. Ultrasonic vibration is used on one plate and low frequency vibration is used on both plates. Low frequency vibration is applied on both plates by the shaker under the plates. The natural frequency of the specimen before welding is 35Hz. Then, vibration with 35Hz is applied below the plate. Frequency of ultrasonic vibration is 60kHz.

Fig. 4 shows residual stresses on the bead. ○ shows residual stress of specimen welded without ultrasonic vibration. △ shows residual stress using 60kHz ultrasonic vibration on one plate. ▲ shows residual stress using low frequency vibration with 35Hz on both plates. ● shows residual stress using 60kHz ultrasonic vibration on one plate and low frequency vibration with 35Hz on both plates. When vibration is applied on one plate, tensile residual stress is reduced at center of the bead. Especially, when ultrasonic vibration is applied on one plate and low frequency vibration is applied on both plates, reduction rate of residual stresses is great.

Welding of wheel

Proposed method is applied to welding of structure with curve and complicated shape. An example of such structure, wheel is used.

Diameter of wheel is 329.4mm. Disk is inserted into limb with 2000N force. 4 locations inside of the wheel are welded. After disk is inserted, ultrasonic vibration is used during welding. Fig. 4 shows set of wheel. Wheel is fixed on the turntable of positioner. Angle of the turntable is 45°. Angle of location of the horn transmitting ultrasonic vibration and that of welding is 90°. Inside of the wheel is welded using ultrasonic vibration from outside rotating the wheel. Shape of tip of horn is spherical and tip of horn is touches wheel at a point. Horn pushed by air cylinder always touches wheel during rotation. Pressure of air cylinder is 0.1MPa and press force is 80N.

Fig. 5 shows measuring locations of residual stress. Residual stresses are measured every 20mm at 5 points of each location from outside of wheel (opposite side of the bead). First, locations a and c are welded without

ultrasonic vibration. Then, locations b and d are welded using ultrasonic vibration. Amplitude of tip of horn is $19\mu\text{m}$.

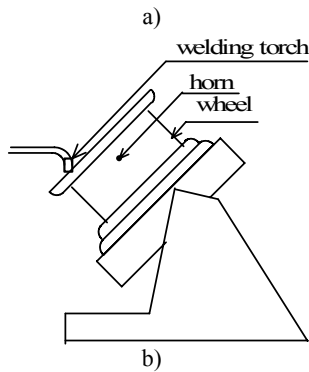
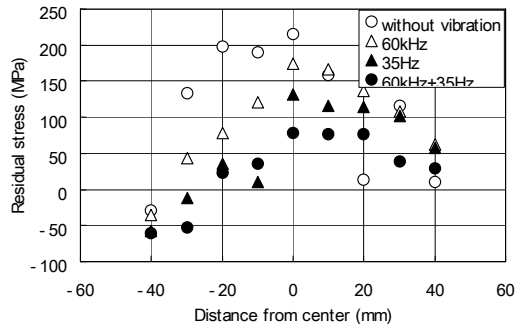

Fig. 4. Welding: a – residual stress on the bead, b – set of wheel

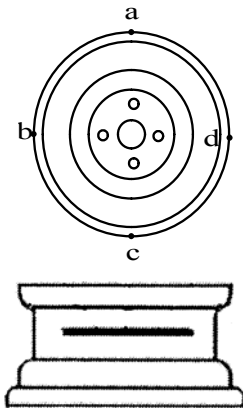

Fig. 5. Measuring locations of residual stress on wheel

Table 1 shows results. Bottom low shows average of residual stresses. Tensile residual stresses are reduced at almost of all points. When ultrasonic vibration is used during welding, tensile residual stress is reduced by 20-30%.

Table 1. Residual stress (MPa)

Position	Without vibration		With vibration	
	a	c	b	d
A	150	120	150	120
B	120	110	100	90
C	110	100	100	30
D	140	90	80	70
E	50	100	50	50
Average	114	104	96	72

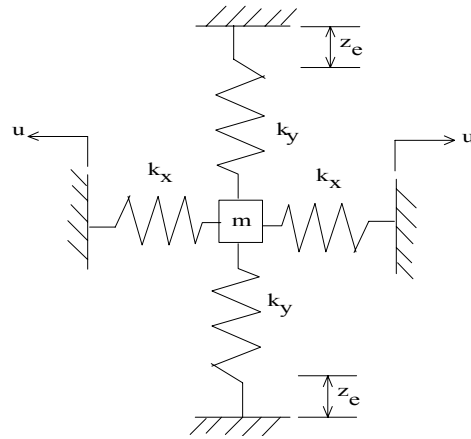

Fig. 6. Two dimensional model

Analytical method

Yield stress of metal immediately after welding is very low. It is considered that permanent deformation can be generated by very low external load. In this analysis, reduction of tensile residual stress on the bead of thin plate is dealt with using two-dimensional model. Since specimens are thin plates, plane stress state is considered. Hence, an analytical model shown in Fig.6 is used considering actual stresses in plane. x-axis is longitudinal direction of the specimen, direction of surface vibration, and y-axis is transverse direction of the specimen, direction of the bead. As shown in Fig.6, springs in transverse direction are extended by Z_e from the equilibrium position. In this case, $k_y Z_e$ is residual stress without ultrasonic vibration. It is assumed that restoring force-deformation relation of the springs is represented by the perfectly-elasto-plastic model. Accordingly, when stresses in x-axis and y-axis are considered to be principal stresses, it is assumed that springs are yielding according to Tresca yield criterion. This model is excited in x-axis.

Residual stress with surface vibration is evaluated as:

$$\sigma_{sy} = k_y (Z_e - Z_{py}), \quad (1)$$

where Z_{py} is sum of plastic deformation in y-axis.

Ratios of residual stress calculated by using ultrasonic vibration to that without vibration are obtained. In Table 2, results for 60kHz ultrasonic vibration are shown. F_y is yield force for uniaxial stress. Ratios are less than 1 in all conditions. This means that residual stress is reduced when ultrasonic vibration is used during welding.

In Table 3, results are shown when ultrasonic vibrations with 60kHz and 27.5kHz simultaneously. Ratios in Table 3 are less than that in Table 2. From Table 3, it is found that reduction rate is great when ultrasonic vibrations with 60kHz and 27.5kHz simultaneously.

Let m be mass of the bead, ratios of residual stress decrease with decrease of F_y/mU , that is, increase of amplitude of excitation U . This means that residual stress decreases with the increase of amplitude of excitation. Reduction rate increases with the increase of $k_y Z_e/F_y$, that is, with the increase of residual stress without ultrasonic vibration.

Table 2. Ratio of residual stress with ultrasonic vibration to that without ultrasonic vibration (60kHz)

$k_y Z_c / F_c$	F_y / mU			
	0.0010	0.0012	0.0014	0.0016
0.9	0.720	0.781	0.824	0.856
0.8	0.776	0.839	0.882	0.913
0.7	0.827	0.891	0.924	0.964

Table 3. Ratio of residual stress with ultrasonic vibration to that without ultrasonic vibration (60kHz+27.5kHz)

$k_y Z_c / F_c$	F_y / mU			
	0.0010	0.0012	0.0014	0.0016
0.9	0.302	0.435	0.530	0.601
0.8	0.325	0.471	0.574	0.651
0.7	0.340	0.501	0.614	0.696

4. Conclusions

The effect of vibrations with different frequencies on reduction of residual stress is examined. Firstly, two thin plates are butt-welded using ultrasonic vibrations with

different frequencies on each plate. When thin plates are welded using ultrasonic vibrations with different frequencies, tensile residual stresses are reduced and reduction rate is largest compared with other conditions. Secondly, two thin plates are butt-welded using ultrasonic vibration and vibration with low frequency. In this case, tensile residual stresses are reduced and reduction rate is largest compared with other conditions. Thirdly, a welding of automobile wheel for automatic welding system is performed using ultrasonic vibration. As a result, it is confirmed that residual stress is reduced. Finally, experimental results are examined by analytical method.

References

1. **Burst F. W., Scot P. M., Yang Y.** Weld Residual Stress and Crack Growth in Bimetallic Pipe Welds // Trans. of 17th International Conference on Structural Mechanics in Reactor Technology, -2003, G08-1
2. **Frost N. E., Marsh K. J., Pook L. P.** Metal Fatigue, Dover, 1999.

Submitted for publication 2007 02 15

S. Aoki, S. Hirai, V. Saechout, M. Kohmura, T. Nishimura, T. Hiroi. Development for Automatic Welding System with Reduction of Residual Stress. - Effect of Vibrations with Different Frequencies // *Electronics and Electrical Engineering*. - Kaunas: Technologija, 2007. - No. 4(76). - P. 21-24.

Development of automatic welding system is an important problem for automatic manufacturing system. It is well known that residual stress is measured near the bead because base metal is heated near the bead. Tensile residual stress on the surface degrades fatigue strength. In this paper, the effect of vibrations with different frequencies on reduction of residual stress is examined. Firstly, two thin plates are butt-welded using ultrasonic vibrations with different frequencies on each plate. When thin plates are welded using ultrasonic vibrations with different frequencies, tensile residual stresses are reduced and reduction rate is largest compared with other conditions. Secondly, two thin plates are butt-welded using ultrasonic vibration and vibration with low frequency. In this case, tensile residual stresses are reduced and reduction rate is largest compared with other conditions. Thirdly, a welding of automobile wheel for automatic welding system is performed using ultrasonic vibration. As a result, it is confirmed that the reduction of residual stress is reduced. Lastly, reduction of tensile residual stress is demonstrated using an analytical model based on elasto-plastic characteristic. Il. 6, bibl. 2 (in English; summaries in English, Russian and Lithuanian).

С. Аоки, С. Гирай, В. Саехоут, М. Кохмура, Т. Нишимура, Т. Гирой. Уменьшение остаточных напряжений при применений автоматических устройств сварки // *Электроника и электротехника*. - Каунас: Технология, 2007. - № 4(76). - С. 21-24.

Анализируются остаточные напряжения, создающиеся при применении автоматических устройств сварки. Исследовано влияние частоты сварки на разные сварочные конструкции. Показано насколько разные частоты ультра-звукова влияют на качество сварки конструкции из двух пластинок. Эксперименты, проведены для автомобильных деталей с использованием автоматических ультразвуковых сварочных систем. Выполнены расчеты напряжений для сварочных систем и даны рекомендации для решения практических задач. Ил. 6, библи. 2 (на английском языке; рефераты на английском, русском и литовском яз.).

S. Aoki, S. Hirai, V. Saechout, M. Kohmura, T. Nishimura, T. Hiroi. Liekamųjų įtempimų sumažinimas naudojant automatinę suvirinimo sistemą. Skirtingų dažnių vibracijų įtaka. // *Elektronika ir elektrotechnika*. - Kaunas: Technologija, 2007. - Nr. 4(76). - P. 21-24.

Išnagrinėti liekamieji įtempiai, susidarantys naudojant automatinę suvirinimo įrangą. Ištirtas įvairaus dažnio poveikis įvairiems suvirintiems gaminiams. Tyrimams atlikti buvo virinamos dvi plokštelės, veikiamos skirtingo dažnio ultragarsu, ir dvi plokštelės, veikiamos vienodo dažnio ultragarsu. Automobilio ratlankiui suvirinti panaudota automatinė ultragarsinė virinimo sistema. Atlikta šių struktūrų įtempimų analizė. Il. 6, bibl. 2 (anglų kalba; santraukos anglų, rusų ir lietuvių k.).

DOI: 10.5755/j02.eie.10709