

The Compressor Station Output Sharing System Structures

J. Šípál

Department of Machines and Mechanics, University of Jan Evangelista Purkyně in Ústí nad Labem, Ústí nad Labem, Czech Republic, phone: +420 475 285 515; e-mail: sipal@fvtm.ujep.cz

Introduction

Industrial companies, namely in power engineering, necessarily deal with the plants, being so designed in order to limit their drop-outs, i.e. that their redundancy must be fully guaranteed. That means that more installations of the same performance work in certain parallel connection. As an example we can mention feeding and vacuum pumps, cooling fans and compressors.

In these shunt connections it is not possible, very often, to determine exactly their time and output loading and the length of operation time service under load. Namely, it proved to be the case of compressors in compressor stations.

In the frame of the project “Tandem”, as announced by the Czech Ministry of Industry and Trade, there is a proposed solution of this problem by means of integrated calculation algorithms. At present, the team of projectors has finished the basic theoretical preparation of the project and begins the transposition of the theory into application calculation algorithms. These algorithms ensure accurate registration of operating time, including this plant time and power loading calculation. These calculation algorithms will be introduced into industrial control systems of the PLC/PAC category.

These, this way calculated results can be transferred to the company higher-rank management computed network. The company operator receives so the detailed summary sheet on the running, loading and technical state of all machinery. The information can be then used for planning of production and servicing to minimize both, breakdowns of production capacities and systematic maintenance costs.

This contribution should illustrate one possible way of usage of industrial computing system for determination of specific loading of each aggregate in compressor station. Plant operator can use the collected diagnostic information for an assessment of the machinery state to ensure stable service of the production equipment. The authors acquaint the readers with the solution of the theoretical part of the project. The following stages will be focused on the

algorithms implementation into PLC/PAC and in practical testing on the real plant.

Application on the Compressor Station

Compressor station is a typical representant of equipment operating in parallel. In industrial companies it is nearly always an auxiliary plant, where the supply of compressed air is necessary to ensure the main production.

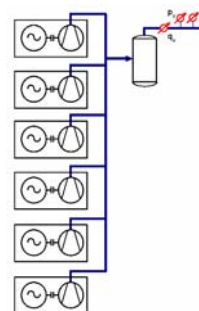

Fig. 1. Compressor Station Outline

There is an outline of a compressor house – Fig. 1 being equipped with six compressors. During the service the particular aggregate is either in service or shutdown. The loading, the compressed air take-off are so distributed that the servicing compressors are loaded intermittently. Different conditions of operation may happen during the involved time. They are – the length of ordinary service, shutdown and so called momentary reserve, which means that machine is in no load operation and covers then the peak consumption curve, being alternatively loaded. The compressor load is controlled by means of the compressed air distribution piping pressure drop. The special service state may occur, when, e.g. the sole electromotor is tested and the driven machine is decoupled and only power supply switches and current protections are inspected. These sporadic cases will not be solved by this project arrangement. Usually the plant operator is not able to Fig. 1 find out any information about particular machine being in service for certaintime. This information is namely

about: the time of its operation under the load, an average load of given machine, etc. Later on, these data may serve for a forecast of wear and tear of the machine and its service economy and can be gained through the calculation algorithms being implemented into PLC/PAC, becoming so the accessory of the compressor station.

Particular Machine Load Detection

Input signals are processed by the PLC/PAC implemented calculation algorithms. The following may be input signals, being measured and sensed at the compressor station:

- measured flow rate q_v in standard cubic meters per second [Nm^3s^{-1}] – in the case that the station output is equipped with the compressed air volume measurement.
- If there is not installed a.m. volume registration it is necessary to measure the output temperature Θ_v [K], pressure p_v [MPa] and compressed air flow velocity v_v [ms^{-1}]. Then, the flow rate q_v [Nm^3s^{-1}] is easy to calculate and this computing simple algorithm can be implemented into the automat.
- temperature Θ_i compression pressure p_i at the output of the i -th compressor
- the i -th compressor electromotor current I_i [A]
- the i -th compressor logical variable M_i , describing the state of power switch
- the i -th compressor logical variable K_i , describing the state of its relief (by pass) valve
- consumed electrical energy I_{ost} [A], eventually the water for a plant ensuring for example, central cooling station for all compressors

We can see the i -th compressor equipment and the compressor station outline at Fig.2. It is necessary to relate all the measured values to a time axis, to have possibility to analyze the data as the time series. The measured data represent the state vector, describing the state of particular compressor.

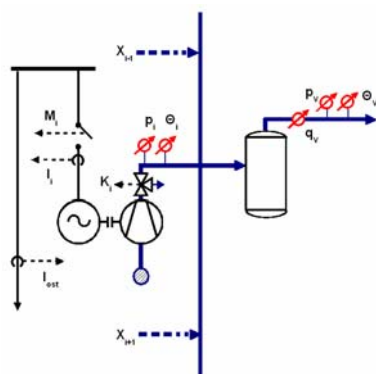

Fig. 2. Schematic of measurement

Shut down aggregate is characterized by electromotor zero feed current and the supply switch being switched-off. After the switch being switched-on, the motor element starts to run and the current will grow. This switch state will be signalled with accessory contacts – it is logical value “true”. This logical value change occurs always in certain time interval controlling so regular alternation. The second supervised value is the drive

electromotor current. There is a current steep increase at the beginning, followed by the decrease, when the revolutions reaches the nominal value. In accordance with the motor start in characteristic there is the second current increase in the moment of wye-delta switching. [1] The measured value of the current is decisive to indicate whether the aggregate is run under the load or off-load. The mentioned case, the testing of the electromotor itself, without the driven compressor is characterized by quick starting, short time interval to the reach of the nominal revolutions, which are higher than that of the machine set.

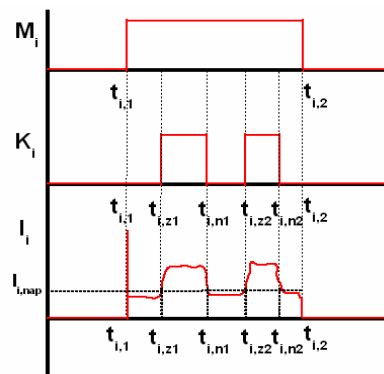

Fig. 3. Current-time dependency

Switching on the i -th machine in the time $t_{i,1}$ [s], this time is registered by the logical variable M_i , which reaches the quantity 1. The machine starts to run, after certain time the transient process finishes and the electromotor current becomes leveled. The time dependency of current in the graph Fig.3 is divided into three sections, according to the kind of the aggregate operation. The first section, when the motor does not run, is characterized by the state $M_i=0$ and the current $I_i=0$. The second section, when the motor runs, any load is described by combination $M_i=1$ and $K_i=0$. The current I_i corresponds to the value $I_{i,nap}$. It is the mode when the compressor is unloaded. The third section is the section of loading, during which the compressor supplies the compressed air into the system. This section is given by combination $M_i=1$ and $K_i=1$. These operation states of the i -th machine unit are arranged in the following table.

M_i	K_i	I_i	Operating state
0	0	$I_i = 0$	Shut down machine
1	0	$I_i \approx I_{i,nap}$	Off-load run
1	1	$I_i \triangleright I_{i,nap}$	Run under load

The following constant must be included into data processing system, for each aggregate: $I_{i,nap}$ nominal off-load run current

The nominal off-load run current changes during the time, because of wear and tear of machine parts. Its value grows. By virtue of logical variables M_i and K_i combination the automat determines the kind of the whole unit service and may so assign the real value $I_{i,nap}$. Value $I_{i,nap}$ monitoring enables the plant operator to evaluate the technical condition of the machine unit.

Ordinary service of the compression station is characterized by the fact that one or more compressors work under the load. It does not mean that they are loaded by nominal load. Others operate as the reserve and the rest is shut-down. The reserve means that they are in operation and are loaded automatically, in accordance with the need to cover the peak consumptions of the output curve. Machine units are so changing periodically during the service.

If we know the state vectors of all machines we can start the load calculations for each machine. Then, amperage difference of the loaded machine is measured during the time intervals. This time difference will serve as the distribution parameter of the produced pressure air.

$$\Delta I_i = I_i - I_{i,nap} \quad [A], \quad (1)$$

where I_i [A] – for the i -th compressor electromotor current, $I_{i,nap}$ [A] – the i -th electromotor adjusted constant of off-load run current, ΔI_i [A] – the i -th electromotor amperage difference.

The total production of the compressed air flow rate q_v is measured continually. This production is composed of all compressors contributions

$$q_v = \sum_{i=1}^n q_{vi} \quad \left[\frac{Nm^3}{s} \right]. \quad (2)$$

The produced compressed air is necessary to divide between all machines in the way, fulfilling the equation (2). We can use so called methods of ratios. In the compression station, the compressed air produced with one aggregate of the same design is then calculated from the formula (3). For the less common case of different design compressors installation is essential to use the weighting, according to the real configuration of the compressor station

$$q_{v,i} = \frac{q_v \frac{p_v \Theta_i K}{p_i \Theta_v}}{\sum_{i=1}^n \Delta I_i} \Delta I_i \quad \left[\frac{Nm^3}{s} \right], \quad (3)$$

where q_{vi} [$Nm^3 \cdot s^{-1}$] – the i -th compressor output flow rate, q_v [$Nm^3 \cdot s^{-1}$] – the compression station flow rate, p_v [MPa] the compressed air output pressure, Θ [K] – the compressed air output temperature, p_i [MPa] – the i -th compressor output pressure, Θ_i [K] – the i -th compressor output temperature, K [1] – ration of compression.

Due to the wear and tear of the aggregate the given compressor has larger consumption of energy for production of the same volume of compressed air. This situation would be the cause of the error when using the calculation formula (3). This inaccuracy can be removed when monitoring and ensuring the proportionate loading of all machines. It results in even amortization of all compressors in the station and the ration in the equation (3) remains practically without any change.

Integration of the gained data for a certain interval of time enables the calculation of the produced compressed air volume Q_{iv} for each compressor. From the total production during the time interval of loaded compressor

$t_{i,zat}$ we can calculate the average output q_{iv} and this can be compared with the compressor nominal output. The result is the utility factor of the machine:

$$Q_{iv} = \int_t q_{v,i} dt \quad [Nm^3], \quad (4)$$

$$\overline{q_{iv}} = \frac{Q_{iv}}{t_{i,yat}} \quad \left[\frac{Nm^3}{s} \right]. \quad (5)$$

The other parameter may be the calculated specific energy consumption per one standard cubic meter of compressed air

$$w_i = \sqrt{3} U_{sdr} \int_t \frac{(I_i + I_{i,ost})}{q_{iv}} dt \quad \left[\frac{J}{Nm^3} \right]. \quad (6)$$

Parameter $I_{i,ost}$ is calculated by weighing of I_{ost} between particular machines, acc. to I_i .

Systematic archiving of switching on and shut-down times, and in both directions set up values of no-load current, enables the easy calculation of the whole time of the machine run, service under the load and calculation of the aggregate time usage:

$$\tau_{i,zat} = \frac{T_{i,zat}}{t} 100 \quad [\%], \quad (7)$$

$$\tau_{i,nap} = \frac{T_{i,nap}}{t} 100 \quad [\%], \quad (8)$$

$$\tau_{i,0} = \frac{T_{i,0}}{t} 100 \quad [\%], \quad (9)$$

where $t_{i,zat}$ [s] – the compressor service time under load, $t_{i,na}$ [s] – the compressor off-load run time, $t_{i,0}$ [s] – the compressor shut down time.

The quantities calculated from formulas (3) to (9) and the value of measured current $I_{i,nap}$ create a sufficient data file for mutual comparison of compressors loading, for planning of their performance and for their maintenance condition analysis.

The Load Distribution Flow Sheet

These relations can be easily visualized by means of the flow sheet – Fig.4. The block diagram basically explains the PLC/PAC activity, where its programming is the project objective.

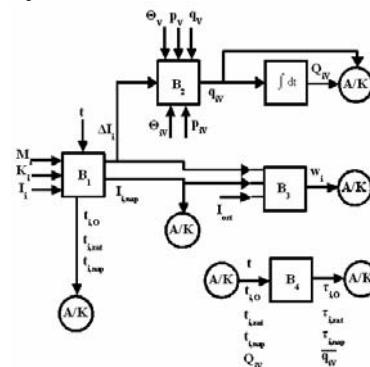

Fig. 4. Block diagram

The whole process is graphed in blocks, having the same time synchronization. Index i designates the quantity

of the i -th compressor. Arrows with i indexed quantities denotes the vectors, bearing the information on all compressors.

Block B₁ is a block, registering logical input quantities M_i and K_i and motor input currents I_i . This block determines time quantities $t_{i,zat}$ - the compressor service time under load, $t_{i,nap}$ - the compressor off-load run time and $t_{i,ods}$ - the compressor shut down time. The other group of output signals are current signals, ΔI_i - on load current (1), and $I_{i,nap}$ - off load compressor run current.

Block B₂ calculates the production of pressured air on particular compressors. One machine whole production we obtain by integration.

Block B₃ determines specific energy consumption per one standard cubic meter of compressed air on one engine.

Block B₄ in contrast to previous ones, does not work in real time, but supplies the operator with information, describing the monitored period of time. This block determines the relative load of aggregates for predetermined period of time, based on archived information (e.g. per one day).

Block A/K is a block, archiving all the measured and calculated values. From those information it is able to calculate the tendencies, being important namely for specific energy consumption. The processed results are transmitted for other procession into the management computer network.

Conclusion

The particular machine wear and tear is a result of their loading and overloading. By means of PLC/PAC implemented calculation algorithms the plant operator obtains the information about the operation of particular

compressor in the station. The calculated time and output loadings including specific energy consumption and their tendencies is certain indicator of the machine amortization.

Therefore, it is possible to optimize the planning of the compressors operational maintenance, saving maintenance capacities and costs – everything being based on this proposed automat information. This automat proposal completes the first, theoretical stage of our project.

The production of system prototype, monitoring, evaluating and registering the production of compressed air on particular machines is the project second stage, which we have just started.

Acknowledgement

This research is supported with the help of the project, number FT-TA3/155 in the programme “Tandem”, being announced by the Ministry of Industry and Trade of the Czech republic.

References

1. **Bohumil S.** Proud asynchronního stroje při různých druzích rozběhu a skokové změně zatížení; ZČU fakulta elektrotechnická Czech Republic, 2006. Výzkumná zpráva č. 22160-32-06.
2. **Oto S.** Programovatelné automaty a metematické programy; magazine Automatizace 2003, Prague Czech Republic.

Submitted for publication 2007 02 08

J. Šípal. The Compressor Station Production Sharing System Structures // Electronics and Electrical Engineering. – Kaunas: Technologija, 2007. – No. 4(76). – P. 17–20.

Parallel working devices are relatively often used in real industrial production. Unfortunately, in many cases, e. g. compressor station, it is rather difficult to determine the load of every single machine. On the other hand, this is a important information for the production management, because such a piece of information may allow to divide the load equally among all machines. Equally divided load reduces the unexpected failures of single machines due to performance over its limits. Moreover, it stimulates the efficiency of the whole production process. This article presents algorithm, which is according to some basic measurements capable of determining the load of every single compressor in a compressor station. In the future an industrial computer with such an algorithm will be an equipment of a compressor station. Data from this computer should become a significant help to the production management. Ill. 4, bibl. 2 (in English; summaries in English, Russian and Lithuanian).

Ю. Шипал. Структуры воздушных компрессорных систем управления // Электроника и электротехника. – Каунас: Технология, 2007. – № 4(76). – С. 17–20.

Описывается алгоритм систем управления при помощи которого легко рассчитывается разные нагрузки компрессоров. Указывается, что сегодня очень трудно установить оптимальные условия работы отдельных компрессоров. Предлагается методика учета нагрузки для отдельных компрессоров в собретенных сложных сетях управления. Найдены оптимальные условия снижения вероятности отказов. Ил. 4, библи. 2 (на английском языке; рефераты на английском, русском и литовском яз.).

J. Šípal. Oro kompresorinių sistemų valdymo struktūros // Elektronika ir elektrotechnika. – Kaunas: Technologija, 2007. – Nr. 4(76). – P. 17–20.

Išanalizuotas kompresorinių sistemų algoritmas, kuriuo naudojantis galima apskaičiuoti kiekvieno kompresoriaus apkrovimą. Ateityje ši algoritmą planuojama pritaikyti praktikoje kompresoriams valdyti. Lygiagrečiai dirbantys įrenginiai yra dažnas reiškinys pramonėje. Daugeliu atvejų, pvz., oro kompresorinėse stotyse sunku atskirai nustatyti kiekvieno kompresoriaus apkrovimą. Kita vertus vienam kompresoriui tenkantį krūvį galima gauti padalijus reikiamą krūvį iš kompresorių skaičiaus. Šitai sumažinama gedimų tikimybė. Il. 4, bibl. 2 (anglų kalba; santraukos anglų, rusų ir lietuvių k.).

DOI: 10.5755/j02.eie.10708