

## Computer Aided Design on Oscillating Drives

A. Brazaitis, E. Guseinoviėnė

Department of Electrical Engineering, Klaipėda University,  
Bijūnų str. 17, LT-91225 Klaipėda, Lithuania, phone: +370 46 398686,  
e-mails: eleonora.guseinoviene@ku.lt, elektra@jtf.ku.lt

### Introduction

In area of oscillating electrical drives in all known research works, including the authors' of this article, there is one common feature – there is analyzed a drive with single case of a motor [1, 2]. Therefore in individual case of the same subject of research it is needed to create different mathematical model. So, mathematical models of reaction and pulsating current motors appear which also have a lot of different mathematical models, depending on different approximation function of permeance or separate forms of supplying voltage. Such problem solving method is expedient, when it is needed to find out common regularity of individual case of drive by using analytical methods, and absolutely unacceptable, when single case of a drive is analyzed by numerical methods [3, 4, 5].

The aim of this paper is formation and application of universal method of mathematical model of drives with oscillating motors.

### Research object and method

There are presented principles of formation of universal method of mathematical model of drives with oscillating motors applying formal methods, peculiarities of its application investigating these drives in numerical mode. The most universal construction of oscillating motor is pulsating current motor of symmetrical construction. Oscillating motors of all other well known constructions are obtained simplifying this construction. Therefore this type of motor is used when forming universal mathematical model.

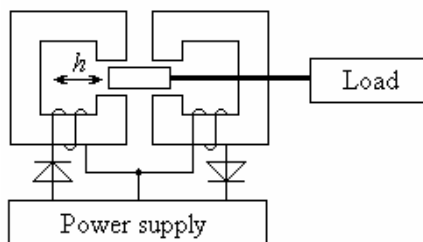

Fig. 1. Scheme of drive with oscillating motor

Symmetrical motor (Fig. 1) consists of two motors of asymmetrical construction. Point of view exists, that in process of investigation of drives with pulsating current motors of symmetrical construction it needs to be content with mathematical model of asymmetrical construction and the driving force of another motor is evaluated by increasing the driving force of the first one twice. Such way of solving of that task limits analysis of properties of drive. To start with work symmetrical motor oscillates around a center of oscillation. But the center of oscillations of asymmetrical motor makes a move. Therefore, the mathematical parameters which depend on coordinate  $h$  are changed with displacement of a center of oscillation. So, it is needed to input fictitious force to return oscillation center to the initial position. This solution is suitable only in steady-state regime and absolutely wrong in transient regime. Fictitious force has to stabilize a center of oscillation. But way of changing of this force in transient regime is unknown at all. Symmetrical mathematical model of drive allows analyzing influence of asymmetry of model to the drives characteristics.

Equation of balance of the first motor:

$$u = \frac{R_a + R_d}{R_a} \left( L \frac{di_L}{dt} + i_L \left( R_{ekv} + \frac{R_a R_d}{R_a + R_d} \right) \right) + u_n. \quad (1)$$

Equation of balance of the second motor:

$$u' = \frac{R'_a + R'_d}{R'_a} \left( L' \frac{di'_L}{dt} + i'_L \left( R'_{ekv} + \frac{R'_a R'_d}{R'_a + R'_d} \right) \right) + u'_n, \quad (2)$$

where  $u$  – supplying voltage,  $i_L$  – inductance current of a motor,  $R_a$  – resistance of a motor,  $R_d$  – resistance of losses of core,  $t$  – time,  $L$  – inductance of a motor's winding – function of coordinate  $h$  of a motor's mover

$$L = f(h), \quad (3)$$

where  $R_{ekv}$  – resistance, evaluating change of inductance of a motors,

$$R_{ekv} = \frac{dL}{dt}, \quad (4)$$

$u_n$  – voltage of non-linear element; it's a function of current of a motor

$$u_n = \Psi(i). \quad (5)$$

The parameters of a second motor in expression (2) are marked down with the same symbols as the first one, only with lines.

The driving force of the first motor is a function of a square of a current

$$f = \varphi(i_L^2) = \frac{1}{2} i_L^2 \frac{dL}{dh}. \quad (6)$$

The driving force of the second motor also is a function of a square of a current

$$f' = \varphi'(i_L'^2) = \frac{1}{2} i_L'^2 \frac{dL'}{dh}. \quad (7)$$

The equation of balance of a load of a motor

$$f = m \frac{d^2 h}{dt^2} + R_{mch} \frac{dh}{dt} + ch, \quad (8)$$

where  $m$  – mass of a mover,  $R_{mch}$  – resistance of this mover,  $c$  – rigidity of this mover.

Velocity of a mover

$$v = \frac{dh}{dt}. \quad (9)$$

Thus, the equation of balance of a load of a motor:

$$f = m \frac{dv}{dt} + R_{mch} v + \int cv dt. \quad (10)$$

This equation is analogous to a series LCR circuit, therefore due to succeeding community of expressions mechanical parameters can be written as general symbols of electrical ones

$$L_{mch} = m, \quad (11)$$

$$C_{mch} = \frac{1}{c}. \quad (12)$$

Substituting (9), (11) and (12) to the expression (8) it is obtained

$$f = L_{mch} \frac{dv}{dt} + R_{mch} v + \frac{1}{C_{mch}} \int v dt. \quad (13)$$

Thus equivalent resistance, that evaluates changing of inductance, can be written

$$R_{ekv} = v \frac{dL}{dh}. \quad (14)$$

Considering to (1), (5) and (13) diagram of a drive can be shown (Fig. 2). In this diagram functions (6) and (7) are treated as dependent source, its output voltage is marked down  $U_v$ :

$$U_v = \varphi(i_L^2) - \varphi'(i_L'^2). \quad (15)$$

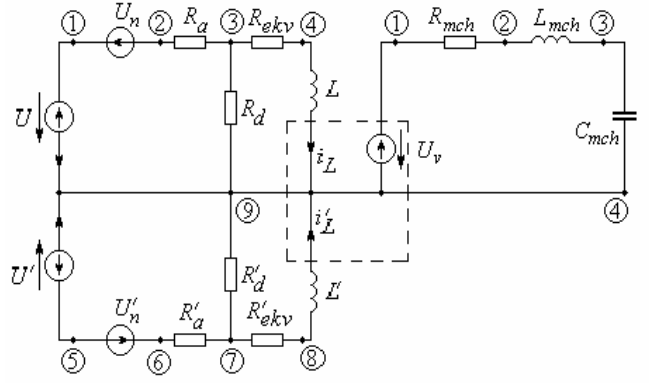

**Fig. 2.** Diagram of drive with oscillating motor

Topology of electrical and mechanical parts of symmetrical drive can be shown in Table 1.

**Table 1.** Topology of electrical and mechanical parts of symmetrical drive

Number of branch	Parameter	Branches	
		Beginning	End
1	$U_n$	1	2
2	$U'_n$	6	5
3	$U$	1	9
4	$U'$	5	9
5	$R_a$	2	3
6	$R_d$	3	9
7	$R_{ekv}$	3	4
8	$R'_a$	6	7
9	$R'_d$	7	9
10	$R'_{ekv}$	7	8
11	$L$	4	9
12	$L'$	8	9
1	$U_v$	1	4
2	$C_{mch}$	3	4
3	$R_{mch}$	1	2
4	$L_{mch}$	2	3

Matrices of the main incisions of electrical and mechanical parts

$$\mathbf{F} = \begin{matrix} & R_d & R'_d & L & L' \\ \begin{matrix} U_n \\ U'_n \\ U \\ U' \\ R_a \\ R_{ekv} \\ R'_a \\ R'_{ekv} \end{matrix} & \begin{bmatrix} -1 & 0 & -1 & 0 \\ 0 & 1 & 0 & 1 \\ 1 & 0 & 1 & 0 \\ 0 & 1 & 0 & 1 \\ -1 & 0 & -1 & 0 \\ 0 & 0 & -1 & 0 \\ 0 & -1 & 0 & -1 \\ 0 & 0 & 0 & -1 \end{bmatrix} & = & \begin{bmatrix} \mathbf{F}_{U_n R_s} & \mathbf{F}_{U_n L_s} \\ \mathbf{F}_{U'_n R_s} & \mathbf{F}_{U'_n L_s} \\ \mathbf{F}_{U R_s} & \mathbf{F}_{U L_s} \\ \mathbf{F}_{U' R_s} & \mathbf{F}_{U' L_s} \end{bmatrix}, \quad (16) \end{matrix}$$

$$\mathbf{F}_m = \begin{matrix} & & L_{mch} \\ U_v & \begin{bmatrix} 1 \\ -1 \end{bmatrix} \\ C_{mch} & \\ R_{mch} & \begin{bmatrix} -1 \\ -1 \end{bmatrix} \end{matrix} = \begin{bmatrix} \mathbf{F}_{U_v L_s} \\ \mathbf{F}_{C_b L_s} \\ \mathbf{F}_{m R_b L_s} \end{bmatrix}. \quad (17)$$

Expression (18) shows the blocs of main incisions; mathematical dependencies of the drive with symmetrical synchronous oscillating motor are written in equation system (19):

$$\begin{aligned} \mathbf{F}_{U_n R_s} &= \begin{bmatrix} -1 & 0 \\ 0 & 1 \end{bmatrix}, \quad \mathbf{F}_{U_n L_s} = \begin{bmatrix} -1 & 0 \\ 0 & 1 \end{bmatrix}, \\ \mathbf{F}_{U R_s} &= \begin{bmatrix} 1 & 0 \\ 0 & 1 \end{bmatrix}, \quad \mathbf{F}_{U L_s} = \begin{bmatrix} 1 & 0 \\ 0 & 1 \end{bmatrix}, \\ \mathbf{F}_{R_b R_s} &= \begin{bmatrix} -1 & 0 \\ 0 & 0 \\ 0 & -1 \\ 0 & 0 \end{bmatrix}, \quad \mathbf{F}_{R_b L_s} = \begin{bmatrix} -1 & 0 \\ -1 & 0 \\ 0 & -1 \\ 0 & -1 \end{bmatrix}, \\ \mathbf{F}_{U_v L_s} &= [1], \quad \mathbf{F}_{C_b L_s} = [-1], \quad \mathbf{F}_{m R_b L_s} = [-1] \end{aligned} \quad (18)$$

$$\begin{cases} \mathbf{i}_R = \mathbf{B}_1 \mathbf{x} + \mathbf{B}_2 \mathbf{x}_{ns} + \mathbf{B}_3 \mathbf{x}_n, \\ \frac{d\mathbf{x}}{dt} = \mathbf{A}_1 \mathbf{x} + \mathbf{A}_2 \mathbf{x}_{ns} + \mathbf{A}_3 \mathbf{x}_n + \mathbf{a}_4 u_v, \\ i_n = \mathbf{M}_1 \mathbf{x} + \mathbf{M}_2 \mathbf{x}_{ns} + \mathbf{M}_3 \mathbf{x}_n, \\ i_n = \phi(u_n), \\ u_v = f(i_L^2) - f(i_{L'}^2), \\ i_{R_{mch}} = i_{L_{mch}}, \end{cases} \quad (19)$$

where  $\mathbf{i}_R$ ,  $\mathbf{x}$ ,  $\mathbf{x}_{ns}$  ir  $\mathbf{x}_n$  – vectors of resistance currents, variables of mode, independence sources and non-linear resistances:

$$\mathbf{i}_R = \begin{bmatrix} i_{R_a} \\ i_{R_{ekv}} \\ i_{R'_a} \\ i_{R'_{ekv}} \\ i_{R_d} \\ i_{R'_d} \end{bmatrix}, \quad (20)$$

$$\mathbf{x} = \begin{bmatrix} u_{C_{mch}} \\ i_{L_{mch}} \\ i_L \\ i_{L'} \end{bmatrix}, \quad (21)$$

$$\mathbf{x}_{ns} = \begin{bmatrix} u \\ u' \end{bmatrix}, \quad (22)$$

$$\mathbf{x}_n = \begin{bmatrix} u_n \\ u'_n \end{bmatrix}. \quad (23)$$

Coefficients-matrices of resistance currents can be written:

$$\mathbf{B}_1 = \mathbf{A}_{11}^{-1} \begin{bmatrix} \mathbf{0} & -\mathbf{F}_{R_b L_s} \\ \mathbf{0} & \mathbf{0} \end{bmatrix}, \quad (24)$$

$$\mathbf{B}_2 = \mathbf{A}_{11}^{-1} \begin{bmatrix} \mathbf{0} \\ \mathbf{F}_{U R_s}^T \end{bmatrix}, \quad (25)$$

$$\mathbf{B}_3 = \mathbf{A}_{11}^{-1} \begin{bmatrix} \mathbf{0} \\ \mathbf{F}_{U_n R_s}^T \end{bmatrix}, \quad (26)$$

$$\mathbf{A}_{11} = \begin{bmatrix} \mathbf{E} & \mathbf{F}_{R_b R_s} \\ -\mathbf{F}_{R_b R_s}^T \mathbf{R}_b & \mathbf{R}_s \end{bmatrix}. \quad (27)$$

Coefficients-matrices of mode equation:

$$\mathbf{A}_1 = \mathbf{A}_{21}^{-1} \left( \begin{bmatrix} \mathbf{0} & \mathbf{0} \\ \mathbf{F}_{R_b L_s}^T \mathbf{R}_b & \mathbf{0} \end{bmatrix} \mathbf{B}_1 + \begin{bmatrix} 0 & -\mathbf{F}_{C_b L_s} & \mathbf{0} \\ \mathbf{F}_{C_b L_s}^T & \mathbf{F}_{m R_b L_s}^T R_{mch} & \mathbf{0} \\ \mathbf{0} & \mathbf{0} & \mathbf{0} \end{bmatrix} \right), \quad (28)$$

$$\mathbf{A}_2 = \mathbf{A}_{21}^{-1} \left( \begin{bmatrix} \mathbf{0} & \mathbf{0} \\ \mathbf{F}_{R_b L_s}^T \mathbf{R}_b & \mathbf{0} \end{bmatrix} \mathbf{B}_2 + \begin{bmatrix} \mathbf{0} \\ \mathbf{F}_{U L_s}^T \end{bmatrix} \right), \quad (29)$$

$$\mathbf{A}_3 = \mathbf{A}_{21}^{-1} \left( \begin{bmatrix} \mathbf{0} & \mathbf{0} \\ \mathbf{F}_{R_b L_s}^T \mathbf{R}_b & \mathbf{0} \end{bmatrix} \mathbf{B}_3 + \begin{bmatrix} \mathbf{0} \\ \mathbf{F}_{U_n L_s}^T \end{bmatrix} \right), \quad (30)$$

$$\mathbf{a}_4 = \mathbf{A}_{21}^{-1} \begin{bmatrix} 0 \\ \mathbf{F}_{U_v L_s} \\ \mathbf{0} \end{bmatrix}. \quad (31)$$

Matrices of parameters of scheme of a drive:

$$\mathbf{A}_{21} = \begin{bmatrix} C_{mch} & 0 & 0 & 0 \\ 0 & L_{mch} & 0 & 0 \\ 0 & 0 & L & 0 \\ 0 & 0 & 0 & L' \end{bmatrix}, \quad (32)$$

$$\mathbf{R}_b = \begin{bmatrix} R_a & 0 & 0 & 0 \\ 0 & R_{ekv} & 0 & 0 \\ 0 & 0 & R'_a & 0 \\ 0 & 0 & 0 & R'_{ekv} \end{bmatrix}, \quad (33)$$

$$\mathbf{R}_s = \begin{bmatrix} R_d & 0 \\ 0 & R_d' \end{bmatrix}. \quad (34)$$

Coefficients-matrices of non-linear equation can be written:

$$\mathbf{M}_1 = \begin{bmatrix} \mathbf{0} & -\mathbf{F}_{U_n R_s} \end{bmatrix} \mathbf{B}_1 + \begin{bmatrix} \mathbf{0} & -\mathbf{F}_{U_n L_s} \end{bmatrix} \quad (35)$$

$$\mathbf{M}_2 = \begin{bmatrix} \mathbf{0} & -\mathbf{F}_{U_n R_s} \end{bmatrix} \mathbf{B}_2, \quad (36)$$

$$\mathbf{M}_3 = \begin{bmatrix} \mathbf{0} & -\mathbf{F}_{U_n R_s} \end{bmatrix} \mathbf{B}_3. \quad (37)$$

Formation of matrices of vectors of non-linear functions:

$$\mathbf{i}_{U_n} = \phi(\mathbf{x}_n). \quad (38)$$

### Peculiarities of application of mathematical model

In process of design and analysis of drives with symmetrical motors the formed universal mathematical model has to be applied in all extent. Applying this model to the drives with asymmetrical pulsating current motors the element  $u'$  of the vector  $\mathbf{x}_{ns}$  of an independent source has to be equal zero; in case of reaction motor which has an asymmetrical construction, nay,  $\mathbf{x}_n$  has to be equal zero.

### Specific of program of mathematical model

Inductance (3) of winding of a motor is function of coordinate  $h$  of mover and equivalent resistance (14) depends on velocity of mover as well as on rapidity of changing of inductance, when coordinate  $h$  is changing.

**A. Brazaitis, E. Guseinoviėnė. Computer Aided Design on Oscillating Drives // Electronics and Electrical Engineering. – Kaunas: Technologija, 2006. – No. 6(70). – P. 19–22.**

This paper deals with the principles of formation and investigation of mathematical model of drives with oscillating motors. In individual case of the same subject of research it is needed to create different mathematical model. Many mathematical models of different kind of motors are obtained which contribute to a lot of a different kind of mathematical models depending of changing parameters of a motor. The principle of formation and application of universal mathematical model for drives with oscillating motors is proposed. Ill. 2, bibl. 5 (in English; summaries in English, Russian and Lithuanian).

**A. Бразайтис, Э. Гусейновене. Математическая модель для автоматического проектирования приводов с колебательными двигателями // Электроника и электротехника. – Каунас: Технология, 2006. – № 6(70). – С. 19–22.**

Рассматривается принцип создания универсальной математической модели для автоматизированного проектирования привода с двигателями колебательного движения. В случае рассматриваемых приводов с отдельным вариантом двигателя тому же самому объекту в каждом отдельном случае нужна индивидуальная математическая модель. Так появляются модели разных видов двигателей, которые, в зависимости от разных параметров, делятся на еще более широкий спектр математических моделей. Предложен принцип создания и применения универсальной математической модели для привода с двигателями колебательного движения. Ил. 2, библи. 5 (на английском языке; рефераты на английском, русском и литовском, яз.).

**A. Brazaitis, E. Guseinoviėnė. Švytuojamųjų pavarų automatizuotojo projektavimo matematinis modelis // Elektronika ir elektrotechnika. – Kaunas: Technologija, 2006. – Nr. 6(70). – P. 19-22.**

Apžvelgta pavarų su švytuojamaisiais varikliais universalus matematinio modelio sudarymo galimybė. Kiekvienu atskiru atveju analizuojant pavarą su skirtingu varikliu tam pačiam tyrimo objektui reikalingas individualus matematinis modelis. Keičiant variklio parametrus atsiranda dar didesnė aišė matematinių modelių. Pateikiamas pavarų su švytuojamaisiais varikliais universalus matematinio modelio sudarymo metodas bei jo taikymo ypatumai. Il. 2, bibl. 5 (anglų kalba; santraukos anglų, rusų ir lietuvių k.).

These parameters are the elements  $\mathbf{A}_{21}$  and  $\mathbf{R}_b$  of matrices (32) and (33). In particular case of drive there can be more changing parameters. To reduce extent of calculation it is needed to recalculate only these elements of matrix which depend on changing parameters.

Applying mathematical model for drives with reactive motor the equation of equivalent voltages of non-linear elements is not solved, therefore it is required to begin calculation from mode equation. In case of drives with pulsating current motors function of non-linear component is concretized with v-a characteristic of applied diode. Thus solution of mathematical model (19) in i-number of cycle of calculation process begins from solution of non-linear equation system taking out the value  $\mathbf{x}(i-1)$  of mode vector which is obtained from previous cycle.

### References

1. **Kudarauskas S.** Oscillating electrical machines // Klaipėda, 2004. 183 p.
2. **Brazaitis A., Guseinoviėnė E.** Reaktyviųjų švytuojamųjų variklių skaitinis valdymas // Technologijos mokslo darbai Vakarų Lietuvoje IV. – Klaipėda, 2004. – P. 183.
3. **Di Barba P., Savini A., Wiak S.** 2D/3D computer-aided analysis of electrostatic micromotors // Proc. ICEM'94. – Paris, 1994.
4. **Arpino F., Di Barba P., Navarra P., Savini A.** 3D global optimum of an electromechanical device // Proc. COMPUMAG, Miami, Ottobre/Novembre 1993. – IEEE Trans. on Magnetics, 1994. – Vol. 30, No. 5. – P. 3430.
5. **Di Barba P., Savini A.** Global optimization methodologies and application in electromechanics // Int. Journal of Applied Electromagnetics in Materials. – 1993. – Vol. 4, – No.2.– P. 98.

Submitted 2006 03 02

