

Forces of Shift of the Electromagnetic Motor

E. Matkevičius, L. Radzevičius

*Department of Automation, Vilnius Gediminas Technical University,
Naugarduko str. 41, LT-03227 Vilnius, Lithuania, phone: +370 5 2745063,
e-mails: edvardas.matkevicius@el.vtu.lt, lionginas.radzevicius@el.vtu.lt*

Introduction

Constant improvement of technological processes enables the perfection of the devices which actualize linear motions that appear so often. One of the possible ways of producing linear movements is linear electromagnetic motor (LEM). This type of motor possesses simple structure and signifies it self by many positive characteristics. The structure of LEM is submitted in Fig. 1 [1,2].

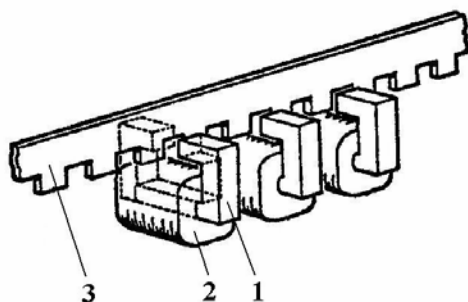

Fig. 1. Linear electromagnetic motor structure: 1 – electromagnetic core; 2 – excitation coil; 3 – saw-edged ferromagnetic rail

LEM is comprised of the original part in which there is situated C type magnetic core 1, with an air gap. On the magnetic core there has been wound the excitation coil 2 powered from the constant voltage resource. The secondary part (secondary element) is comprised of ferromagnetic saw-edged rail 3, the teeth of which get on the magnetic air gap between the poles of constant magnetic field. The thread of the teeth and magnetic core poles is not the same. LEM operation is based on the principle of induction. By connecting voltage in sequence to the electromagnetic coils the system of electromagnets (in case when the saw-edge rail is attached) or saw-edge rail (in case when the system of electromagnets is attached) starts moving similarly the same as the step-by-step motor with reactive rotor.

The main positive characteristics of LEM are the following:

- simple structure and technology of manufacturing;

- low probability of failure caused by simple structure and concentrated excitation coil;
- low power losses in the secondary element, they do not exceed low steel losses;
- low starting current, it doesn't exceed the double nominal current of the motor;
- it is possible to operate in the synchronic, asynchronous and discrete (step-by-step) operating mode;
- it is specified by simple launching, reverse and stopping;
- functional force of attraction per unit of the pole area is nearly ten times higher than in ordinary linear asynchronous motors.

The promising fields of LEM application are the sorting out of catalogued objects (books, medications, documents, spare parts, radio technical parts and etc.), storage, placement and delivery in accordance with the instructions, guarantee of the movements of robots and manipulators, automatic control of movements of some parts of machine-tools and conveyors. LEM may also be applied in the transportation mechanisms possessing air bags, in mechanized tools (vibrators, mechanical sledge hammers and etc.) [3-6].

High technical and economical indexes of LEM prove, that this type of motor is a promising one but for their successful implementation it is necessary to carry out comprehensive theoretical and experimental investigations [7-9].

The purpose of the article is to investigate theoretically LEM shift forces and derive their analytic expressions.

Forces developed by the motor

Ferromagnetic secondary element (the tooth of the rail), situated in the air gap between the poles of the excited electromagnet is under the shift force which has got three components in general. The size and direction of the components compiling general shift force depend not only on the m.m.f. of electromagnet, but depend on the structural parameters of the motor and mutual position of

the initial and secondary parts. Forces acting on the LEM are exhibited in Fig. 2.

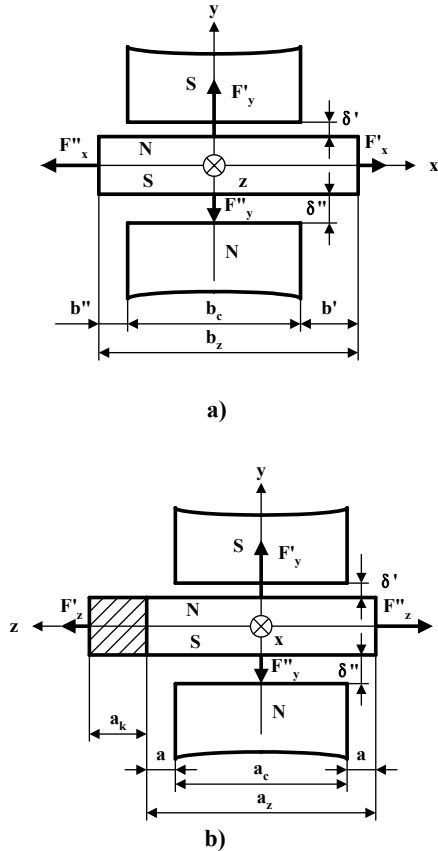

Fig. 2. Forces developed inside the LEM: a) – on the xy coordinates; b) – on the yz coordinates

When the tooth of the secondary element in the air gap in respect to the beginning of coordinates is shifted symmetrically then the components of the forces F'_x , F''_x , F'_y , F''_y , F'_z , F''_z are equal and induction forces do not operate towards the directions of the coordinates x, y, z.

After the induction appears towards the positive direction of coordinate x when $b' > b''$ (see Fig. 2, a)), the components F'_x , F''_x tend to be uneven because the symmetry of the lines of magnetic field forces fail. There appears negative induction force towards the direction of the x axis, which tries to return to the initial and secondary parts of the LEM into the initial position, then starts operating longitudinal attraction force of the motor. This force could be considered as a useful one, because it carries out shift in the linear direction and may carry out functional work.

In case when air gap is asymmetric longitudinally to the axis y, when $\delta' < \delta''$ (see Fig. 2, a)) the balance of the components of forces F'_y , F''_y is in trouble and there appears a transverse force of attraction. This force loads structural elements of LEM, causes additional mechanical losses and it is considered useless. That is why the structure of LEM has to be such for the air gap between the poles of electromagnet to be not only as possible narrower,

but symmetrical as well ($\delta' = \delta''$). Determining transverse attraction force is especially important in designing the motor, in calculating mechanical elements of LEM structure.

When LEM secondary element is saw-edged ferromagnetic rail, so due to this type of structure the magnetic structure of the motor is asymmetric longitudinally towards the axis z (see Fig. 2 teeth, that is why components of forces F'_z , F''_z do not remain all the time equal and there appears shift forces which could cause the vibrations of the motor. It is possible to avoid this hazardous factor by increasing the projection of the teeth of the secondary element behind the pole or in producing the teeth from a ferromagnetic material but remaining the structure connecting the teeth as non-ferromagnetic.

The analysis of determining shift forces has a significant effect in designing, constructing and implementing LEM.

Idealized linear electromagnetic motor model

In Fig. 3 there is presented an idealized model of linear electromagnetic motor.

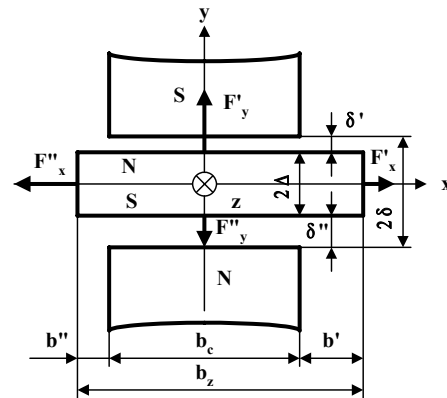

Fig. 3. Idealized linear electromagnetic motor model

In evaluating specific characteristics of LEM, for finding the solution of an idealized model there is selected the method of conformic images [10]. When calculating the electromagnetic field this method allows us to evaluate significantly complicated margins than it is done by applying other methods especially when the margins are rectangular. Besides that the solutions of this method are mostly simple and allow us to derive the analytic expressions of magnetic field density and magnetic conductance easy enough. The main restrictions of this method are such that in majority of problems the margins of the field have to be accepted as possessing infinite magnetic permeability or coinciding with the lines of magnetic flux. In compiling the magnetic field of rectangular shape for clearly expressed pole by means of conformic images there appear certain difficulties; that is why it is possible to accept certain assumptions which could simplify the solution of the problem. These assumptions alienate an idealized LEM model from the realistic LEM.

or

$$F_y = \frac{1}{2} \left[\varphi_v \cdot \left(\frac{d\Psi'_v}{d\delta'} - \frac{d\Psi''_v}{d\delta''} \right) + \varphi_a \cdot \left(\frac{d\Psi'_a}{d\delta'} - \frac{d\Psi''_a}{d\delta''} \right) \right], \quad (8)$$

where Ψ'_v , Ψ''_v – are components of the complete magnetic flux intersecting the plane z surface margins between the points $-\frac{b_c}{2} + j\delta'$ and $j\delta'$ corresponding to the tooth projections b' and b'' .

To determine shift forces there has been used surface integrating method when the surface margin (see Fig. 4) of idealized LEM model (see Fig. 3) located on the plane z is transformed into the real axis on the plane t (see Fig. 5) by selecting corresponding pairs of points on these planes in accordance with the Table 1.

Table 1. Appropriate coordinates on the planes z and t

Coordinates on the plane z	$j\infty$	$j\delta$	$-\infty$	b'	$b'' - j\infty$
Coordinates on the plane t	$-\infty$	-1	0	a	∞

The peak angles of the pole and the tooth are equal (are equal to $\frac{3\pi}{2}$), the Schwarz -Christopher [10] equation correlating z and t planes is

$$\frac{dz}{dt} = C \cdot \frac{\sqrt{(t+1)(t-a)}}{t}. \quad (9)$$

Function $z = f(t)$ is derived by integrating expression (9)

$$z = C \left[(t+a) \sqrt{\frac{t+1}{t-a}} + (1-a) \operatorname{arcth} \sqrt{\frac{t+1}{t-a}} + j\sqrt{a} \ln \left(\frac{2a+t(a-1)}{t(a+1)} - j \frac{2}{t} \sqrt{\frac{a(t+1)(t-a)}{a+1}} \right) \right] + K. \quad (10)$$

Integration constants C , K determine the configuration as polygon of the marginal surface and the ratio of scales between the planes z and t . By applying the method of subtraction at the point $t = 0$ we derive

$$C = -\frac{j\delta'}{\pi\sqrt{a}}. \quad (11)$$

Inserting C following (11) as well as adding together the coordinates of point pairs $z = j\delta'$, and $z = b'$, $t = a$ we derive:

$$K = 0, \quad a = 1 + p^2 \pm \sqrt{(1 + p^2)^2 - 1},$$

$$p = 2 \left(\frac{b'}{\delta'} \right)^2. \quad (12)$$

When the difference of magnetic potentials between the analyzed elements on the plane z is φ , then the solution on the plane t is :

$$w = \frac{\varphi}{\pi} \ln t. \quad (13)$$

Following the idealized LEM model the permeability of marginal surfaces is infinite that is why magnetic field strength in steel is equal to zero i.e. all the magnetic field energy is concentrated in the air gap. In this case the shift forces are calculated according to the expression:

$$F = \frac{1}{2} \mu_0 \int H^2 dz, \quad (14)$$

where H – is magnetic field strength on the surface $z = jq$.

After having evaluated the proper integration margins, shift forces are calculated following the expressions:

$$F'_{xv} = \frac{1}{2} \mu_0 \int_{j\delta'}^{j\infty} H^2 dz; \quad (15)$$

$$F'_{yv} = \frac{1}{2} \mu_0 \int_{-\frac{b_c}{2} + j\delta'}^{-j\delta'} H^2 dz \quad (16)$$

or

$$F'_{xv} = \frac{1}{2} \mu_0 \int_{j\delta'}^{j\infty} \left(\frac{dw}{dz} \right)^2 dz = \frac{1}{2} \mu_0 \int_{j\delta'}^{j\infty} \left(\frac{dw}{dt} \right)^2 \left(\frac{dt}{dz} \right)^2 dz; \quad (17)$$

$$F'_{yv} = \frac{1}{2} \mu_0 \int_{-\frac{b_c}{2} + j\delta'}^{-j\delta'} \left(\frac{dw}{dz} \right)^2 dz = \frac{1}{2} \mu_0 \int_{-\frac{b_c}{2} + j\delta'}^{-j\delta'} \left(\frac{dw}{dt} \right)^2 \left(\frac{dt}{dz} \right)^2 dz. \quad (18)$$

After changing the variables of integration we derive:

$$F'_{xv} = \frac{1}{2} \mu_0 \int_{-1}^{\infty} \left(\frac{dw}{dt} \right)^2 \left| \frac{dt}{dz} \right| dt; \quad (19)$$

$$F'_{yv} = \frac{1}{2} \mu_0 \int_0^{-1} \left(\frac{dw}{dt} \right)^2 \left| \frac{dt}{dz} \right| dt. \quad (20)$$

According to the expression (13) it is possible to get

$$\frac{dw}{dt} = \frac{\varphi}{\pi} \cdot \frac{1}{t}. \quad (21)$$

After inserting $\frac{dw}{dt}$ following (21) and $\frac{dt}{dz}$ following (9) into (19), (20) we derive:

$$F'_{xv} = \frac{\mu_0 \varphi_v \sqrt{a}}{2\pi \delta'} \int_{-1}^{-\infty} \frac{dt}{t \sqrt{(t+1)(t-a)}}; \quad (22)$$

$$F'_{yv} = \frac{\mu_0 \varphi_v \sqrt{a}}{2\pi \delta'} \int_{\delta'+1}^{-1} \frac{dt}{t \sqrt{(t+1)(t-a)}}. \quad (23)$$

After having completed the integration of the expressions (22), (23), it is derived:

$$F'_{xv} = \frac{\mu_0 \varphi_v^2}{2\pi \delta'} \left(\arcsin \frac{1-a}{1+a} - \frac{\pi}{2} \right); \quad (24)$$

$$F'_{yv} = \frac{\mu_0 \varphi_v^2}{2\pi \delta'} \left(\frac{\pi}{2} - \arcsin \frac{(\delta'+1)(1-a) - 2a}{(\delta'+1)(1+a)} \right). \quad (25)$$

The same way is used to determine the components of forces $F'_{xa}, F'_{ya}, F''_{xv}, F''_{yv}, F''_{xa}, F''_{ya}$ and then inserting them into (5), (7), there are derived analytic expressions of complete shift forces F_x, F_y :

$$F_x = \frac{\mu_0 a_c}{2\pi} \left[\frac{\varphi_v^2}{\delta'} \left(\arcsin \frac{1-a'_v}{1+a'_v} - \arcsin \frac{1-a''_v}{1+a''_v} \right) \right] + \frac{\mu_0 a_c}{2\pi} \left[\frac{\varphi_a^2}{\delta''} \left(\arcsin \frac{1-a'_a}{1+a'_a} - \arcsin \frac{1-a''_a}{1+a''_a} \right) \right]; \quad (26)$$

$$F_y = \frac{\mu_0 a_c}{2\pi} \cdot \frac{\varphi_v^2}{\delta'} \left[\pi - \arcsin \frac{\left(\frac{b_c}{2} + 1 \right) (1-a'_v) - 2a'_v}{\left(\frac{b_c}{2} + 1 \right) (1+a'_v)} \right] - \frac{\mu_0 a_c}{2\pi} \cdot \frac{\varphi_v^2}{\delta'} \left[\arcsin \frac{\left(\frac{b_c}{2} + 1 \right) (1-a''_v) - 2a''_v}{\left(\frac{b_c}{2} + 1 \right) (1+a''_v)} \right] +$$

$$+ \frac{\mu_0 a_c}{2\pi} \cdot \frac{\varphi_a^2}{\delta''} \left[\pi - \arcsin \frac{\left(\frac{b_c}{2} + 1 \right) (1-a'_a) - 2a'_a}{\left(\frac{b_c}{2} + 1 \right) (1+a'_a)} \right] - \frac{\mu_0 a_c}{2\pi} \cdot \frac{\varphi_a^2}{\delta''} \left[\arcsin \frac{\left(\frac{b_c}{2} + 1 \right) (1-a''_a) - 2a''_a}{\left(\frac{b_c}{2} + 1 \right) (1+a''_a)} \right]; \quad (27)$$

$$a'_v = 1 + (p'_v)^2 \pm \sqrt{\left[1 + (p'_v)^2 \right]^2 - 1}; \quad (28)$$

$$a''_v = 1 + (p''_v)^2 \pm \sqrt{\left[1 + (p''_v)^2 \right]^2 - 1}; \quad (29)$$

$$a'_a = 1 + (p'_a)^2 \pm \sqrt{\left[1 + (p'_a)^2 \right]^2 - 1}; \quad (30)$$

$$a''_a = 1 + (p''_a)^2 \pm \sqrt{\left[1 + (p''_a)^2 \right]^2 - 1}; \quad (31)$$

$$p'_v = 2 \left(\frac{b'_v}{\delta'} \right)^2, \quad p''_v = 2 \left(\frac{b''_v}{\delta'} \right)^2; \quad (32)$$

$$p'_a = 2 \left(\frac{b'_a}{\delta''} \right)^2, \quad p''_a = 2 \left(\frac{b''_a}{\delta''} \right)^2. \quad (33)$$

Conclusions

1. There have been analyzed shift forces operating in the linear electromagnetic motor and it was disclosed that in a general case components of three forces are operating there, and one force from them is the one that is functioning longitudinally to the horizontal axis is considered to be useful force of attraction and there has been evaluated the influence of components of separate forces.
2. There has been worked out an idealized linear electromagnetic motor model meant for determining analytically the shift forces by means of conformic images.
3. The idealized LEM model has been analytically investigated by means of conformic images and analytic expressions of shift forces operating on the horizontal and vertical axis depending on the geometric parameters of the motor were derived.
4. Analytic functional reliance of shift forces on the geometric parameters of the motor may be used in designing this type of linear electromagnetic motors, with further investigation of their characteristics.

References

1. **Bartholon M., Martin A., Moiroux A., Watson P., Lane F.** Electromagnetic motion imparting means and transportor system embodying the same. – United States patent 3.707.924. – 1973.
2. **Severinov V., Migalkin K., Nikulin N., Komarov V.** Device for step linear shift (in Russian). – Russian patent М. Кл.3 В 65 G25/00. – 1981.
3. New form of linear motor by – passes induction principle // Electrical Export Review. – 1973. – P. 82-85.
4. **Afonin A., Bilozor P., Grebenikov V. Dichnenko J., Melnicuk L.** Electromagnetic drive for robotic and technical system (in Russian) / Ин-т электродинамики академии наук Украины. – Киев: Наукова думка, 1986. – 272 с.
5. **Spicer – Couture M. A.** New generation linear electromagnetic motores with high positioning (in French) // Elemente prod. – serv. 1973. – P. 41–47.
6. **Afonin A., Grebenikov V.** Linear electromagnetic drive. Calculation of static and dynamic characteristic (in Russian). – Киев: Ин-т электродинамики Академии наук Украины, 1981. – 53 с.
7. **Bessonov L. A.** Fundamental theoretic of electrical engineering. Electrical circuit. (in Russian). – М.: Гардарики, 2002. – 638 с.
8. **Edler J., Föhse M., Stöltling H.-D., Gatzel H.H.** Electromagnetic microlinear motor (in German) // Proceedings of actuator. – 2001. – P. 117–121.
9. **Edler J. Föhse M., Stöltling H.-D., Gatzel H.H.** A Linear Microactuator with Enhanced // Design Micro System Technologies. – Springer Verlag, 2002. – Vol. 7. – P. 261–264.
10. **Gatzel H.H., Zeadan J., Karyazin A.** High Precision Machining of a Longitudinal Bearing for a Linear Microactuator // 3rd Int. Euspen Conf. – 2002. – P. 325–328.

Submitted 2006 02 18

E. Matkevičius, L. Radzevičius. Forces of Shift of the Electromagnetic Motor // Electronics and Electrical Engineering. – Kaunas: Technologija, 2006. – No. 6(70). – P. 5–10.

There have been analyzed shift forces operating in the linear electromagnetic motor and it was disclosed that in a general case there are operating the components of three forces, and one force from them is the one that is functioning longitudinally to the horizontal axis and is considered to be useful force of attraction and there has been evaluated the influence of components of separate forces. There has been worked out an idealized linear electromagnetic motor model meant for determining analytically the shift forces by means of conformic images. Idealized LEM model has been analytically investigated by means of conformic images and analytic expressions of shift forces operating on the horizontal and vertical axis depending on the geometric parameters of the motor were derived. Analytic functional reliance of shift forces on the geometric parameters of the motor may be used in designing this type of linear electromagnetic motors, with further investigation of their characteristics. Il.5, bibl. 10 (in English; summaries in English, Russian and Lithuanian).

Л. Радзевичюс, Э. Маткявичюс. Силы смещения линейного электромагнитного двигателя // Электроника и электротехника. – Каунас: Технология, 2006. – № 6(70). – С. 5–10.

Произведен анализ сил смещения, действующих в линейном электромагнитном двигателе, показано, что в общем случае действуют три составляющие, из которых сила по горизонтальной оси считается полезной силой тяги и сделана оценка действия отдельных составляющих. Составлена идеализированная модель линейного электромагнитного двигателя, предназначена для аналитического определения сил смещения методом конформных отображений. Методом конформных отображений аналитически исследована идеализированная модель линейного электромагнитного двигателя и получены аналитические выражения сил смещения по горизонтальной и вертикальной осям в зависимости от геометрических параметров электромагнитного двигателя. Аналитические функциональные зависимости сил смещения от геометрических параметров двигателя могут быть использованы при проектировании электромагнитных двигателей этого типа, для дальнейшего исследования их свойств. Ил. 5, библи. 10 (на английском языке; рефераты на английском, русском и литовском яз.).

E. Matkevičius, L. Radzevičius. Tiesiaieigio elektromagnetinio variklio postūmio jėgos // Elektronika ir elektrotechnika. – Kaunas: Technologija, 2006. – Nr. 6(70). – P. 5–10.

Išanalizuotos postūmio jėgos, veikiančios tiesiaieigiame elektromagnetiniame variklyje, parodyta, kad bendroju atveju veikia trys jėgų dedamosios, iš kurių jėga, veikianti išilgai horizontaliosios ašies, laikoma naudingąja traukos jėga, ir įvertintas atskirų jėgų dedamųjų poveikis. Sudarytas idealizuotas tiesiaieigio elektromagnetinio variklio modelis, skirtas postūmio jėgoms analiziškai nustatyti konforminių atvaizdų metodu. Konforminių atvaizdų metodu analiziškai ištirtas idealizuotas tiesiaieigio elektromagnetinio variklio modelis ir gautos analizinės postūmio jėgų horizontaliąja ir vertikaliąja ašimis išraiškos, priklausančios nuo variklio geometrinų parametrų. Analizinė funkcinė postūmio jėgų priklausomybė nuo variklio geometrinų parametrų gali būti naudojama projektuojant šio tipo tiesiaieigius elektromagnetinius variklius, toliau tiriant jų savybes. Il.5, bibl. 10 (anglų kalba; santraukos anglų, rusų ir lietuvių k.).

DOI: 10.5755/j02.eie.10683