

Methods and Algorithms for Control of Mobile Robots Based on Multi-agents Technology

M. Ketlėrius, V. Mačerauskas

Department of Control Technology, Kaunas University of Technology,

Studentų str. 48, LT-51367 Kaunas, Lithuania; phone: +370 37 300290; e-mail: mindaugas@accel.lt

Introduction

Mobile robots as universal technical system are one of most interesting aims of the scientific researches in the field of robotics. The reason of this interest is absolutely clear – there are a lot of areas they can be used: industry, medicine, education, cosmic researches and other.

There is increasing the interest in multi robot systems at the moment, because the same tasks or missions can be performed faster having the collective of intelligent robots. The same task can be divided in to some subtasks and performed by several robots having different capabilities. In this case we solve the same problem easier and probably cheaper changing the single high sophisticated robot system by several independent systems of limited, but probably different capabilities.

Specifically, coordination and interaction of multiple robots is generally denoted by the term collective behaviour, which has been studied in the field of Multi-agent systems (MAS) involving multiple intelligent software agents. A wide range of issues such as task decomposition, task allocation, fault-tolerance, correctness, or others related to quantified measures of cooperation have been trying to solve by use of multi-agent systems [1].

However on purpose to perform the tasks with this complex system it is necessary to have intelligent control structure (ICS) controlling the overall system components.

We will present the main concepts of MAS technology and will introduce to implemented intelligent robot control architecture KAMARA based on multi-agents technology in this article.

Multi-agent systems

Agent definition: a software entity which functions continuously and autonomously in a particular environment, often inhabited by other agents and processes [2].

Agent is described as the software component exhibiting the following characteristics:

1. **Autonomy.** An agent has its own internal thread of execution, typically oriented to the achievement of a specific task, and it decides for itself what actions it should perform at what time.
2. **Situatedness.** Agents perform their actions while situated in a particular environment. The environment may be a computational one (e.g., a Web site) or a physical one (e.g., a manufacturing pipeline), and an agent can sense and effect some portions it.
3. **Proactivity.** In order to accomplish its design objectives in a dynamic and unpredictable environment the agent may need to act to ensure that its set goals are achieved and that new goals are opportunistically pursued whenever appropriate.

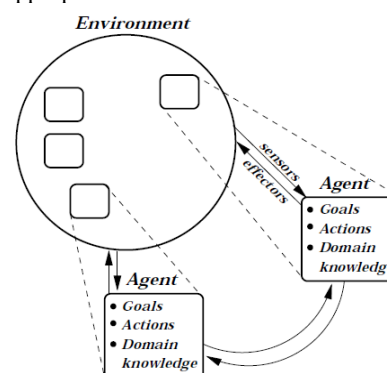

Fig. 1. Classical multi-agent behaviour scheme

Agents can be useful as stand-alone entities that are delegated for particular tasks. However, in the majority of cases, agents exist in environments that contain other agents. In these multi-agent systems, the global behaviour derives from the interaction among the constituent agents. Agents interact (cooperate, coordinate or negotiate) with one another, either to achieve a common objective or because this is necessary for them to achieve their own objectives [3].

Multi-agent systems (MAS) are based on the idea that a cooperative working environment comprising synergistic software components can cope with problems which are

hard to solve using the traditional centralized approach to computation. Smaller software entities – software agents – with special capabilities (autonomous, reactive, pro-active and social) are used instead to interact in a flexible and dynamic way to solve problems more efficiently.

Agents model each other’s goals and actions; they may also interact directly (communicate) [4].

The classical multi-agents behaviour scheme is presented in Fig 1.

Intelligent Control Architectures for Multi-Agent Systems

In principle, complex systems, which consist of several executive subsystems (agents), can be divided into three different design classes:

- ✓ Centralized System. A decision is made in a central mechanism and transmitted to executive components (see Fig. 2a).
- ✓ Distributed Systems. The decision is made by a negotiation process among the executive components and executed by them (see Figure 2b).
- ✓ Decentralized Systems. Each executive component makes its own decisions and executes only these decisions (see Fig. 2c).

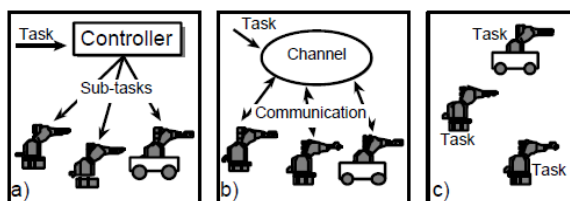

Fig. 2. Execution view of multi-agent systems

From the definition of an agent, it is possible to describe and explain hierarchical systems (see Fig. 3). An agent consists of three parts: communicator, head (for planning and action selection), and body (for action execution).

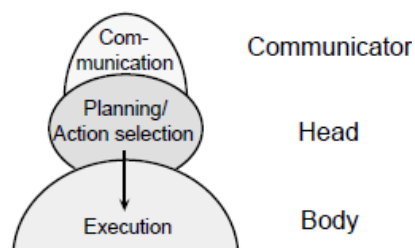

Fig. 3. Elements of an agent

The communicator connects the head to other agents on the same communication level or higher. The head is responsible for the action selection process for the body (centralized approach), organizes the communication among the bodies agents actively or passively (distributed approach), or is only a frame to find a principle of order for the decentralized approach. The body itself consists of one or more executive components, which can be similarly considered as agents.

The executive components can be divided into three classes, as well as the components of the process for planning and action selection, i.e., the head of an agent (see Fig. 4).

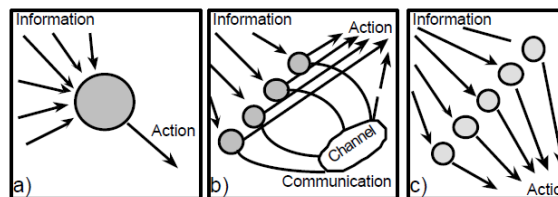

Fig. 4. Three ways to make decisions, plan or select actions

The classification is as follows:

- ✓ Centralized action selection. Available information is centrally processed by a decision making component and transformed into an action for the agent's body (linear planner).
- ✓ Distributed action selection. Available information is processed by several decision making components, which communicate and negotiate to come to a decision.
- ✓ Decentralized action selection. The available information is processed independently by several decision making components and transformed locally in their own action decision for the agent's body.

Multi-agent Robot Control Architecture KAMARA

In the following sections will be presented the distributed control architecture KAMARA (Karlsruhe Multi Agent Robot Architecture) developed at University of Karlsruhe. KAMARA is intelligent control architecture for distributed task execution actually implemented in the Karlsruhe Autonomous Assembly Robot KAMRO.

The KAMRO robot system consists of several subcomponents like two manipulators, hand-eye cameras, one overhead-camera and a mobile platform. These agents have to communicate and negotiate with each other to collect the missing information and to perform the desired task.

Agent Model

An agent A consists of a communicator, a head, and a body. In KAMARA system, an agent, like a manipulator, is only capable of performing one task at a time, because its body is implemented as a single procedure. The head with a communicator not only has to control the body, but also has to communicate and negotiate with other agents or heads. An important reason for communication is the determination of the agent for executing an elementary operation. This means the head (and the communicator) has to deal with several different tasks at one time [5].

Therefore, a head and a communicator are implemented as a variable sets H and C of equal independent processes H and C for planning, communication, and negotiation (see Fig. 5). An agent A can be described as:

$$A = (C, H, B), \quad (1)$$

where C – a set of communicators, H – a set of heads, B – is an agent's body.

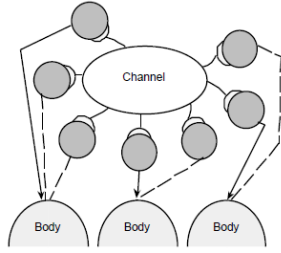

Fig. 5. Agents with several heads and communicators

Communication Mechanism

The communication mechanism for all agents and for task distribution or task allocation is Blackboard-like. This mechanism holds all executable missions m in a mission set:

$$M = \{m_1, m_2, \dots, m_m\}. \quad (2)$$

M gets new missions M_{n+1} from the cell planner P or from the agents of KAMRO:

$$P, A: M = M \cup M_{n+1}. \quad (3)$$

This multi-agent architecture also can be useful on the cell level. In this case the communication mechanism of one KAMRO robot is the head of a KAMRO-Agent (distributed action selection architecture), and it is possible to use more than one KAMRO robot for complex tasks like carrying a large object with several robots or loaning one manipulator to a second robot (see Fig. 6).

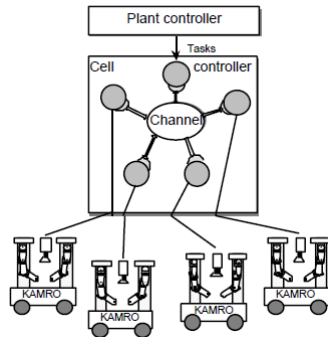

Fig. 6. Distributed cell controller view

The communication form between the system agents is asynchronous. Asynchronous communication is a good solution for independent task execution, but not always this communication mechanism can guarantee real-time constraints. For example, there may be the situation where two manipulators grasp a large or heavy part, and by this way close a cinematic chain. In this case, there is a need to have different control concept.

To guaranty the real-time constrains, in KAMARA architecture is realized the possibility to change the communication mechanism from asynchronous to

synchronous between agents and change the planning mechanism. Synchronous communication mechanism is implemented through the special executive agents. These special agents SA have, like all other agents, a head H and a communicator C . The body is allowed to allocate bodies of other agents, if available, and control them by special communication channels with high transfer rates (see Fig. 7). During this time, the normal agents have no access to their bodies, since they are used by the special agent.

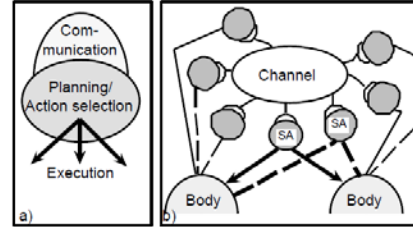

Fig. 7. Centralized planning using special agents

If the information exchange between agents of the same team increases so dramatically that this results in a narrowing in the communication channels, then these agents have the possibilities to refer to a closer internal relationship.

Task Negotiation in KAMARA

If a new mission is assigned from the mission set M , it is possible that many agents are able to work on that task. This problem in KAMARA architecture is solved performing negotiation process between agents. Negotiation process depending on the situation can be performed by:

- ✓ a centralized mediator;
- ✓ a selected candidate;
- ✓ all (or many) candidates.

In case of centralized mediator, similar to human behaviour, a selected candidate is considered. In this concept, the mediating agent demands a mission-solving evaluation from all other competing candidates compares these offers and chooses the best one.

A mission in this architecture is represented as:

$$m = (n, I, R, P, t, A, V, E), \quad (4)$$

where n – mission identification number, I – a list of mission initiators, R – a set of receivers, interested in mission solution, P – solution presence indication signal, t – task, A – list of competing agents, V – valuations of agents, E – is an execution set.

The negotiation procedure starts when a new mission appears in the mission set. The communicator of every agent, whether the body of this agent is already performing another mission or not, searches for tasks that it can solve in the mission set. One of these competing agents should negotiate with the rest of them. If the candidate list A is empty, the first competing agent head acts as mediator and stores its identification number into the first position of the field A . When another agent becomes interested in mission solving, it is obvious that this agent head should evaluate its problem solving ability and send it to the mediator by

writing the information into the corresponding position of the valuation field V . The mediator calculates its own ability to work on the mission and waits an a priori defined time t for the evaluation of all other agents a_2, a_3, \dots, a_n , compares these evaluations and chooses the best agent a_i of the entire candidate list $A=(a_1, a_2, \dots, a_n)$ to work on the mission.

This way, the candidates that are not able to calculate their evaluation fast enough or are disabled are not involved in the negotiation process. Because all agents that have the ability to work on the mission are integrated in this selection procedure, it can be that an agent which was previously working on a different task can enter the competing process later when its body is "free".

Conclusions

Main features of multi-agent concept and the agent based control architecture KAMARA for mobile robots has been presented in this article.

Developing control systems for collectives of mobile robots raises the need to solve cooperation problems.

Some type of cooperation problems actual for mobile robotics such as task decomposition, task allocation, fault-tolerance or others can be solved using the multi-agent approach.

Intelligent control architecture KAMARA based on multi-agents technology uses the advantages of distributed control (modularity, fault tolerance, extensibility).

References

1. **Cao Y. U., Fukunaga A. S., Kahng A. B.** Cooperative Mobile Robotics: Antecedents and Directions // Autonomous Robots. – Kluwer Academic Publishers, 1997. – P. 1–23.
2. **Bradshaw J. M.** Software Agents // Available on the Web: <http://pan.nuigalway.ie/code/docs/agents.pdf>.
3. **Zambonelli F., Jennings N. R., Wooldridge M.** Developing Multiagent Systems: The Gaia Methodology // ACM transactions on Software Engineering and Methodology. – 2003. – Vol. 12 – P. 320.
4. **Stone P., Veloso M.** Multiagent Systems: A Survey from a Machine Learning Perspective // Autonomous Robotics. – 2003. – Vol. 8, No. 3.
5. **Laengle T., Lueth T. C., Rembold U., Woern H.** A Distributed Control Architecture for Autonomous Mobile Robots – Implementation of the Karlsruhe Multi-Agent Robot Architecture (KAMARA) // Advanced Robotics. – 1998. – Vol. 12, No. 4 – P. 411–425.

Submitted for publication 2006 03 01

M. Ketlėrius, V. Mačerauskas. Methods and Algorithms for Control of Mobile Robots Based on Multi-agents Technology // Electronics and Electrical Engineering. – Kaunas: Technologija, 2006. – No. 5(69). – P. 25–28.

The need to solve more complex and flexible tasks in nowadays technical world increases the interest in multi robot systems. In this case tasks can be more complex than for single robot system. The system using several simple robots can be cheaper, easier, more flexible, and the better performance can be reached. Although there has been done a lot of effort in this field of robotics, currently there is a lack in the design methods of the intelligent control structure (ICS) for such complex systems.

There were presented the main concepts of Multi-agents (MAS) technology and implemented intelligent control architecture KAMARA for mobile robots based on multi-agents technology was introduced. III. 7, bibl. 5 (in English; summaries in English, Russian and Lithuanian).

M. Кэтлерюс, В. Мачераускас. Методы и алгоритмы для контроля мобильных роботов на основе технологии мультиагентов // Электроника и электротехника. – Каунас: Технологія, 2006. – № 5(69). – С. 25–28.

В настоящее время потребность решить более сложные и гибкие задачи в технике увеличивает интерес к системам с несколькими роботами. В этом случае задачи могут быть более сложными, чем для системы с одним роботом. Система, использующая несколько простых роботов, может быть более дешевой, простой, более гибкой и лучше работать. Хотя были сделаны большие усилия в этой области робототехники, в настоящее время нехватает методов проектирования интеллектуальной структуры контроля (ИСК) таких систем.

Представлены главные понятия технологий мультиагентов (MAS) и интеллектуальная архитектура контроля мобильных роботов KAMARA, создана на основе технологии мультиагентов. Ил. 7, библи. 5 (на английском языке; рефераты на английском, русском и литовском яз.).

M. Ketlėrius, V. Mačerauskas. Mobilijų robotų valdymo metodai ir algoritmai, pagrįsti multiagentų technologija // Elektronika ir elektrotechnika. – Kaunas: Technologija, 2006. – Nr. 5(69). – P. 25–28.

Šiandienos pasaulyje didėjantis poreikis spręsti vis sudėtingesnes užduotis kelia susidomėjimą robotų kolektyvų sistemomis. Šiuo atveju galima spręsti sudėtingesnes užduotis nei su vienu robotu. Sistema, naudojanti keletą paprastų robotų, gali būti pigesnė, paprastesnė, lankstesnė, be to, gali būti geresnės jos charakteristikos. Nors šiai robotų technikos sričiai skiriama daug dėmesio, kol kas trūksta intelektualų tokių sudėtingų sistemų valdymo struktūrų sudarymo metodų.

Nurodytos pagrindinės multiagentų technologijos ypatybės ir multiagentų technologija pagrįsta intelektualiai mobilijų robotų valdymo architektūra KAMARA. II. 7, bibl. 5 (anglų kalba; santraukos anglų, rusų ir lietuvių k.).

