

Critical Slip and Characteristics of Induction Motor for Borehole Investigating Devices

S. Gečys

Department of Electric Power Systems, Kaunas University of Technology,
Studentų str. 48, LT-51367 Kaunas, Lithuania; tel. + 370 37 300277, e-mail: steponas.gecys@ktu.lt

P. Smolskas

Department of Process Control, Kaunas University of Technology,
Studentų str. 50, LT-51368 Kaunas, Lithuania, e-mail: pranas.smolskas@ktu.lt

Introduction

The single-phase asynchronous capacitor motor with solid ferromagnetic rotor for the borehole investigating device drive is successfully used in the borehole of which medium temperature does not exceed $+200^{\circ}\text{C}$. [1, 2].

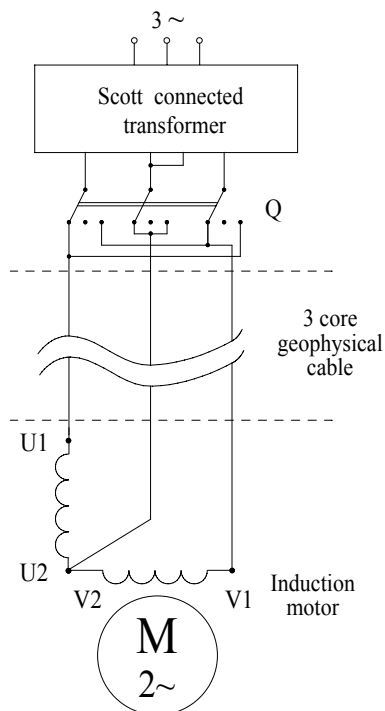

Fig. 1. Supply scheme of two-phase symmetric induction motor

For the boreholes of which medium temperature exceeds $+200^{\circ}\text{C}$ it is expedient to use two-phase or three-phase symmetric induction motors with solid ferromagnetic rotors. The special demands for these

motors obligate to design and investigate the characteristics.

In general the single-phase asynchronous capacitor motor for borehole investigating devices is made as symmetric two-phase motor with solid ferromagnetic rotor [2], but it is supplied from single-phase network.

The supply scheme of two-phase symmetric induction motor supplied through the long three-core geophysical cable is presented in Fig. 1. It is important to note that the thermal resistance capacitor for symmetric motor is not necessary. Commonly for the borehole investigation self-contained supply is used. The measuring of a borehole ground parameters and remote control needs less electric power than for the supply of motor and as a rule the power supply-source has limited power. The motor reversing is carried out with starting on-off switch Q (Fig. 1).

Critical Slip of Induction Motor taking into account Long Geophysical Cable and the Inner Complex Impedance of Power-supply Source

The case when conventional induction motor is supplied from the voltage source (i. e. when the inner complex impedance of the power-supply source is significantly smaller than the input impedance of motor and the supply complex voltage of motor is constant) is widely analyzed according to general theory of many researchers. The peculiarities and characteristics of an induction motor supplying from limited power-supply source can be changed essentially compared with the case when motor is supplying from unlimited voltage source.

As a rule the critical slip and maximum electromagnetic torque of the symmetric induction motor are determined taking into account L equivalent circuit parameters per phase. But this L equivalent circuit does not evaluate the distributed parameters of the long geophysical cable as well as the input impedance of the power-supply source and the known expression of critical slip of the

symmetric induction motor with solid ferromagnetic rotor [3] is unfit for use.

Let's change the geophysical cable to the four-pole switched on between the power-supply source and electric motor (Fig. 2).

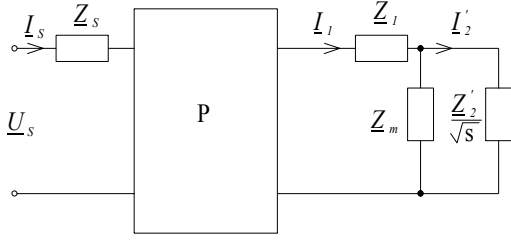

Fig. 2. Supply circuit of induction motor operating in the limited power system: \underline{U}_S is the complex voltage of power-supply source; \underline{I}_S is the input complex current; P is the four-pole; \underline{Z}_S is the inner complex impedance of the power-supply source; \underline{Z}_1 , \underline{Z}_M , \underline{Z}'_2 , is the L equivalent circuit complex parameters of induction motor; s is the slip; \underline{I}_1 , \underline{I}'_2 is the stator, equivalent rotor complex currents

We would try to deduce a formula of critical slip which evaluate the inner complex impedance of a power-supply source and distributed parameters of a long geophysical cable.

By applying the calculation rule of four-pole to supply circuit (Fig. 2), the complex of stator current can be expressed as follows

$$\underline{I}_1 = \frac{\underline{U}_S}{\underline{A}_{11}\underline{Z}_M + \underline{A}_{12} + \underline{A}_{21}\underline{Z}_M\underline{Z}_S + \underline{A}_{22}\underline{Z}_S}; \quad (1)$$

where

$$\underline{Z}_M = \underline{Z}_1 + \frac{\underline{Z}_m \underline{Z}'_2 / \sqrt{s}}{\underline{Z}_m + \underline{Z}'_2 / \sqrt{s}}; \quad \underline{A}_{11} = \underline{A}_{22} = \cosh \left[\underline{\gamma} \left(\ell_1 \frac{r_{0\Theta_0}}{r_{0\Theta_r}} + \ell_2 \right) \right];$$

$$\underline{A}_{12} = \underline{Z}_0 \sinh \left[\underline{\gamma} \left(\ell_1 \frac{r_{0\Theta_0}}{r_{0\Theta_r}} + \ell_2 \right) \right];$$

$$\underline{A}_{21} = \sinh \left[\underline{\gamma} \left(\ell_1 \frac{r_{0\Theta_0}}{r_{0\Theta_r}} + \ell_2 \right) \right] / \underline{Z}_0;$$

$$\underline{\gamma} = \sqrt{(r_{0\Theta_r} + j\omega_1 L_0)(g_{0\Theta_r} + j\omega_1 C_0)}; \quad \underline{Z}_0 = \sqrt{\frac{r_{0\Theta_r} + j\omega_1 L_0}{g_{0\Theta_r} + j\omega_1 C_0}};$$

$$r_{0\Theta_r} = \frac{r_{0\Theta_0} + r_{0\Theta_{\ell_2}}}{2}; \quad r_{0\Theta_0} = r_{0\Theta_{0K}}(1 + \alpha_T(\Theta_0 - \Theta_{0K}));$$

$$r_{0\Theta_{\ell_2}} = r_{0\Theta_0}(1 + \alpha_T(\Theta_{\ell_2} - \Theta_0)); \quad \omega_1 = 2\pi f_1;$$

$r_{0\Theta_r}$ is the average specific resistance; $r_{0\Theta_{0K}}$ is the specific resistance of the cable according to catalogue data at temperature Θ_{0K} ; Θ_0 is the temperature at the borehole surface; Θ_{ℓ_2} is the temperature in the borehole depth ℓ_2 ; α_T is the temperature coefficient of the conductor resistance; ℓ_1 is the cable length on the ground

surface; ℓ_2 is the let down in borehole cable length; $\ell = \ell_1 + \ell_2$.

The complex of equivalent rotor current (Fig. 2) is expressed as:

$$\underline{I}'_2 = \underline{I}_1 \frac{\underline{Z}_m}{\underline{Z}_m + \underline{Z}'_2 / \sqrt{s}}. \quad (2)$$

Then the electromagnetic power of motor can be written as:

$$P_{em} = m_1 \left(\underline{I}'_2 \right)^2 \frac{R'_2}{\sqrt{s}}; \quad (3)$$

where m_1 is the number of phase; R'_2 is the equivalent of rotor resistance.

Substituting the equation (2) into equation (3) and after the simple transformation electromagnetic power is expressed as:

$$P_{em} = \left| \frac{m_1 \underline{U}_S^2}{\left(\underline{A}_{11}(\underline{Z}_1 + \underline{Z}_S) + \underline{A}_{12} + \underline{A}_{21}\underline{Z}_1\underline{Z}_S \right) + \frac{\underline{Z}'_2}{\underline{Z}_m \sqrt{s}}} \times \frac{R'_2}{\left(\underline{A}_{11}(\underline{Z}_1 + \underline{Z}_m + \underline{Z}_S) + \underline{A}_{12} + \underline{A}_{21}(\underline{Z}_1\underline{Z}_S + \underline{Z}_m\underline{Z}_S) \right)^2 \sqrt{s}} \right|; \quad (4)$$

After differentiation of the electromagnetic power equation (4) according to slip

$$\frac{\partial P_{em}}{\partial s} = 0 \quad (5)$$

and further solving this equation, then the critical slip therefore is given as

$$s_c = \pm \left(\frac{\underline{Z}'_2 (\underline{A}_{11}(\underline{Z}_1 + \underline{Z}_m + \underline{Z}_S) + \underline{A}_{12})}{\underline{Z}_m (\underline{A}_{11}(\underline{Z}_1 + \underline{Z}_S) + \underline{A}_{12} + \underline{A}_{21}\underline{Z}_1\underline{Z}_S)} + \frac{\underline{A}_{21}(\underline{Z}_1\underline{Z}_S + \underline{Z}_m\underline{Z}_S)}{\underline{Z}_m (\underline{A}_{11}(\underline{Z}_1 + \underline{Z}_S) + \underline{A}_{12} + \underline{A}_{21}\underline{Z}_1\underline{Z}_S)} \right)^2 \sqrt{s}. \quad (6)$$

We aim to prove that the obtained critical slip formula equation (6) is the general case as it is known in scientific literature [3]. In this particular approach, if the motor is supplied from a high-capacity power-supply source and directly connected to power-supply source (i.e. $\underline{Z}_S = 0$, $\underline{A}_{11} = 1$, $\underline{A}_{12} = \underline{Z}_C = 0$, the insulation currents of the geophysical cable are denied) then the equation (6) can be written as:

$$s_c = \pm \left(\frac{\underline{Z}'_2 (\underline{Z}_1 + \underline{Z}_m)}{\underline{Z}_m \underline{Z}_1} \right)^2 = \pm \left(\frac{\underline{Z}'_2 C}{\underline{Z}_1} \right)^2 = \pm \frac{(\underline{Z}'_2)^2 C^2}{\underline{Z}_1^2}; \quad (7)$$

where

$$C = \sqrt{\frac{(R_1 + R_m)^2 + (X_1 + X_m)^2}{R_1^2 + R_m^2}}; \quad \underline{Z}_1 = \sqrt{R_1^2 + R_m^2}.$$

After the simple transformation equation (7) becomes as follows:

$$s_c = \pm \frac{(Z_2')^2 C^2}{Z_1^2} = \pm \left(\frac{CR_2'}{X_1} \right)^2 \cdot \frac{1+a^2}{1+b^2}; \quad (8)$$

where $a = \frac{X_2'}{R_2}$; $b = \frac{R_1}{X_1}$.

We showed that the formula of critical slip (8) absolutely coincides with data presented in [3]. It is important to underline that equation (6) is the general case of a critical slip formula of the magnetic rotor taking into account the inner complex impedance of power-supply source and the distributed parameters of long geophysical cable.

Characteristics of Motor and Discussion

Substituting the expression of critical slip s_c equation (6) in place s into equation (4) and after the simple transformation the maximum electromagnetic power is therefore given as:

$$P_{em,max} = \frac{m_1 U_S^2 Z_m}{4Z_2' (A_{11}(Z_1 + Z_S) + A_{12} + A_{21}Z_1 Z_S)} \times \frac{R_2'}{A_{11}(Z_1 + Z_m + Z_S) + A_{12} + A_{21}(Z_1 Z_S + Z_m Z_S)} \quad (9)$$

The electromagnetic torque of motor can be written as:

$$T_{em} = \frac{pP_{em}}{\omega_1}; \quad (10)$$

where p is the number of pole pairs.

The supply voltage of motor is not constant and changes in the slip range (0-1). Then it can be written as:

$$\underline{U}_M = \underline{I}_1 \cdot \underline{Z}_M \quad (11)$$

Table 1. The computed main parameters of the borehole motor at the different temperatures in borehole depths and supply voltages

Parameters	$\Theta_{\ell_2} = +22^\circ\text{C};$ $\ell_1 = 8,6 \text{ km};$ $\ell_2 = 0,1 \text{ km}$		$\Theta_{\ell_2} = +250^\circ\text{C};$ $\ell = \ell_2 = 8,7 \text{ km}$	
	$U_S = 280\text{V}$	$U_S = 220\text{V}$	$U_S = 280\text{V}$	$U_S = 220\text{V}$
s_c	3,75	3,75	4,50	4,50
$P_{em,max}, \text{W}$	107,9	66,60	65,67	40,54
$P_{em(s=1)}, \text{W}$	96,93	59,84	57,16	35,29
$T_{em(s=1)}, \text{N}\cdot\text{m}$	0,309	0,191	0,182	0,112
$U_{M(s=1)}, \text{V}$	195,6	153,7	187,9	147,6
$I_{1(s=1)}, \text{A}$	0,54	0,42	0,41	0,32
$I_{2(s=1)}, \text{A}$	0,35	0,28	0,22	0,17
$P_{s=0,3}, \text{W}$	74,19	45,8	42,79	26,42

The characteristics of the borehole motor can be effectively computed at any borehole dept if it is known such data: the temperature at the borehole surface; the

medium temperature at the borehole depth ℓ_2 ; the let down in borehole cable length ℓ_2 ; the length of cable ℓ and the parameters of cable.

The computed characteristics of symmetric two-phase induction motor with solid rotor (the parameters of equivalent circuit per phase at $+20^\circ\text{C}$ are: $Z_1 = 46 + j48 \Omega$; $Z_m = 0 + j612 \Omega$; $Z_2' = 390 + j234 \Omega$; and of the cable: $r_{0\Theta 0K} = 25,5 \Omega/\text{km}$; $C_0 = 0,2 \mu\text{F}/\text{km}$; $g_{0\Theta 0K} = 0 \text{ S}/\text{km}$; $L_0 = 0 \mu\text{H}/\text{km}$) are presented in table 1 and Figs. 3 and 4. The comparison between the cases when motor operates at borehole depth $\ell = \ell_2 = 8,7 \text{ km}$ ($\Theta_{\ell_2} = +250^\circ\text{C}$) and $\ell_2 = 0,1 \text{ km}$ ($\ell_1 = 8,6 \text{ km}$; $\Theta_{\ell_2} = +22^\circ\text{C}$) it electromagnetic torque $T_{em(s=1)}$ as well as and power $P_{em(s=1)}$ differs approximately 1,7 times (table 1).

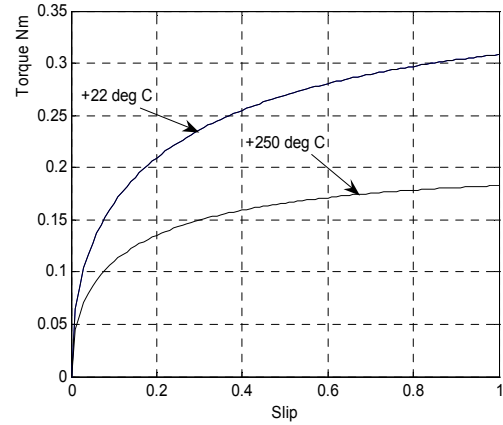

Fig. 3. Torque-slip characteristics of the motor at $U_S = 280 \text{ V}$

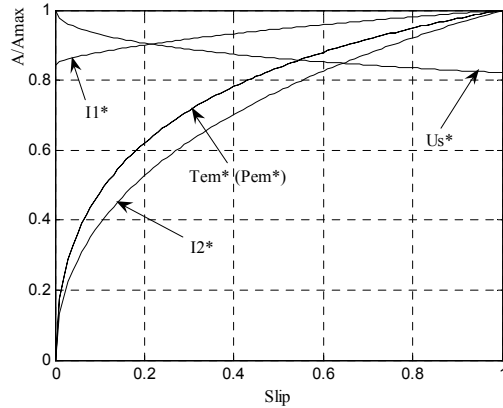

Fig. 4. Related torque (power), currents and voltage as function of the slip at $\Theta_{\ell_2} = +250^\circ\text{C}$, $\ell_2 = 8,7 \text{ km}$, $U_S = 280 \text{ V}$ (relative quantity A/A_{max} is the part of maximal value A_{max})

The borehole motor load torque is not constant due to operating cycle [4], then the motor working point changes and therefore the characteristics of motor which depended on slip are as the main.

It is expedient to decrease the supply-source voltage till 220V, because the main characteristics of motor are just the same as it operates at the big depth when motor operates at small depths.

There is a possibility to control the voltage of power-source taking into account the value of the geophysical

cable active resistance $R_{C\Theta} = r_{0\Theta v} \left(\ell_1 \frac{r_{0\Theta 0}}{r_{0\Theta v}} + \ell_2 \right)$, which is

proportional to the borehole depth and borehole medium temperature.

Conclusions

For the boreholes of which medium temperature exceeds + 200°C it is expedient to use two-phase induction motor with solid ferromagnetic rotor.

The critical slip and the maximum electromagnetic power expressions of the symmetric induction motor with solid rotor taking into account the inner complex impedance of the power-supply source and the distributed parameters of the long geophysical cable have been derived. It has been proved that derived critical slip expression is the general case of a critical slip formula.

The algorithm for the study of the motor characteristics taking into account the parameters of the equivalent and the supply circuits has been developed. Developed program gives possibility to quickly compute the motor characteristics when it is placed in any borehole depth at various environment and borehole medium temperatures.

References

1. **Gečys S., Kripas M., Katkevičius V.** Losses of Electrical Motor for Borehole Investigating Mechatronical Devices // *Electronics and Electrical Engineering – Kaunas: Technologija*, 2005.- No. 2 (58). – P. 65 – 69 (in Lithuanian).
2. **Gečys S., Gudžius S., Morkvėnas A.** The Influence of complex supply circuit parameters on electrical motors characteristics for borehole investigating devices // *Proceedings of the XIII International Conference on Electromagnetic Disturbances, “Overvoltages in power - electronic - computer - engineering” 24-26 September 2003, Bialystoc, Poland.– Kaunas: Technologija*, 2004.–P.229–232.
3. **Kucevalov V. M.** *Asynchronous and Synchronous Machines with Solid Rotors.* Moscow: Energy, 1979. – 160 p. (in Russian).
4. **Gečys S., Kalvaitis A.** Estimation Criteria of Torque-slip Characteristic of Motors for Geophysical Devices // *Electronics and Electrical Engineering Kaunas: Technologija*, 2002.- No. 4 (39).–P. 42–46 (in Lithuanian).

Presented for publication 2006 03 20

S. Gečys, P. Smolskas. Critical Slip and Characteristics of Induction Motor for Borehole Investigating Devices // Electronics and Electrical Engineering. – Kaunas: Technologija, 2006. No. 4(68). P. 95–98.

If the borehole medium temperature did not exceed +200°C, it is successfully used single-phase asynchronous capacitor motor with solid ferromagnetic rotor for the borehole investigating device drive. For the boreholes of which medium temperature exceeds +200°C it is expedient to use two-phase or three-phase induction motor with solid ferromagnetic rotor. There are presented the critical slip and maximum electromagnetic power expressions of the symmetric induction motor with solid ferromagnetic rotor taking into account the inner complex impedance of the power-supply source and the distributed parameters of the long geophysical cable. It has been proved that derived critical slip expression is the general case of a critical slip formula. The algorithm for the study of motor characteristics taking into account the parameters of the equivalent and the supply circuits is presented. Developed program gives possibility to compute the motor characteristics when it is placed in any borehole depth at various environment and borehole medium temperatures. Ill. 4, bibl. 4 (in English; summaries in English, Russian and Lithuanian.).

С. Гячис, П. Смольскас. Критическое скольжение и характеристики асинхронного двигателя для геофизических скважинных устройств // Электроника и электротехника. Каунас: Технология, 2006. № 4(68). P. 95–98.

Однофазный асинхронный конденсаторный двигатель с массивным ротором успешно применен в приводе геофизического скважинного устройства при температуре среды в скважине до +200°C, но при температуре превышающей +200°C целесообразно использовать двухфазный или трехфазный двигатель с массивным ротором. Представлены выражения для критического скольжения и максимальной электромагнитной мощности асинхронного двигателя с массивным ротором, учитывая внутреннее сопротивление источника питания и распределенные параметры длинного геофизического кабеля. Доказано, что выведенное выражение критического скольжения, является общим случаем известной формулы критического скольжения. Представлен алгоритм расчета характеристик двигателя, учитывая параметры схемы замещения и цепи питания. Составлена программа для расчета характеристик двигателя для любой глубины скважины и при разных температурах окружающей среды и среды в скважине. Ил.4, библи. 4 (на английском языке; рефераты на английском, русском и литовском языках).

S. Gečys, P. Smolskas. Gręžinių tyrimo prietaisų asinchroninio variklio kritinis slydimas ir charakteristikos // Elektronika ir elektrotechnika. – Kaunas: Technologija, 2006. Nr. 4(68). P. 95–98.

Kol gręžinio terpės temperatūra neviršija +200°C, jo tyrimo įtaiso pavarai sėkmingai naudojamas vienfazis asinchroninis kondensatorinis variklis su vientisuuju feromagnetiniu rotoriumi, o kai viršija – tikslinga naudoti dvifazį ar trifazį asinchroninį variklį su vientisuuju feromagnetiniu rotoriumi. Pateiktos asinchroninio variklio su vientisuuju feromagnetiniu rotoriumi kritinio slydimo ir maksimaliosios elektromagnetinės galios išraiškos, atsižvelgiant į maitinimo šaltinio vidaus varžą ir ilgo geofizikos kabelio paskirstytuosius parametrus. Įrodyta, kad išvestoji kritinio slydimo išraiška yra bendrasis žinomos kritinio slydimo formulės atvejis. Pateiktas variklio charakteristikų skaičiavimo algoritmas atsižvelgiant į ekvivalentinės schemos ir maitinimo grandinės parametrus. Sudaryta programa apskaičiuoti variklio charakteristikas bet kuriame gręžinio gylyje prie įvairių aplinkos ir gręžinio terpės temperatūrų. Il.4, bibl.4 (anglų kalba; santraukos anglų, rusų ir lietuvių kalbomis).

DOI: 10.5755/j02.eie.10663