

## Investigation into Dynamic Non-Symmetrical Braking Modes of Linear Induction Motor

R. Rinkevičienė, S. Lisauskas, A. Šlepikas

Automation department, Vilnius Gediminas Technical University,

Naugarduko str. 41, LT-03227 Vilnius, Lithuania, tel. +370 5 2744763, e-mail: saulius.lisauskas @el.vtu.lt

### Introduction

Any technological equipment is characterized by proper operational parameters, which are set as requirements in elaborating mechatronic system with linear induction motors. As the linear induction motor (LIM) has worse efficiency, the advantage of mechatronic with LIM appears just in the case when LIM is designed for proper equipment singly and becomes a concurrent part of that. It is underlined in [1] that dynamic features of electric drive with LIM are always better than rotating that due to smaller inertia of moving parts. As the linear electric drive has less number of mechanical elements, its elasticity is smaller. Linear electric drive has no reducer present; therefore the linear drive has no clearance. Due to these features dynamic characteristics of the linear induction drive are better. Dynamic processes of the electric drive with linear induction motors include all types of possible transition processes, between them and braking those.

Braking mode of LIM compose a separate problem. Braking performance of polyphase flat double sided LIM with non-magnetic secondary has been analyzed in [2] using field theory techniques. The analysis based on the solution of quasi-one-dimensional electromagnetic field distribution in the air gap is presented in [3].

Stationary mode of LIM braking is considered in [4] and the schemes of LIM winding connection at braking performance are proposed in [5]. Articles [2, 3, 4] give steady state dependences between the force, developed by LIM and LIM speed. The dynamic performance of linear induction drive with different connection of LIM windings at braking is considered in [6, 7, 8, 9]. The braking with direct current is analyzed in [6]. The problems of single phase braking are considered in [7, 8].

Simple construction of linear motor allows to change its parameters and developed force in simply way. For example, the secondary element, made from different materials, is characterized by different reduced resistance, which changes the force-speed characteristics of LIM.

The article discusses dynamic performance of the electric drive with LIM at direct current braking. Influence of the secondary resistance for braking characteristics at different ways of LIM windings connection is analyzed.

### Model of the linear induction motor at direct current braking mode

If the LIM is supplied by balanced three phase voltage and all the phase impedances of the LIM are assumed to be equal, then it's mathematical and computer models, designed in moving with synchronous speed and stationary reference frame, are presented in [9]. These models give possibility to simulate motoring and reverse-current braking modes. At LIM operation in direct current braking mode, the possible ways to supply the LIM windings by direct current voltage is shown in Fig. 1 [5]. The circuits presented in the Fig. 1 indicate, that LIM during braking is supplied by unbalanced voltage, therefore the way of LIM windings connection must be considered during elaboration of LIM dynamic models for braking.

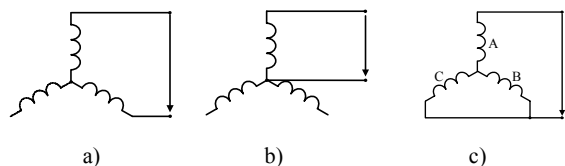


Fig. 1. The schemes of LIM windings connection at direct current braking mode

The model to investigate unbalanced dynamic modes of linear induction drive is designed on the base of symmetrical components, which employs the expanding of any unbalanced voltage to three symmetrical components. According to this, the model of braking mode contains three models, developed for direct, reverse and zero components of supply voltage (Fig. 2). The differential equations of LIM, supplied by direct component, are presented in [9]. The equations of LIM, supplied by reverse component, are derived in [10].

Simulation gives time response of force, developed by motor, speed and current. The starting process is modelled at operating just one direct component of voltage. This corresponds to starting of LIM with supply by symmetrical voltage. At direct current braking all three components present in the model.

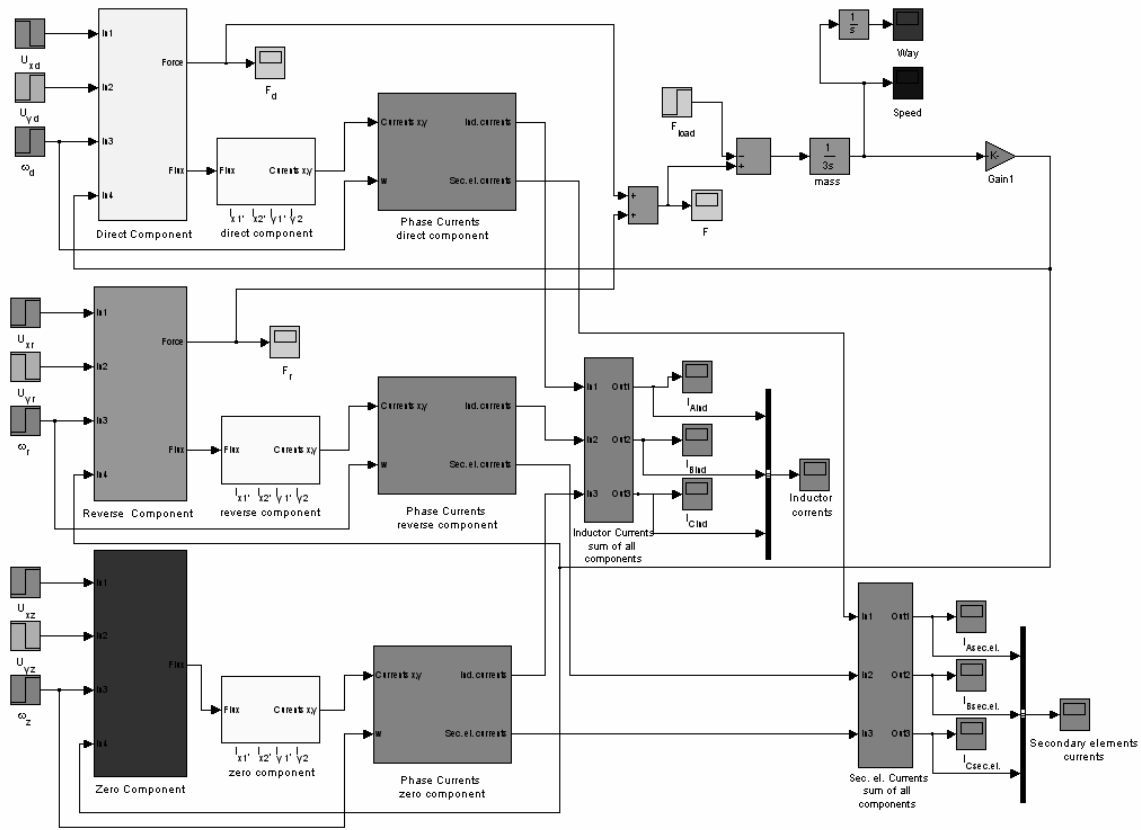


Fig. 2. The model of LIM direct current braking

At this time instant frequency of supplied voltage components is set equal to zero.

Components of LIM inductor current  $I_{x1}, I_{y1}$  are calculated as:

$$I_{x1} = \alpha'_s (\Psi_{x1} - \Psi_{x2} K_r) \frac{U_1}{R_1}; \quad (1)$$

$$I_{y1} = \alpha'_s (\Psi_{y1} - \Psi_{y2} K_r) \frac{U_1}{R_1}.$$

Phase current  $I_A$  is found as:

$$I_A = I_{x1} \cos \omega_0 t - I_{y1} \sin \omega_0 t, \quad (2)$$

where  $U_1$  is applied voltage,  $R_1$  is inductor resistance and  $\Psi_{x1}, \Psi_{y1}$  are inductor flux linkage components,  $\Psi_{x2}, \Psi_{y2}$  is secondary element flux linkage components,  $K_r$  is coefficient depending on ratio of inductor and secondary element parameters and  $\omega_0$  is angular frequency.

Model to calculate components of LIM currents is given in Fig. 3.

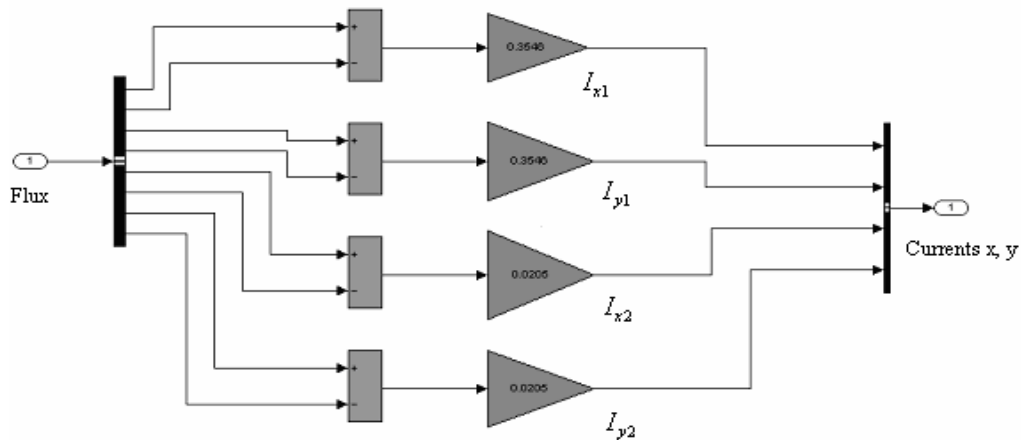
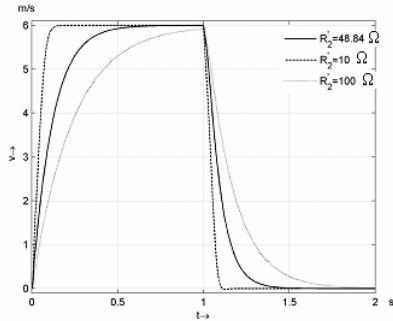


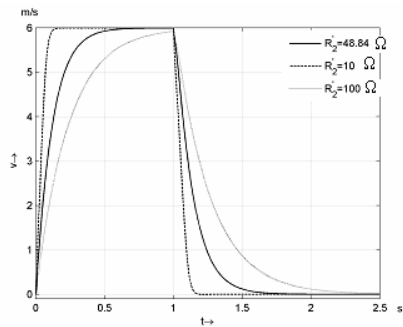
Fig. 3. Model to calculate components of currents  $I_{x1}, I_{y1}, I_{x2}, I_{y2}$

## Simulation results

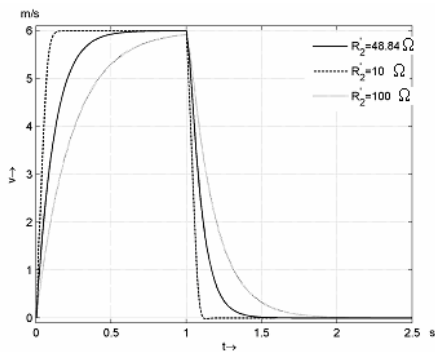
Fig. 4-6 indicate the starting and braking processes of electric drive with LIM at the same direct current voltage and different ways of inductor windings connection at braking. The other changeable parameter is reduced resistance of the secondary element. The rated value is  $R_2' = 48,84 \Omega$  for real frequency controlled LIM. Application of LIM secondary elements, made from materials with different resistivity, allows changing  $R_2'$  very simply. Mentioned figures show reduced  $R_2'$  causing shorter braking time for all inductor windings connection modes.



**Fig. 4.** LIM speed at direct current braking voltage 110 V, connected according to Fig. 1a and different values of secondary element resistance

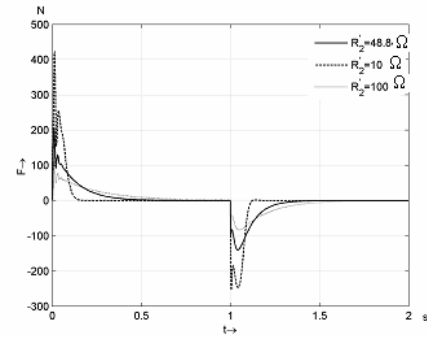


**Fig. 5.** LIM speed at direct current braking voltage 110 V, connected according to Fig. 1b and different values of secondary element resistance

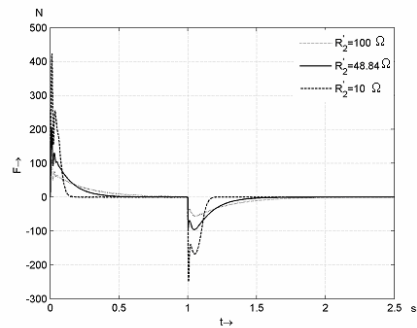


**Fig. 6.** LIM speed at direct current braking voltage 110 V, connected according to Fig. 1c and different values of secondary element resistance

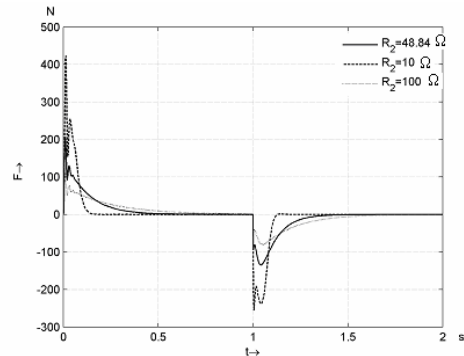
Fig. 7-9 indicate the force developed by LIM during starting and braking when different ways of inductor windings connection are present and different resistance of secondary element  $R_2'$ . They show the greater braking force to be developed at attachment of voltage just to one LIM winding (Fig. 7). Supply of direct current voltage to series connection of two windings give the smallest braking force as well as to series parallel connection of windings gives about 20% greater than latter. Therefore the braking time is the smallest for the circuit shown in Fig. 1a.



**Fig. 7.** Force developed by LIM at direct current braking voltage 110 V, connected according to Fig. 1a and different values of secondary element resistance



**Fig. 8.** Force developed by LIM at direct current braking voltage 110 V, connected according to Fig. 1b and different values of secondary element resistance



**Fig. 9.** Force developed by LIM at direct current braking voltage 110 V, connected according to Fig. 1c and different values of secondary element resistance

## Conclusions

1. Developed model gives possibility to investigate dynamic characteristics at braking of LIM by direct current, if braking voltage is attached to LIM windings, connected in different ways and evaluate influence of LIM parameters to dynamics of braking.
2. Braking time depends on the way of windings connection and resistance of the secondary element. The greatest braking force and the smallest braking time are obtained at the supplying by direct current voltage just one phase winding.
3. The other two considered circuits for supply braking voltage give approximately the same values of braking time and the greatest braking force.

## References

1. **Budig P. K.** The application of linear motors. The third International Power Electronics and motion Control conference. – 2000. – Vol.3. – P. 1336–1341.
2. **Pai R. M.** DC dynamic braking performance of linear induction motor. *Electric machines and Power Systems*. V. 15, No 2. 1988. – P. 65–72.
3. **Pienkowski K.** Dynamic braking performance of double-sided linear induction motors. *Modelling, Simulation & Control A: General Physics (Matter and waves), Electrical & Electronics Engineering*. – 1987. – V. 13, No 2. – P. 13–22.
4. **Smilgevičius A.** Tiesiaiegių asinchroninių variklių stabdymo tyrimai Lietuvoje // *Elektronika ir elektrotechnika*. ISSN

- 1392-1215. – Kaunas: Technologija, 2005. – Nr. 1(57). – P. 42–47.
5. **Smilgevičius A.** Tiesiaiegių asinchroninių variklių stabdymas. – V.: Technika, 1992. – 52 p.
6. **Rinkevičienė R., Lisauskas S.** Dinaminiai tiesiaiegių pavarų stabdymo režimai // *Elektronika ir elektrotechnika*. – Kaunas: Technologija, 2005. – Nr. 4(60). – P. 38–41.
7. **Rinkevičienė R., Lisauskas S., Petrovas A.** Dynamic modes of single phase braking of linear induction motors. 3<sup>rd</sup> International Symposium “Topical problems of education in the field of electrical and power engineering” Doctoral school of Energy and geotechnology. – Kuressaare, 2006. – P. 72–77.
8. **Rinkevičienė R., Lisauskas S.** Tiesiaiegių elektros pavaros vienfazio stabdymo dinaminis modelis// *Energetikos ir elektrotechnikos technologijos: Konferencijos pranešimų medžiaga*. – Kaunas. 2005. – P. 122–127.
9. **Rinkevičienė R., Lisauskas S.** Tiesiaiegių mechatroninių sistemų modeliai // *Elektronika ir elektrotechnika*. ISSN 1392-1215. – Kaunas: Technologija, 2003. – Nr. 4(46). – P. 69–73.
10. **Rinkevičienė R., Lisauskas S.** Tiesiaiegio asinchroninio variklio nesimetrinių dinaminį stabdymo režimų tyrimas. *Elektronika ir elektrotechnika. Electronics and Electrical Engineering*. – Kaunas: Technologija, 2006. – Nr. 1(65). – P. 60–63.

Presented for publication 2006 02 10

### **R. Rinkevičienė, S. Lisauskas, A. Šlepikas. Investigation into Dynamic Non-Symmetrical Breaking Modes of Linear Induction Motor // *Electronics and Electrical Engineering*. – Kaunas: Technologija, 2006. – No. 4(68). – P. 59–62.**

The paper presents investigation into non-symmetrical dynamic breaking modes. The non-symmetrical model of linear induction drive with different connection of inductor windings at dynamic braking is presented. Model comprises three models of linear induction drive made for direct, inverse and zero components of supply voltage. Developed model gives possibility to investigate starting process and dynamic characteristics by direct current braking, compare dynamic characteristics and evaluate influence of motor parameters to that. Presented results of simulation show the force, developed by motor and braking time dependence on the resistance of secondary element. The greatest braking force and the smallest braking time are obtained at the supplying by braking voltage one phase winding. Ill. 9, bibl. 10 (in Lithuanian, summaries in English, Russian and Lithuanian).

### **Р. Ринкявичене, С. Лисаускас, А. Шляпикас. Исследование несимметрических динамических режимов торможения линейного асинхронного двигателя // *Электроника и электротехника*. – Каунас: Технология, 2006. – №. 4(68). – С. 59–62.**

Исследуются несимметрические динамические режимы торможения линейного асинхронного двигателя (ЛАД). Разработана компьютерная модель ЛАД при разном соединении обмоток при торможении постоянным током. Модель состоит из трех моделей ЛАД, разработанных для прямой, обратной и нулевой последовательности напряжения питания. Разработанный модель позволяет исследовать пусковой и динамический режим торможения постоянным током линейного асинхронного двигателя, сравнить характеристики и исследовать влияние параметров двигателя. Представленные результаты имитации при разном соединении обмоток для подачи постоянного тока показывают зависимость от сопротивления вторичного элемента, и максимальное усилие торможения и наименьшая длительность торможения поучается при подачи напряжения постоянного тока на одну фазную обмотку двигателя. Ил. 9, библи. 10 (на литовском языке; рефераты на английском, русском и литовском яз.).

### **R. Rinkevičienė, S. Lisauskas, A. Šlepikas. Tiesiaiegio asinchroninio variklio nesimetrinių dinaminį stabdymo režimų tyrimas // *Elektronika ir elektrotechnika*. – Kaunas: Technologija, 2006. – Nr. 4(68). – P. 59–62.**

Nagrinėjami tiesiaiegio asinchroninio variklio dinaminiai stabdymo nuolatine srove režimai. Pateikiamas tiesiaiegių elektros pavaros modelis, gautas skirtingais būdais jungiant variklio apvijas stabdymo metu. Modelį sudaro trys TAV modeliai, kurie atitinka simetrines tiesioginę, atvirkštinę ir nulinę variklio įtampos dedamąsias. Sukurtas modelis variklio paleidimo ir dinaminio stabdymo režimams tirti, gautoms charakteristikoms palyginti, variklio parametrų įtakai dinaminėms charakteristikoms įvertinti. Pateikti stabdymo nuolatine srove režimų imitacijos rezultatai esant skirtingiems variklio apvijų jungimo būdams stabdymo metu rodo, kad stabdymo trukmė ir sukuriama stabdymo jėga priklauso nuo antrinio elemento varžos. Didžiausia stabdymo jėga ir mažiausia trukmė gaunama, kai nuolatine įtampa prijungiama tik prie vienos variklio fazinės apvijos. Il. 9, bibl. 10 (lietuvių kalba; santraukos anglų, rusų ir lietuvių k.).

DOI: 10.5755/j02.eie.10653