

## Selection of the Magnetic Circuit Design for Electromagnetic Fluid Flow Converter with Rectangular Channel

R. Padegimas, J.A. Virbalis

Department of Theoretical Electrotechnics, Kaunas University of Technology,  
Studentų str. 48, LT-51367 Kaunas, Lithuania, tel. +370-37-300267, e-mail: arvydas.virbalis@ktu.lt

R. Vaikasas

Scientific-Industrial Company „Katra“,  
Kulautuvos str. 45, LT-47190 Kaunas tel. +370 37 267196, e-mail: r.vaikasas@katra.lt

### Introduction

The exploitation experience of different electromagnetic fluid flow converters (EMFC) shows increasing attention to the primary flow sensors with rectangular channel (see Fig. 1). The main advantage of these sensors is the significantly lower dependence of the electrodes signal on a velocity distribution (velocity profile) in the cross-section of the channel. M. Bevir [1] proved that this dependence is absent, when the magnetic field is uniform and rectangular electrodes or rod-shaped electrodes are used. Other advantage of rectangular channel is the larger average value of the magnetic field in the active area of the sensor comparing with the magnetic field created by the same exciting coil and the same electric current in a sensor with circular channel, i.e. the sensitivity of the sensors with rectangular channel is higher than the sensitivity of sensors with circular channel.

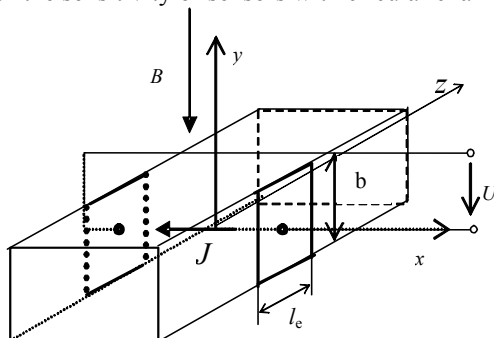

Fig. 1. Electromagnetic fluid flow sensor with a rectangular channel

Real magnetic field is not uniform and depends on the design of the exciting coils, therefore the signal of electrodes is sensitive to the velocity distribution. We shall discuss which design of the exciting coils ensures the minimal interrelation between the signal of electrodes and the fluid velocity profile. We analyse a three-dimensional

problem. The shape of electrodes is rectangular, too. Their height is always equal to the height of the channel  $b$ , the width  $l_e$  is variable. In the case  $l_e \rightarrow 0$  the electrodes shape is a rod.

We use rectangular coordinate system. The axis  $x$  coincides with the straight line going through the geometric centres of the electrodes and the axis  $z$  coincides with the geometrical axis of the fluid channel. The magnetic circuit of sensor must be designed to direct magnetic field along the axis  $y$ . The signal  $U$  created by such flow transducer may be expressed as follows [1]:

$$U = \int_{\tau} (\mathbf{J} \times \mathbf{B})_z v_z d\tau = \int (J_x B_y - J_y B_x) v_z d\tau, \quad (1)$$

where  $\mathbf{J}$  is a density of a virtual current (it is calculated in the same way as the distribution of the unit current that flows from one electrode to other electrode in the active area when there is no fluid flow),  $\tau_a$  – volume of the active area;  $d\tau$  – the volume element.

Presume that the distribution of the magnetic flux density  $\mathbf{B}$  and virtual-current density satisfy usual conditions of symmetry:

$$\begin{cases} J_x(x, y, z) = J_x(-x, y, z) = J_x(x, -y, z) = J_x(x, y, -z) = J_x(-x, -y, z) = \\ = J_x(-x, y, -z) = J_x(x, -y, -z) = J_x(-x, -y, -z), \\ J_y(x, y, z) = -J_y(-x, y, z) = -J_y(x, -y, z) = J_y(x, y, -z) = J_y(-x, -y, z) = \\ = -J_y(-x, y, -z) = -J_y(x, -y, -z) = J_y(-x, -y, -z), \end{cases} \quad (2)$$

$$\begin{cases} B_x(x, y, z) = -B_x(-x, y, z) = -B_x(x, -y, z) = B_x(x, y, -z) = B_x(-x, -y, z) = \\ = -B_x(-x, y, -z) = -B_x(x, -y, -z) = B_x(-x, -y, -z), \\ -B_y(x, y, z) = B_y(-x, y, z) = B_y(x, -y, z) = B_y(x, y, -z) = B_y(-x, -y, z) = \\ = B_y(-x, y, -z) = B_y(x, -y, -z) = B_y(-x, -y, -z). \end{cases} \quad (3)$$

In this case the products of  $J_x B_y$  and  $J_y B_x$  will be of the same sign in all eight octants.

We shall define EMFC sensitivity  $S$  as the ratio between the signal  $U$ , expressed by (1), with the average speed of flow  $\bar{v}$  in the cross-section:

$$S = \frac{U}{\bar{v}}. \quad (4)$$

We investigate the dependence of the sensitivity  $S$  on the design of the magnetic field exciting coils and on the speed profile.

### Comparison of Electromagnetic Flow Sensors of Circular and Rectangular Channels

We compare the sensitivities of the EMFC with the round and rectangular channel. The cross-sections of channels, intersecting centres of electrodes, are shown in Fig. 2, a and b. Because the source of the magnetic field is outside of the active area, we can use scalar magnetic potentials  $V_m$  and  $-V_m$  (the potentials are created by the exciting coils of the magnetic field) for the analysis. We analyse only the magnetic field, created by round coil, inside the cylinder (Fig. 2, c) and created by rectangular coil - inside the rectangular parallelepiped (Fig. 2, d). These shapes are limited by the conductive magnetic surfaces of the upper and lower exciting coils cores. The design of the channel and magnetic core may be different, i.e. the sensors with round or rectangular channel may have cylindrical or rectangular magnetic core.

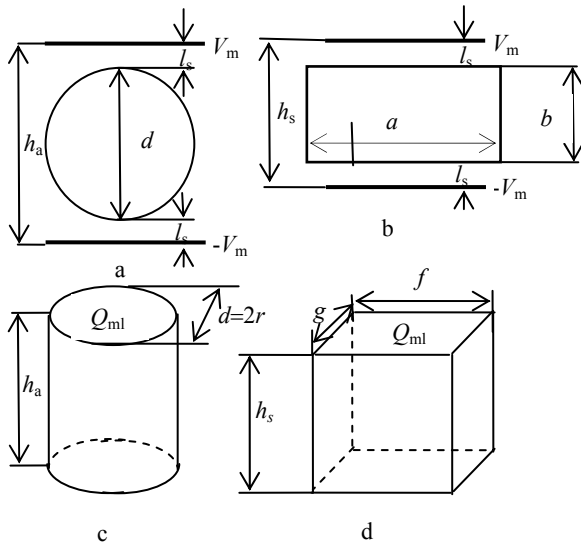

**Fig. 2.** Dimensions of round (a), rectangular (b) channels and calculation area of magnetic field created by of round (c) and rectangular (d) magnetic core

Let the area of the magnetic core surfaces, that limits the shapes c and d from top and bottom, be equal to  $Q_{ml}$  as well as the magnetic field be uniform and length  $h$  of all lines of magnetic field be equal to the distance between the poles of the cores ( $h=h_a$  - for round channel and  $h=h_s$  - for rectangular channel). The magnetic resistance of these areas may be expressed this way:

$$R_m = \frac{h}{\mu_0 Q_{ml}}, \quad (5)$$

The magnetic flux density may be expressed by using the Ohm's Law:

$$B = \frac{\Phi}{Q_{ml}} = \frac{2V_m}{Q_{ml}R_m} = \frac{2V_m}{Q_{ml} \frac{h}{\mu_0 Q_{ml}}} = \frac{2V_m \mu_0}{h}. \quad (6)$$

When the inductors of magnetic of the EMFC with the round and rectangular channel have the same number of turns and the same current, the same difference of magnetic potentials  $2V_m$  is created. Thus the ratio between the magnetic flux density of rectangular channel  $B_s$  and magnetic flux density of round channel  $B_a$  is inversely proportional to the ratio of the distances between the poles of the cores:

$$K_{sa} = \frac{B_s}{B_a} = \frac{2V_m \mu_0 / h_s}{2V_m \mu_0 / h_a} = \frac{h_a}{h_s}, \quad (7)$$

where  $h_a = d + 2l_s$  - for cylindrical channel and  $h_s = b + 2l_s$  for rectangular channel,  $d$  - diameter of cylindrical channel,  $b$  - height of rectangular channel,  $l_s$  - distance at core pole to inner surface of channel (see Fig.2, a and b). This ratio approximately expresses ratio between sensitivities of the EMFC with the round and rectangular channel. We compare the flow transducers used for the measurement of the same flow, i.e. flow transducers with the same cross-section area  $Q_k$ . The cross-section area of the round channel is  $Q_{ka} = \pi(d/2)^2$ , and the cross-section of the rectangular channel is  $Q_{ks} = ba = b^2(a/b)$ . By equality  $Q_{ka} = Q_{ks}$  the relation between the diameter  $d$  of cylindrical channel and the parameter  $b$  of the rectangular channel can be established:

$$d = 2\sqrt{\frac{a/b}{\pi}} \cdot b. \quad (8)$$

The coefficient  $K_{sa}$  can be expressed of (7) and (8):

$$K_{sa} = \frac{2\sqrt{\frac{a/b}{\pi}} \cdot b + 2l_s}{b + 2l_s} = 2\sqrt{\frac{a/b}{\pi}} - \frac{2\sqrt{\frac{a/b}{\pi}} - 1}{b/2l_s + 1}. \quad (9)$$

When  $a/b=2$ , diameter of the round channel  $d=50\text{mm}$ , and  $l_s=3\text{mm}$ , we obtain  $K_{sa} \approx 1,5$ .

The peripheral magnetic field is not evaluated in expression (9). The lines of the peripheral field are longer than  $h_a$  and  $h_s$ , correspondingly, and their ratio is nearer to one. Therefore, the expression (9) gives the maximal evaluation of coefficient  $K_{sa}$ .

### Design of the Sensor

Further we analyse only the EMFC with the rectangular channel. The magnetic conductors may have cylindrical or rectangular shape. Our goal is to find out

which of the designs of the magnetic conductors is better for measurement of the fluid flow in the wide range of flow. We select similar perimeters for the cylindrical and rectangular magnetic core. In such case the coils shall have the same number of turns when the wires of the same length are used. Therefore, if these coils are subjected to the same exciting current, the same magnetomotive force is created. We can compare the sensitivities of the sensors with the same consumption of materials and energy in magnetic field exciting coils.

The area of the circle is always larger than the area of a rectangle of the same perimeter. The difference between the areas increases with increase of relation  $f/g$  (see Fig. 2, d). By this cause the sensitivity of EMFC with the rectangular core must be smaller, than the sensitivity of EMFC with the cylindrical core and the same consumption of materials and energy. However, in case of rectangular magnetic cores, the maximal magnetic field between the poles of the cores is created in a narrowest area in which the density of virtual current is highest. This circumstance increases the sensitivity of the sensor. Such tendency becomes more evident when the length  $f$  of side along the straight line, connecting the centres of electrodes, is longer than the length  $g$  of side, perpendicular to the side  $f$  and the electrodes shape are close to a rod. Therefore, there are the two factors with contrary influence to the sensor sensitivity, however only analysis would help to find an answer to the question which of the factors is the most significant. We have performed the analysis by finite elements method.

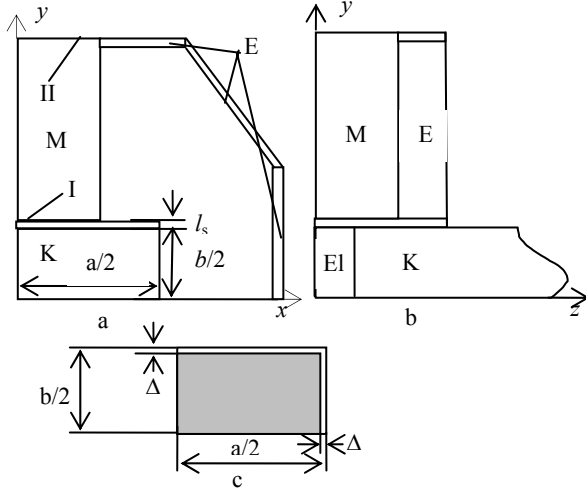

**Fig. 3.** Cross – sections of electromagnetic fluid flow transducer  $xy$  (a) and  $yz$  (b) in the plane and analysing cross - section part of channel (c).

Typical design of the sensor with a rectangular channel is the symmetrical one with regard of all three axes, therefore it is enough to analyse only one octant of channel. The cross-sections in the planes  $z=0$  and  $x=0$  are shown in Fig. 3. In this figure K - channel, M – magnetic conductor inside exciting coil, E – magnetic screen, El - electrode. The magnetic core may have a rectangular or cylindrical shape depending on the design of the coil.

The design of the sensor was simulated by using software COSMOS/M. The body was divided by cubes of

the same size (the side length of cube was equal to  $\Delta$ ). Two problems were solved: problem of electric current distribution and problem of magnetic field distribution in the channel. The current problem was solved by subjecting a potential  $V_e$  to the electrode as well as the potential  $V=0$  to the plane  $x=0$ . Magnetic problem was solved with a presumption that the magnetic potential of the plane  $y=0$  is  $V_m=0$ , the magnetic potential of the surface of the magnetic conductor I (see Fig. 3, a) is  $+V_m$  and the magnetic potential of the magnetic conductor II (see Fig. 3, a) is  $-V_m$ .

The signal was calculated for laminar as well as for turbulent flow. In the case of laminar flow, the speed of the fluid is distributed according to the parabolic law:

$$v(x_s, y_s) = K_p(1-x_s^2)(1-y_s^2), \quad (9.1)$$

where  $K_p$  is normalisation coefficient. Its calculated value must be such as to ensure the average fluid velocity  $\bar{v}$  equal to 1m/s. The sensitivity  $S$  can be calculated using the equation (4) in this case. Coordinates  $x_s$  and  $y_s$  can be expressed as follows:

$$x_s = \frac{x}{a/2}, \quad (10)$$

$$y_s = \frac{y}{b/2}.$$

In the case of turbulent flow, if the Reynolds's number  $Re$  is within the range  $[4 \cdot 10^3, 3.2 \cdot 10^6]$ , the fluid velocity can be expressed this way [3]:

$$v(x_s, y_s) = K_n(1-x_s)^{1/n}(1-y_s)^{1/n}. \quad (11)$$

The number  $n$  and normalization coefficient  $K_n$  depend on the Reynolds's number. The relationship between  $n$  and  $Re$  is shown in the Table 1.

**Table 1.** Relationship between  $n$ ,  $K_n$  and  $Re$ .

Re	$4 \cdot 10^3$	$1.1 \cdot 10^5$	$1.1 \cdot 10^6$	$(2 \div 3.2) \cdot 10^6$
$N$	6	7	8,8	10
$K_n$	1.277	1.253	1.217	1.197

To compare the sensitivity of EMFC for different distribution of fluid velocity in the cross-section, the normalization coefficient  $K_n$  was calculated accepting, that  $\bar{v} = 1 \text{ m/s}$  for any  $n$ . The evaluation of the electrode signal is more precise when the signal is calculated for the entire cross-section, except those elements that intersect with other areas. Average value of the fluid velocity in one quarter of the cross-section is expressed as follows:

$$\bar{v} = \frac{1}{S} \int_0^{x_r} \int_0^{y_r} v(x_s, y_s) dx_s dy_s. \quad (12)$$

We can express  $a/2 = k\Delta$ ,  $b/2 = l\Delta$ . Then

$$x_r = \frac{(k-1)\Delta}{k\Delta} = \frac{k-1}{k}, \quad y_r = \frac{(l-1)\Delta}{l\Delta} = \frac{l-1}{l}. \quad (13)$$

The area of the quarter of the discussed cross-section is:

$$S = x_r y_r = \frac{(k-1)(l-1)}{kl}. \quad (14)$$

After insertion of (9) into (12) and integration, evaluating (13) and (14), we can express  $K_p$  for  $\bar{v} = 1 \text{ m/s}$ :

$$K_p = \frac{9}{[3 - (1-1/k)^2][3 - (1-1/l)^2]}. \quad (15)$$

Simulation was made accepting, that  $k=19$  and  $l=13$ . In this case  $K_p=1.993$ .

The  $K_n$  can be expressed into (12) inserting (11) instead of (9):

$$K_n = \left(\frac{1+n}{n}\right)^2 \frac{(k-1)(l-1)}{(kl)^{1/n} (k^{n/n+1} - 1)(l^{n/n+1} - 1)}. \quad (16)$$

The values of  $K_n$  calculated for  $k=19$ ,  $l=13$  and relevant values of  $n$  are indicated in the Table 1.

### Parameters of the compared designs

During simulation the comparison of the relationship between the electrode signals and velocity profile was made for cylindrical core and rectangular core. The sensor with a rectangular channel of  $19 \times 29 \text{ mm}^2$ , produced by the Company „Katra“, was analysed. The nominal flow of the sensor is nearly the same as the flow of the round channel  $d_k=50 \text{ mm}$ .

The comparison of the electrode signals was made, when the cylindrical magnetic core with the diameter  $d_m=24 \text{ mm}$  and rectangular magnetic core with the following dimensions:  $32 \times 8 \text{ mm}^2$ ,  $28 \times 12 \text{ mm}^2$  and  $24 \times 16 \text{ mm}^2$  were used in the sensor. The perimeter of the rectangular magnetic core is the same, i.e.  $P_s=80 \text{ mm}$ . However the perimeter of the round magnetic conductor is slightly smaller:  $P_a=24\pi=75.4 \text{ mm}$ . The ratio of these perimeters:

$$A = \frac{P_s}{P_a} = \frac{80}{75.4} = 1.061.$$

In case the same length of wire would be used for the round magnetic conductor, the number of turns would be by 6.1% larger than the number of windings of the rectangular magnetic conductor. Thus we can conclude that the magnetomotive force would be also higher by 6.1% at the same consumption of materials and energy. Due to this reason the magnetic potential of the round magnetic-conductor was calculated by multiplying the magnetic potential  $U_m$  of the rectangular magnetic-conductor with a multiplier  $A$ .

If the perimeters of the round and rectangular magnetic conductors are the same, then the volume of the round magnetic conductor will be larger comparing with the volume of rectangular magnetic conductor. The volume

coefficient  $K_T$  can be expressed this way:

$$K_T = \frac{V_s}{V_a} = \frac{fgh}{(\pi d^2/4)h} = \left(\frac{f}{d}\right)^2 \frac{g/f}{\pi/4}. \quad (17)$$

The ratio  $f/d$  can be expressed by equality of the perimeters  $\pi d=2(f+g)$ :

$$\frac{f}{d} = \frac{\pi}{2(1+g/f)}. \quad (18)$$

After insertion of the equation (18) into the equation (17), the following  $K_T$  expression is obtained:

$$K_T = \frac{\pi(g/f)}{(1+g/f)^2}. \quad (19)$$

This coefficient shows what part of the round magnetic conductor volume has the rectangular magnetic conductor volume, when the same magnetomotive force is obtained in the both cases.

### Simulation results

The distribution of the flow speed was varied from parabolic (i.e. laminar flow) to the turbulent flow with  $Re=3.2 \cdot 10^6$ . This analysis practically covers almost all possible operation modes of the fluid flow transducers. The simulation was performed by using rod electrodes. The calculated electrode signal  $U_s$  was obtained approximating the integral (1) by the following equation:

$$U_s = \sum_{m=1}^{m_{\max}} (J_{xm} B_{ym} - J_{ym} B_{xm}) v_m, \quad (20)$$

where  $m_{\max}$  – total number of elements used for formation of the signal. The velocity  $v_m$  in case of laminar flow was calculated this way:

$$v_m = K_p \left[1 - \left(\frac{m-M}{k}\right)^2\right] \left[1 - \left(\frac{M-N}{l}\right)^2\right], \quad (21)$$

In the turbulent flow case the velocity  $v_m$  was calculated by this expression:

$$v_m = K_n \left[1 - \left(\frac{m-M}{k}\right)^{\frac{1}{n}}\right] \left[1 - \left(\frac{M-N}{l}\right)^{\frac{1}{n}}\right]. \quad (22)$$

In the (21) and (22) equations:

$$M = E\left\{\frac{m}{k}\right\}, \quad N = E\left\{\frac{M}{l}\right\}, \quad (23)$$

where  $E\{x\}$  is a integer part of the number  $x$ .

The simulation results are indicated in the Table 2. The results of the calculations of volume coefficient are also indicated in the table below.

**Table 2.** Electrode signals by using different cores and rod-shaped electrodes

Type of flow	Turbulent flow					Parabolic flow	$K_T$
	$U_s$	Re=3.2·10 <sup>6</sup>	Re=1.1·10 <sup>6</sup>	Re=1.1·10 <sup>5</sup>	Re=4·10 <sup>3</sup>		
Cylindrical magnetic conductor	$U_s$	1906	1907	1909	1911	1996	1.0
	$\Delta U_s, \%$	-1.0	-0.97	-0.86	-0.75	3.7	
Rectangular magnetic conductor 32×8	$U_s$	1878	1875	1868	1862	1833	0.503
	$\Delta U_s, \%$	0.79	0.63	0.26	0.06	-1.6	
Rectangular magnetic conductor 28×12	$U_s$	1882	1880	1876	1872	1871	0.660
	$\Delta U_s, \%$	0.31	0.20	-0.01	-0.22	-0.28	
Rectangular magnetic conductor 26×14	$U_s$	1916	1914	1912	1910	1933	0.715
	$\Delta U_s, \%$	-0.05	-0.16	-0.26	-0.37	0.83	
Rectangular magnetic conductor 24×16	$U_s$	1927	1927	1926	1926	1973	0.754
	$\Delta U_s, \%$	-0.45	-0.45	-0.51	-0.51	1.9	

We can see that sensitivities of EMFT with the rectangular and cylindrical magnetic cores are similar. But the interrelation between the electrode signal and fluid velocity profile in the wide range of average velocities is smaller in the EMFT with the rectangular than in the EMFT with the cylindrical magnetic core. The deviation from the average value of the signal is within the range [-0,28%, 0,31%] in case of rectangular magnetic conductor 28×12 and average velocity range from 0 to 8 m/s. In the same average velocity range for the cylindrical magnetic conductor the deviation from the average value of the signal is within range [-1%, 3.7%]. Furthermore, the volume coefficient of the rectangular magnetic core is  $K_T=0.66$ , which means that 2/3 of the magnetic materials used for round magnetic core are enough for the rectangular magnetic core. When the average fluid velocity is within the range 2-8m/s, then only insignificant changes of the signal (that do not exceed 0.06%) are detected for the magnetic conductor 24×16. Its volume coefficient is  $K_T=0.754$  which means that its demand for magnetic materials is by 1/4 lower comparing with the round magnetic core. It can be considered that the sensor is not sensitive to the profile of velocity in the above mentioned range. The interrelation between the electrode

signal and profile of fluid speed for rectangular magnetic conductor 28×12 may be decreased even further by increasing the width of electrode. The calculated deviation by using the rectangular electrodes 6×19 mm<sup>2</sup> was within the range [-0.28%, 0.17%] when the average velocity of fluid is in the limits 0-8m/s.

## Conclusions

1. Significantly higher sensitivity may be obtained in electromagnetic flow converter with the rectangular channel comparing with the cylindrical channel of the same cross-section area by using the same consumption of materials and energy. For example, the sensitivity of the flow converter with the cross-section area of 20cm<sup>2</sup> of the rectangular channel, which altitude is equal to the half of the base, is almost 1.5 times higher comparing with the cylindrical channel flow meter with the same cross-section area, when the same exciting coils are used.

2. It is recommended to use rectangular magnetic core for the flow converters with a rectangular channel, because these conductors ensure the smaller interrelation between the electrode signal and profile of fluid velocity as well as help to decrease the consumption of magnetic materials for their design.

## References

1. **Bevir M. K.** The theory of induced voltage electromagnetic flowmeter // J. Fluid Mech. - 1970. - Vol. 43, pt 3. - P.577-590.
2. **Padegimas R., Virbalis J. A.** Nuosėdų įtaka elektromagnetinio skysčio srauto matuoklio signalui // Elektronika ir elektrotechnika.- Kaunas: Technologija, 2002.- Nr.5(40).- P.59-64.
3. **Hemp J., Versteeg H.** Prediction of electromagnetic flowmeter characteristics // Journal Physics D: Appl. Phys., 19, 1986. – P. 1459-1476.

Presented for publication 2006 01 04

### **R. Padegimas, R. Vaikasas, J. A. Virbalis. Selection of the Magnetic Circuit Design for Electromagnetic Fluid Flow Converter with Rectangular Channel // Electronics and electrical engineering.- Kaunas: Technologija, 2006.– No. 3(67).– P. 41–46.**

Technological advantages are the main cause of popularity of electromagnetic fluid flow converters with cylindrical channel. But electrode signal of electromagnetic fluid flow converters with rectangular channel sensors has the significantly lower dependence on a velocity profile in the cross-section of the channel. Sensitivity of electromagnetic fluid flow converters with rectangular channel is higher. It is showed, that using the same magnetic field excitation coils with the same current, the electromagnetic flow converters with rectangular channel has more than 1.5 times sensitivity, than the electromagnetic flow transducers with cylindrical channel. The sensitivity increases, when ratio between high and base of channel rectangular cross-section decreases. There are better to use rectangular magnetic core in the electromagnetic flow converters with rectangular channel, directing the longer side of core cross-section perpendicularly to channel axis. The magnetic material, needed for core manufacturing, can be diminished till two times comparing with cylindrical core in this case, when the magnetomotive force is the same. By simulation, using finite element method, the magnetic cores of rectangular and circular shapes were compared in the electromagnetic flow converters with perpendicular channel. In the flow transducers with rectangular core shape the sensitivity dependence on velocity profile is significantly lower. Using core of perpendicular shape with longer side 2.33 times more than shorter side in the range of average velocity 0-8m/s the variation of sensitivity is not exceeded of limits [-0.28%, 0.31%]. Using core of perpendicular shape with longer side 1.66 times more than shorter side in the range of average velocity 2-8m/s the variation of sensitivity is not exceeded of limits  $\pm 0.03\%$ . By widening the electrodes, the variation of sensitivity can be diminished in the range of average velocity 0-8m/s. Ill.3, bibl.3 (in English; summaries in English, Russian and Lithuanian).

**P. Padegimas, P. Vайкасас, Ю. А. Вирбалис. Выбор конструкции магнитной цепи электромагнитных преобразователей расхода с прямоугольным каналом // Электроника и электротехника. - Каунас: Технология, 2006.–№ 3(67).– С. 41–46.**

Хотя сигнал электромагнитного преобразователя расхода с прямоугольным каналом меньше зависит от распределения скорости в поперечном сечении канала, из-за технологических соображений чаще применяется канал цилиндрической формы. Показано, что в электромагнитных преобразователях с прямоугольным сечением канала, применяя такой же индуктор с тем же током возбуждения можно достичь чувствительности 1,5 раза и более превышающую чувствительность электромагнитных преобразователей с цилиндрическим сечением. Чувствительность растёт с уменьшением высоты канала по сравнению с основанием. В преобразователях с прямоугольным сечением лучше применять магнитопровод прямоугольной формы, направляя большую сторону поперечно оси канала. В этом случае сохраняя ту же магнитодвижущую силу можно уменьшить потребность ферромагнитных материалов, необходимых для изготовления магнитопровода. Результаты моделирования, проведенного методом конечных элементов, показывают, что чувствительность преобразователей с прямоугольным магнитопроводом меньше зависит от профиля скорости преобразователей с цилиндрическим магнитопроводом. В преобразователе с прямоугольным сечением, длинная сторона которого 2,33 раза больше короткой в диапазоне средних в сечении скоростей потока 0-8м/с изменение чувствительности не выходит из пределов [-0,28%, 0,31%], а применяя прямоугольный магнитопровод, длинная сторона которого 1,66 раза короткой в диапазоне скоростей 2-8м/с изменение чувствительности не превышает  $\pm 0,03\%$ . Ил. 3, библи. 3 (на английском языке; рефераты на английском, русском и литовском яз.).

**R. Padegimas, R. Vaikasas, J. A. Virbalis. Stačiakampio kanalo elektromagnetinio skysčio srauto keitiklio magnetinės grandinės konstrukcijos parinkimas // Elektronika ir elektrotechnika.- Kaunas: Technologija, 2006.– Nr. 3(67).– P. 41–46.**

Nors stačiakampio kanalo profilio elektromagnetinių skysčio srauto keitiklių elektrodų signalas mažiau priklauso nuo skysčio greičio profilio kanalo skerspjūvyje, dėl technologinio paprastumo dažniausiai naudojami apvalaus profilio kanalai. Parodyta, kad naudojant tokias pat magnetinio lauko žadinimo rites, kuriose teka tokia pat srovė, srauto keitikliuose su stačiakampiu kanalu jautris išauga 1,5 karto ir daugiau, negu tokio pat skerspjūvio keitikliuose su apvaliu kanalu. Jautris didėja, mažėjant kanalo skerspjūvio aukščio ir pagrindo santykiui. Stačiakampio kanalo srauto keitikliuose geriau naudoti stačiakampės formos magnetolaidžius, nukreipiant ilgesniąją kraštinę statmenai kanalo ašiai. Šiuo atveju galima sumažinti magnetolaidžiui naudojamos magnetinės medžiagos kiekį iki dviejų kartų, esant tai pačiai magnetovarai. Modeliuojant baigtinių elementų metodu stačiakampiame kanale su strypo formos elektrodais buvo palyginti stačiakampės ir apvalios formos magnetolaidžiai. Srauto keitikliuose su stačiakampiu magnetolaidžiu jautris mažiau priklauso nuo skysčio greičio profilio negu su apvaliu magnetolaidžiu. Naudojant stačiakampį magnetolaidį, kurio ilgesnė kraštinė 2,33 karto didesnė už trumpesniąją, vidutinių skysčio greičių diapazone 0–8m/s jautrio pokytis neviršija ribų [-0,28%, 0,31%], o naudojant magnetolaidį, kurio ilgesnė kraštinė 1,66 karto didesnė už trumpesniąją skysčio greičių diapazone 2–8m/s jautrio pokytis neviršija  $\pm 0,03\%$ . Platinant elektrodus, galima sumažinti jautrio pokytį ir skysčio greičių diapazone 0–8m/s. Il. 3, bibl. 3 (anglų kalba; santraukos anglų, rusų ir lietuvių k.).