

## On DC Errors in Translinear Frequency Multipliers

Doru E. Tiliute

"Stefan cel Mare" University of Suceava

str.Universitatii nr.13, RO-720229 Suceava,e-mail: dtiliute@eed.usv.ro

### Introduction

Nowadays translinear circuits have a wide deployment in various integrated circuits like transconductance operational amplifiers [1,2], logarithmic amplifiers [3], current-mode feedback amplifiers, [4]. In the past few years a new class of applications was found for these circuits, namely the frequency multiplication. Frequency multiplication is an important function, mainly used in telecommunication and instrumentation systems. It is found in frequency synthesis, oscillators and modulation circuits. The conventional methods to achieve sinusoidal signals, whose frequency equals a multiple of a fundamental one, use the harmonic frequency filtering, the piecewise-linear voltage sawtooth operator or the fundamental-rejecting feedback. Despite this, the frequency multiplication has rarely been approached in literature as compared to other useful applications and only a few achievements have been reported [5,6]. In a previous paper [7] two new circuits topology, which perform frequency doubling and frequency tripling respectively, have been introduced. Both of them require a slight adjustment of the output current by means of additional current sources in order to reach high spectra purity and a low DC component. We will further discuss the frequency tripler circuit and the solution proposed to eliminate the DC component of the output current.

### The basic circuit

The basic circuit is outlined in Fig. 1.

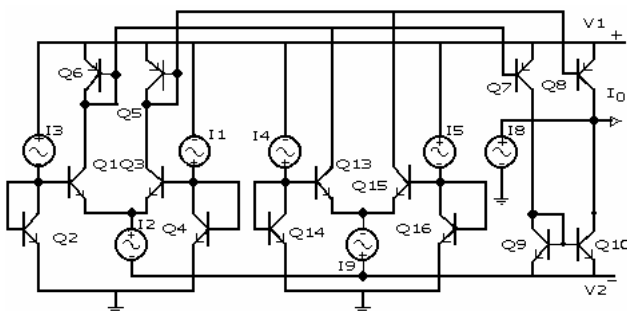

Fig. 1. Translinear frequency tripler

We will not further discuss the circuit functioning that has already been done in [7], we will only present the principle and the results.

The principle consists in the implementation of the trigonometric identity:

$$\sin 3\alpha = \sin \alpha + 2 \sin \alpha \cos 2\alpha \quad (1)$$

using translinear circuits. This is possible by means of a beta-insensitive Gilbert cell with two current sources, one of them having the fundamental frequency  $\omega$  ( $I1 / I3$ ) and the second with double frequency,  $2\omega$ , ( $I2 / I9$ ) and an algebraic circuit to perform elementary operation as addition and subtraction. In Fig. 1 the source of fundamental frequency is represented by two independent current sources with the same magnitude but in phase opposition.

Because each of the Gilbert cell outputs includes a component of double frequency, we choose to eliminate it by employing two identical Gilbert cells connected as shown in Fig. 2.

It was shown [7] that currents  $I1$  and  $I2$  from Fig. 2 could be expressed in the forms:

$$i_1 = I_{EB} - \frac{I_a^2}{I_B} \sin \omega t \cos 2\omega t, \quad (2)$$

$$i_2 = I_{EB} + \frac{I_a^2}{I_B} \sin \omega t \cos 2\omega t, \quad (3)$$

where  $I_a$  is the magnitude of variable components and  $I_{EB}$  and  $I_B$  are two bias currents.

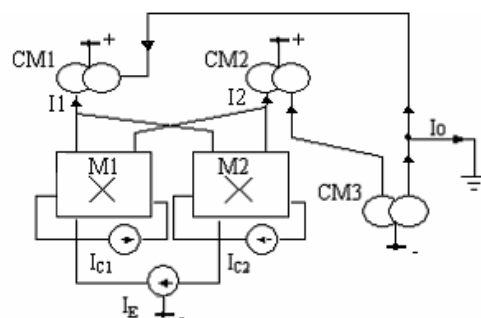

Fig. 2. Block scheme of circuit from Fig.1

Assuming that all current mirrors have unity gain, the output current is:

$$i_o = i_2 - i_1 = \frac{2I_a^2}{I_B} \sin \omega t \cos 2\omega t. \quad (4)$$

Comparing with equation (1) we notice that by simply adding the component with the fundamental frequency

$$\frac{I_a^2}{I_B} \sin \omega t, \quad (5)$$

we obtain frequency triplication:

$$i_o' = \frac{I_a^2}{I_B} \sin \omega t + \frac{2I_a^2}{I_B} \sin \omega t \cos 2\omega t = \frac{I_a^2}{I_B} \sin 3\omega t. \quad (6)$$

### Sources of errors

The two Gilbert multipliers M1 and M2 have identical structures and deploy bipolar transistors of the same type, so we are right in supposing that they will not produce any asymmetry in the output current.

Unlike this, it is easy to notice that the addition/subtraction circuits, built with current mirrors CM1 to CM3, are asymmetric and susceptible to produce unwanted components in the output current. Moreover, as it can be seen in Fig. 1, the current mirrors use transistors of different type, namely CM1 and CM2 use PNP transistors since CM3 uses NPN transistors. This is a new source for an additional asymmetry. In the basic circuit the current mirrors are regular ones, characterized by the gain  $k$ ,

$$k = \frac{\beta}{\beta + 2} < 1, \quad (7)$$

where  $\beta$  is the current gain of the bipolar transistors (all transistors are supposed to be identical with the same  $\beta$ ). This is an important factor which alters the circuit overall gain and the output current components.

For the circuit reproduced in Fig. 1 and the references of currents in Fig. 2, a new DC component occurs, the offset component, whose value is given by equation (8):

$$I_{OFF} = \frac{-\beta}{(\beta + 2)^2} I_{EB}. \quad (8)$$

At the same time the magnitude of variable component becomes smaller, with the exact value:

$$\frac{\beta(2\beta + 3)}{(\beta + 2)^2} \frac{I_a^2}{I_B}. \quad (9)$$

The role of the current source  $i_8$  is to nullify the DC component and to supply the suitable variable component for the frequency tripling.

SPICE simulations of the basic circuit yield the following values for the output components:  $I_{OFF} = -24\mu\text{A}$ ,  $i_o = 93\mu\text{A}$ ; the DC component is far different from the theoretical one which is  $-2.1\mu\text{A}$  since the variable

component with triple frequency is quite close to  $I_v = 81.2\mu\text{A}$ , value which was also theoretically determined. The cancellation of the DC component requires a DC current source connected to the output node of the circuit (included in  $I_8$  source in Fig. 1), with identical magnitude and opposite sign, which may be an extra complication of the circuit.

All simulations and computations were made with following values of source currents:  $I_{EB} = 0.22\text{mA}$ ,  $I_a = 0.1\text{mA}$ ,  $I_B = 0.12\text{mA}$

### Improved bipolar current mirror solution

A better way to improve the circuit functioning is the deployment of improved current mirrors instead of the regular ones. We must mention that this solution changes the translinear nature of the circuit converting it into a current-mode circuit. There is no problem with that since the translinear circuits represent a particular class of current-mode circuits, while the current-mode operation is the one that dictates the circuit special behavior. In bipolar technology there are such current mirrors, namely Wilson mirror, EF-augmented (EFA), cascode and Wildar (Widlar). In MOS technology there are also some topologies of MOS current-mirrors: simple, cascade and Wilson.

The diagram of bipolar Wilson mirror and EFA mirror are shown in Fig. 3. It is easy to show that both mirrors provide a gain very close to unity [8], or, in a more accurate analysis, equals to:

$$k = 1 - \frac{2}{\beta^2} \cong 1. \quad (10)$$

However, because the Wilson mirror exhibits larger output impedance due to the weak positive feedback effects, and thus being much closer to the ideal current source, we will further discuss this case only.

Therefore, with the value given in equation (10) we can expect a better response from the circuit.

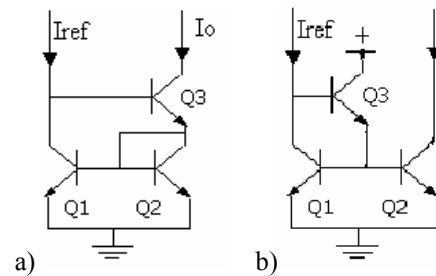

Fig. 3. a) The Wilson mirror and b) EF-augmented mirror

Indeed, renewing the errors computation with the new gain expression, the following values are found for the offset current and the variable component magnitude:

$$I_{OFF} = \frac{-2(\beta^2 - 2)}{\beta^4} I_{EB}. \quad (11)$$

$$\frac{2(\beta^2 - 1)(\beta^2 - 2)}{\beta^4} \frac{I_a^2}{I_B} \cong 1. \quad (12)$$

With (11) and (12) we can estimate the numeric values of the offset current and the variable component magnitude for the same currents of the sources as in the basic circuit example:  $I_{OFF}=0.043\mu A$ ,  $I_V=83.3\mu A$ .

The modified version of the tripler circuit is depicted in Fig. 4. Up to the basic circuit only three additional transistors have been included in order to achieve the Wilson mirrors.

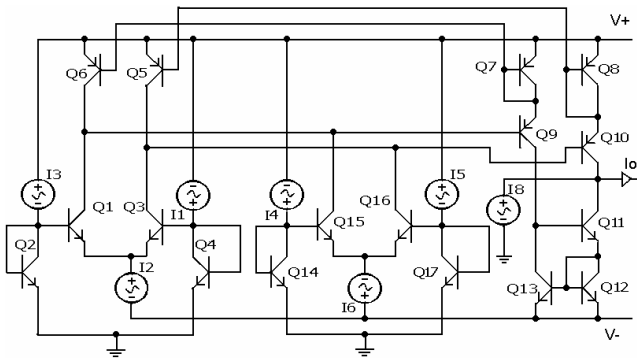

Fig. 4. Improved translinear frequency tripler

### MOSFET current mirror solution

MOSFET transistors have no power consumption on the gate input and this is a reason why we should take them into account, despite the worse frequency response comparing to the bipolar transistor.

The scheme of simple CMOS mirror is given in Fig. 5. For identical transistors the output current  $I_o$  equals the reference current  $I_{ref}$ .

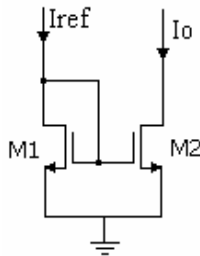

Fig. 5. Simple NMOS current mirror

The circuit topology remains the one depicted in Fig. 1, the only difference consisting in the replacement of bipolar current mirrors with simple MOS ones. Renewing the computation of the DC component in this case, we find that it should be zero.

### Simulated results

The simulations were made for both circuits, with bipolar Wilson mirrors and MOS simple mirrors, in the same conditions as the basic circuit. Fig. 6 displays the transient response of the circuit. The measured amplitude of the output signal is 82.2mA, result that matches well the value 83.3mA theoretically estimated. Further, the measured offset component is  $-0.58\mu A$ , which is over 10 times greater than the one estimated in ideal conditions, but over 40 times smaller than the offset of the basic

circuit. The ratio between the amplitude of the output current and offset current is far by favorable to the last circuit: 152.2 vs. 3.83.

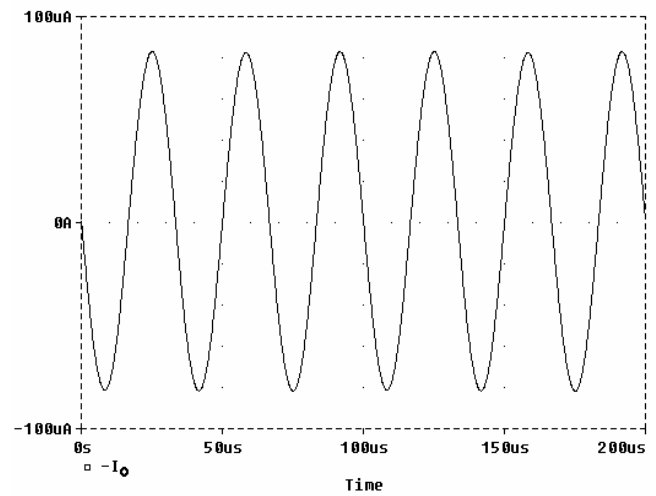

Fig. 6. Transient response of the tripler from Fig.4

Slight changes can be differentiated in the output current spectra, concerning the purity. Fig. 7 displays the magnitude of the main harmonic components; a ratio of 49.8dB has been measured between the third harmonic - the useful one - and the fifth harmonic that has the highest value among all unwanted components. The rejection of the fundamental is a bit smaller as compared to the basic circuit (52.6dB vs. 59.8dB).

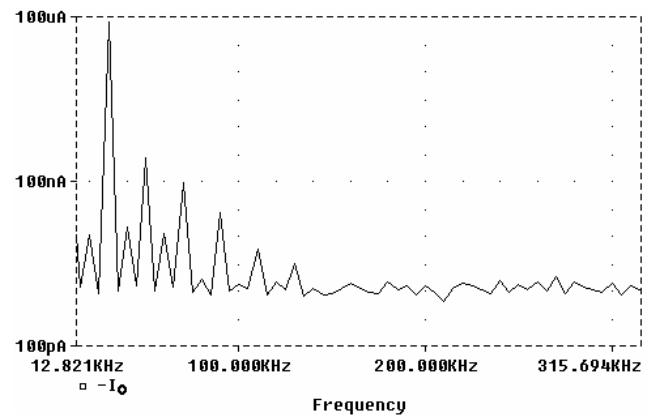

Fig. 7. Frequency spectra of output current (Wilson mirrors)

As for the circuit bandwidth it remains unchanged, as it can be seen in Fig. 8.

The employment of EFA current mirrors led to worse results regarding the offset current since the spectra and the frequency response remained practically unchanged. During simulations, each EFA mirror has a resistor of 300 ohms in the emitters of Q1-Q2 transistors.

As for the MOS current mirrors the simulations confirmed the better behavior of the circuit regarding the DC component. Unfortunately, in this case, the rejection of the fundamental and fifth harmonic is lower compared with all the bipolar implementations. On the other hand, the highest harmonics are practically eliminated, as can be seen in Fig. 9.

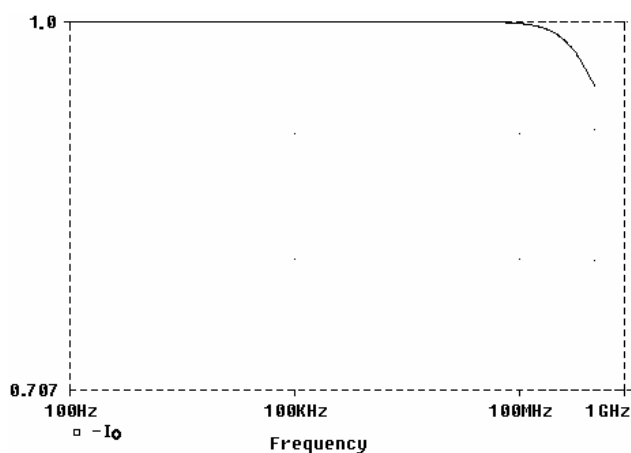

Fig. 8. Frequency response of the tripler circuit from Fig.4

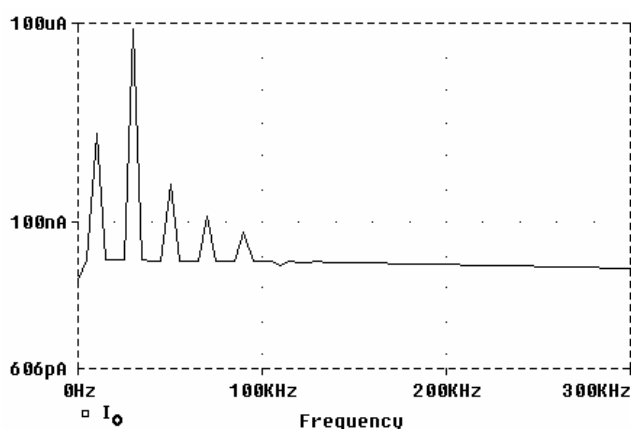

Fig. 9. Frequency spectra of output current (MOS mirrors)

All these results are presented in table 1, alongside the basic circuit ones, in order to facilitate the comparison.

Table 1. Comparative results

	Regular	EFA	Wilson	MOS
Offset	24 $\mu$ A	11 $\mu$ A	0.043 $\mu$ A	18pA
Iv	93 $\mu$ A	83.4 $\mu$ A	82.2 $\mu$ A	82.4 $\mu$ A

## Conclusions

We tried to show that a basic translinear circuit that has the property to achieve frequency tripling without the need of resonant circuits could be optimized from the viewpoint of the DC component magnitude in its response. The analysis of the circuit topology led to the possible source of errors. The adoption of an improved solution for the arithmetic circuit, by replacing regular current mirrors with Wilson current-mirrors or MOS current mirrors, led practically to the cancellation of the offset current. Depending on application, pondering the advantages and the drawbacks of each solution, we can adopt the better one. Both in Wilson and MOS current mirror solutions, due to the very low level of the offset current, no external trimming circuits are required.

## References

- \*\*\*\* Analog Devices, AD844 Monolithic OpAmp Datasheet.
- \*\*\*\* Analog Devices, OPA660 Operational Transconductance Amplifier and Buffer Datasheet.
- \*\*\*\* Analog Devices, ADL5306 Low Cost Logarithmic Converter Datasheet.
- \*\*\*\* Intersil, EL2180, EL2280, EL 2480 Current-Mode Feedback Amplifier Datasheet.
- Muhammad Taher Abuelma'atti.** A translinear circuit for sinusoidal frequency multiplication. International Journal of Electronics, Taylor & Francis (publishers), Vol. 86, No. 1 January 1999, P. 35 – 41.
- T.Y. Lin and A. J. Pane.** Translinear sinusoidal frequency tripler. Electronics Letters, 9th. May 2002, Vol.38 No.10. P. 441 – 442.
- Doru E. Tiliute.** Current-mode Sinusoidal Wave Multipliers, IEEE-ISSCS 2005 Proc. Vol.2. P. 421 – 424.
- Barrie Gilbert.** Bipolar Current Mirrors, Analogue IC Design: the current-mode approach, C. Toumazou, F.J. Lidgey and D.G. Haigh (Eds.), Peter Pelegrinus 1990.

Presented 2006 01 16

**Doru E. Tiliute. On DC Errors in Translinear Frequency Multipliers // Electronics and Electrical Engineering. – Kaunas: Technologija, 2006. – No. 2 (66). – P. 41–44.**

In this paper we discuss some circuit solution intended to eliminate or to reduce the DC errors occurring in some new high bandwidth translinear frequency multipliers. Errors arise as a result of the circuit's topology or/and of the non-ideal devices behavior. All the proposed solutions refer to a particular frequency tripler circuit and leads to significant reduction the output-offset current of a to values very close to zero. Ill. 9, bibl. 8 (in English; Summaries in English, Russian, Lithuanian).

**Дору Е. Тилиуте. Погрешности постоянного тока в транслинейарных множителях частот // Электроника и электротехника. – Каунас: Технология, 2006. – № 2 (66). – P. 41–44.**

Обсуждаются несколько схемотехнических решений, предназначенных для устранения или уменьшения погрешностей постоянного тока в нескольких новоразработанных транслинейарных множителях частот. Эти погрешности возникают в результате специфической топологии электронной схемы или/и неидеального поведения электронных устройств. Все предложенные и обсужденные решения относятся к специфической электронной схеме частотного триплера и приводят к существенному уменьшению постоянной составляющей выходного тока к значениям очень близким к нулю. Ил. 9, библ. 8 (на английском языке; рефераты на английском, русском и литовском яз.).

**Doru E. Tiliute. Nuolatinės srovės paklaidos translineariniuose dažnių daugintuvuose // Elektronika ir elektrotechnika. – Kaunas: Technologija, 2006. – Nr. 2 (66). – P. 41–44.**

Aptariami kai kurie elektrinių grandinių variantai, skirti eliminuoti arba sumažinti nuolatinės srovės paklaidoms, atsirandančioms kai kuriuose naujuose plačiajuosčiuose translineariniuose dažnių daugintuvuose. Paklaidų atsiranda dėl grandyno topologijos arba (ir) dėl neidealaus įtaisų veikimo. Visi pasiūlytieji sprendimai tinkami konkrečiam dažnių trigubinančiam grandynui ir leidžia gerokai sumažinti išėjimo nulio poslinkio srovę iki verčių, artimų nuliui. Il. 9, bibl. 8 (anglų kalba; santraukos anglų, rusų ir lietuvių k.).

DOI: 10.5755/j02.eie.10593