

Case Shielding Efficiency, High Frequency Technology

A. Ruško, V. Novikovs, G. Balodis

*Faculty of electronics and telecommunications, Riga Technical University,
 12 Azenes str., LV-1048 Riga, Latvia, phone: + 371 6 7089292; e-mail: andris.rusko@rtu.lv*

Introduction

The aim of this paper is to present the comparison of different EM (EM) shielding case vent shapes and estimate efficiency on EM shielding.

The stability of electronic devices in wide range of frequency and in different conditions is dependent not only from electrical circuit layout, but also from technological and constructive solution [1,3]. Of course, it is dependent on EM situation around defined device that is featured by the parameters of EM compatibility [2]. From this point of view, the integral part of the effective functioning device is the EM shield. This shield activity is possible in completely wide frequency range of used EM processes. The successful work of electronic devices is possible to describe with multiport matrixes [4,5,6]. In high and super high range of frequencies, as well taking into account the wave processes, is easy to use scattering $\|S\|$ and transmission $\|T\|$ matrixes [6].

EM shielding purpose:

1. Reduction of conducted emissions;
2. Reduction of inducted emissions;
3. Reduction of bridge connections;
4. Reduction of radiated emissions.

As example (see Fig. 1), scattering matrix $\|S1\|$ describes shielded device, which forms the scattering matrix of the device itself $\|SI\|$ and shield scattering matrix $\|SE\|$.

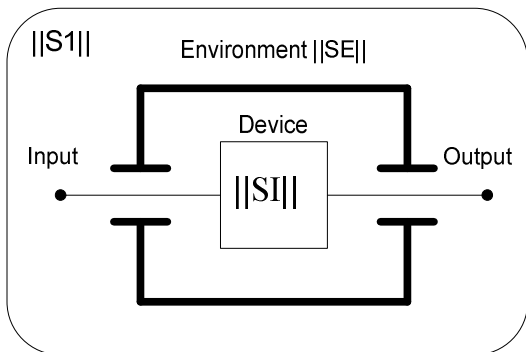

Fig. 1. Description of shielded device

It is possible to interpret shielding as serial or parallel connection of shield to unshielded device, see Fig. 2 and 3.

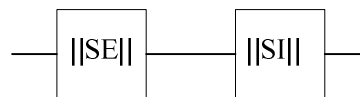

Fig. 2. Serial shielding connection

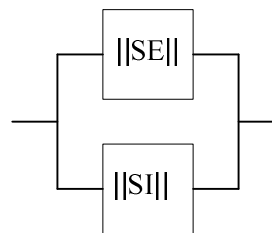

Fig. 3. Parallel shielding connection

Physically shielding process describes parallel shielding structure. Alternatively, circuit descriptive methods for shielding structures are used, where voltage or current sources are presented, some like static shields, and some – with EM shield components: intensity of electrical shield E, intensity of magnetic shield H and power flux or Umov (Poynting) vector Π . The quadruple scattering matrix $\|SI\|$ characterize the device working parameters as:

$$\langle SI \rangle = \begin{pmatrix} S_{11} & S_{12} \\ S_{21} & S_{22} \end{pmatrix}. \tag{1}$$

Scattering matrix $\|SE\|$ characterize the EM shielding:

$$\langle SE \rangle = \begin{pmatrix} S_{11} & S_{12} \\ S_{21} & S_{22} \end{pmatrix}. \tag{2}$$

An equation (1, 2) includes different constructive and electric shield parameter impact on shielding quality parameters. Scattering matrix-combining operation describes shielded device scattering matrix $\|S1\|$ as follows:

$$\langle S1 \rangle = \langle SE \rangle \times \langle SS \rangle \times \langle SI \rangle, \tag{3}$$

where SS matrix is combining matrix with values:

$$\langle SS \rangle = \begin{pmatrix} 0 & 1 \\ 1 & 0 \end{pmatrix}. \quad (4)$$

When all design and electric equivalent data for S matrix are described, it can be written as $\langle S1 \rangle$:

$$\langle S1 \rangle = \begin{pmatrix} S11 & S12 & S13 & S14 & S15 \\ S21 & S22 & S23 & S24 & S25 \\ S31 & S32 & S33 & S34 & S35 \\ S41 & S42 & S43 & S44 & S45 \\ S51 & S52 & S53 & S54 & S55 \end{pmatrix}. \quad (5)$$

From point of view of wave matrixes, input or output connection in series or parallel describes electric coupling for parallel structure E and magnetic coupling for series structure H.

Analysis

It is possible to perform modelling of E field connection with environment with two decomposition elements: parallel T shaped branch with matched attenuation, for example, with 10 dB attenuator. Parallel T branch are described with two parameters: wave impedance ratio between 2 and 1 input $p_1 = W1/W2$ and wave impedance ratio between 3 and 1 input $p_2 = W1/W3$, see Fig. 4. If $p = 0.5 \cdot (1 + p_1 + p_2)$ then scattering matrix for this element describes as follows:

$$\|S\| = \frac{1}{p} \begin{pmatrix} 1-p & \sqrt{p_1} & \sqrt{p_2} \\ \sqrt{p_1} & p_1-p & \sqrt{p_1 p_2} \\ \sqrt{p_2} & \sqrt{p_1 p_2} & p_2-p \end{pmatrix}. \quad (6)$$

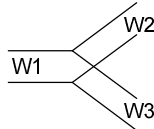

Fig. 4. Parallel T shaped branch

Matching attenuator Z with attenuation of $a=10$ dB scattering matrix, see Fig. 5.

$$\|S\| = \begin{pmatrix} 0 & a \\ a & 0 \end{pmatrix}. \quad (7)$$



Fig. 5. Matching attenuator

Series T shaped branch are described with two parameters: wave impedance ratio between 1 and 2 input $p_1 = W1/W2$ and wave impedance ratio between 2 and 3 input $p_2 = W2/W3$, see Fig. 5. If $p = 0.5 \cdot (1 + p_1 + p_2)$

then scattering matrix for this element is described as follows:

$$\|S\| = \frac{1}{p} \begin{pmatrix} 1-p & \sqrt{p_1} & \sqrt{p_2} \\ \sqrt{p_1} & p-p_1 & -\sqrt{p_1 p_2} \\ \sqrt{p_2} & -\sqrt{p_1 p_2} & p-p_2 \end{pmatrix}. \quad (8)$$

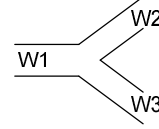

Fig. 6. Series T shaped branch

By making many elements branched structure from scattering $\|S\|$ matrixes for shielding and shielded device equivalent model can be estimated shielding and shielded structures mutual influence and shielding efficiency. If shielding theoretical model describes voltages and currents, then it is efficiently to describe concentrated (R, L, C) parameters with similar scattering matrix elements. However, if it is used description of electrical, magnetic or EM field, then scattering parameters (T-type, E-type or H-type) or similar waveguide element models forms like circuits. Combining modelling element scattering matrixes models, respectively. These parameters was described with scattering matrix elements, and universal utility for wide frequency spectrum band and varied shielding model analysis is formed.

For example, effect of leakage of device parasitic capacity appears when device is connected to shielding with electrical field, slightly improving shielding efficiency, see Fig. 7.

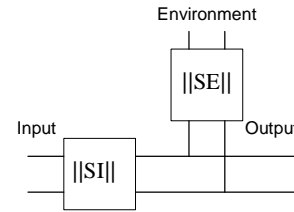

Fig. 7. Parallel structure

Other vice connection of series shielding to device provides shunting of device parasitic inductance or magnetic field by forming series magnetic link and providing improvement of shielding efficiency, see Fig. 8.

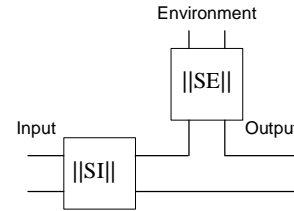

Fig. 8. Series structure

In any case, shielded device has differed in parameters from equivalent unshielded, for example with transmission coefficient. By using scattering $\|S1\|$ matrix one can describe device with shielding and environmental influence. Two examples have been calculated in MatLab.

First of all let's determine reduction for electrical and magnetic field to environment, see Fig. 9 and 10.

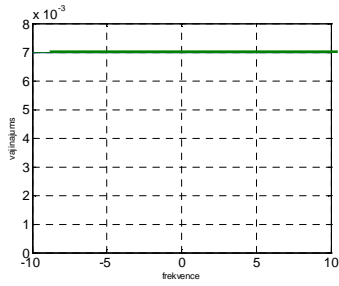

Fig. 9. Transmission coefficient to environment

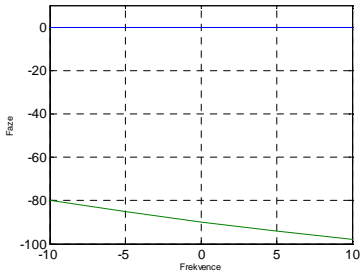

Fig. 10. Transmission coefficients with environment phase

Next determine reduction for electrical and magnetic field for shielded device, see Fig. 11 and 12.

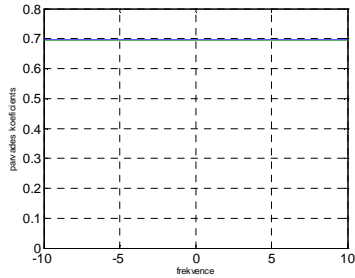

Fig. 11. Transmission coefficients for shielded device

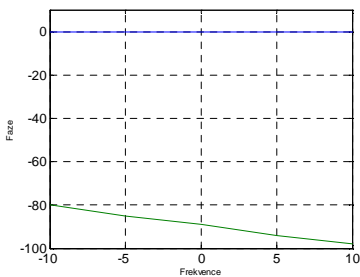

Fig. 12. Transmission coefficients for shielded device phase

System model

Ansoft HFSS software [7,8] is based on finite element method calculation, and was used instead of MatLab for faster calculations related to system model. Nearly real physical, customized waveguide model was build representing shielded device, see Fig.13.

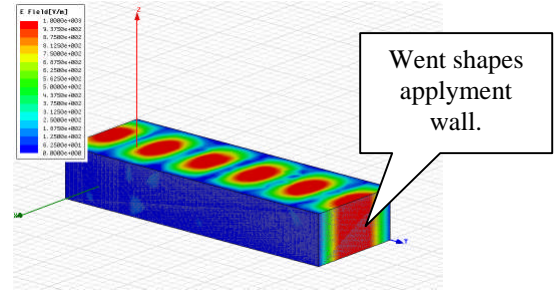

Fig. 13. Customized waveguide

Model materials: walls – aluminum, opened vents, environment – air. For better comparison of shielding properties one mode of E_{10} was used. Custom waveguide was build, with dimentions $a=50[\text{mm}] \times b=25[\text{mm}] \times l=150[\text{mm}]$, and wall thickness of $1[\text{mm}]$, providing frequency range for desired one mode wave from 3 to 6 GHz.

For better reference to practical designs, ventilation holes and wire terminals, standart circle vent shape of $\varnothing 5[\text{mm}]$ was taken, see Fig. 14. All other shapes was calculated to get the same surface size.

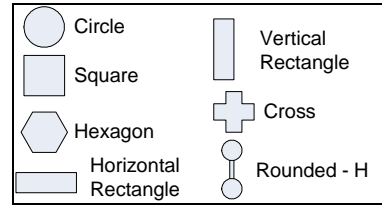

Fig. 14. selected waveguide vent shapes

Modelleing results

Modeling results of transmission coefficient, see Fig. 15.

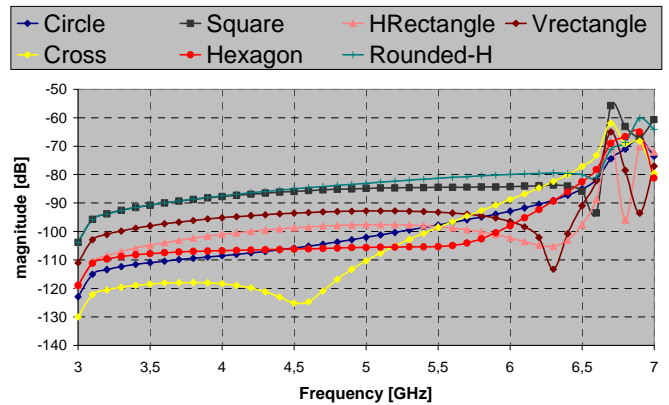

Fig. 15. Modelled transmission coefficients

Conclusions

1. The efficiency of shielding can be defined by calculating voltage or current transmission ratio for circuits with lumped elements, by using the Kirchhoff and Ohm law.
2. The link with an environment most often value with the help of Maxwell EM field theory methods as well as description with scattering S matrix.

3. Recalculating the voltage, current or EM field transmission ratio and using the definitions of scattering matrix for these coefficients, we get unified calculation method for modelling the shield efficiency for shielded devices.

4. If defining vents for case cooling, optical decoupling, construction weight reduction and shielding simultaneously, considered vent shapes – hexagon or cross are preferable.

Acknowledgements

Research financially supported by Latvia Science Council grant No. 05-1638.

This work has been partly supported by European Social Fund financing the project „Support for the development of doctoral studies at Riga Technical University” developed within the Latvia National Programme „Support for doctoral study programmes and post-doctoral research”.

References

1. **Balodis G.** Sazarotu ķēžu aprēķināšana. Lekciju konspekts. – Rīga, RTU. – 1992. – 311 p.
2. **Balodis G.** Ekrānu konstrukcijas. Lekciju konspekts. – Rīga, RTU. – 1990. – 32 l p.
3. **Балодис Г.** Многополюсники СВЧ. Конспект лекций. – Рига, РТУ. – 1991. – 57 с.
4. **Gupta K., Ramesh G., Rakesh C.** CAD of Microwave Circuits. Kanpur // Artech House. – 1981. – 432 p.
5. **Altman J.** Microwave Circuits. – NewYork: van Nostrand Company, 1964. – 488 p.
6. **Фелдштейн А., Явич П., Смирнов В.** Справочник по элементам волноводной техники. – Москва: Сов. радио, 1967. – 652 с.
7. **Ansoft HFSS-10** Software User Guide. – V.10-1. – 2005.
8. **CST Microwave Studio** User Guide. – V. 4.3. – 2004.

Received 2008 05 22

A. Ruško, V. Novikovs, G. Balodis. Case Shielding Efficiency, High Frequency Technology // Electronics and Electrical Engineering. – Kaunas: Technologija, 2009. – No. 1(89). – P. 79–82.

We have presented the comparison of different electromagnetic (EM) shielding case vent shapes (different shape, but same surface) and estimate EM shielding efficiency for one mode E wave. EM shield is the integral part of the effective functioning devices. By changing type of the shape vent, it is possible to minimize EM impact. It is offered to value the shielding efficiency, by using scattering S matrix in analysis. Ill. 15, bibl. 8 (summaries in English, Russian and Lithuanian).

А. Рушко, В. Новиков, Г. Балодис. Эффективность экранирования корпусов при высоких частотах // Электроника и электротехника. – Каунас: Технологія, 2009. – № 1(89). – P. 79–82.

Проведено сравнение параметров отверстий (разной формы, но одинаковой по площади) в электромагнитически экранирующих корпусах и определена эффективность ЭМ экранирования для одного типа электрической E волны. ЭМ экранирование является составной частью функционирующего устройства. Изменяя формы отверстий можно достигнуть уменьшение ЭМ воздействия. Предложен метод оценки эффективности экранирования, применяя для анализа дисперсионную S матрицу. Ил. 15, библи. 8 (резюме на английском, русском и литовском яз.).

A. Ruško, V. Novikovs, G. Balodis. Korpuso ekranavimo efektyvumas esant aukštiesiems dažniam // Elektronika ir elektrotechnika. – Kaunas: Technologija, 2009. – Nr. 1(89). – P. 79–82.

Pateiktas elektromagnetikai (EM) ekranuojančių korpusų vėdinimo angų formų (skirtinga forma, tačiau tame pačiame paviršiuje) palyginimas ir įvertintas vienos E bangos modos EM ekranavimo efektyvumas. EM ekranas yra integrinė efektyviai veikiančių įtaisų dalis. Keičiant vėdinimo angos formą galima minimizuoti EM laukų poveikį aparatūrai. Pasiūlyta ekranavimo efektyvumą analizuoti naudojant S parametrų matricas. Il. 15, bibl. 8 (anglų kalba; santraukos anglų, rusų ir lietuvių k.).

DOI: 10.5755/j02.eie.10580