

## **Material Saving Constructional Solution for Lamps Made of Reinforced Polyester, in Use at the Lower Temperatures of the Baltic States**

**F. Pracht**

*Falkenweg 5, 35232 Dautphetal-Buchenau, Germany, e-mail: friedhelm.pracht@pracht-lichttechnik.de*

**A. Ilgevičius**

*Kviečių 2C-9, 08436 Vilnius, Lithuania, e-mail: audrius.ilgevicius@varikonta.lt*

### **Introduction**

Experience shows that the yearly average of the environmental temperatures in the Baltic States is lower than in the Western European or South European neighbouring states. Based on the cost pressure which exists nowadays, it shall therefore be discussed, how an increase of the efficiency of the luminous flux of the lamps can be achieved, on a material saving and cost-saving base and with responsibility for the product.

The object of the research was a luminaire, particularly a closed luminaire with at least one fluorescent lamp with a socket on the end side, a transparent diffuser which encloses the complete fluorescent lamp with a distance, and which is supported in the end parts, as well as a heat accumulation tube which encloses said fluorescent lamp, and is made of a translucent material, principally polycarbonate [1].

Luminaires [2] of this kind are common knowledge and are used in the field quite often, outdoors, indoors and also in environments with very low temperatures. It is also common knowledge, that, depending on the environmental conditions, these luminaires have a noticeable decrease of the luminous flux, especially at very low temperatures. This is also applicable for luminaires, which are used outdoors or in spaces which are in immediate connection to the outside, e.g. railway stations, parking garages and suchlike [3], with possible variations of temperatures, dependent on the time of the year, of -20°C up to +30°C.

For low environmental temperatures a luminaire [4] has already been developed, which is preferably used in cold stores, and in which luminaire the fluorescent lamp is enclosed by several concentric tubes which form air layers. Between these adjacent air layers such a narrow air gap is formed that almost no gas flow, which influences the thermal resistance, can take place between the adjacent air layers. It is indeed profitable to use this luminaire con-

struction in cases of special application, e.g. as a luminaire for cold stores, but this is connected with corresponding efforts and comparatively high production costs.

### **What has to be achieved?**

The assignment of the research project was, to design a particularly low-priced and cost-efficient luminaire, and nevertheless at least still strongly reduce the undesirable loss of the luminous flux, in order to obtain an alternative solution for general outdoor lighting and for lighting in open buildings.

A solution to this assignment has been found, by shaping the protecting tube on both ends over the adapter bushings, which function as heat accumulator, and which hold the heat accumulation tube, and which internal space is connected, through the end parts, with a limited internal space of the diffuser, of the heat accumulation tube and of the end parts, and as such facilitate the required air exchange between these parts.

Whereas at normal and also at high summer temperatures, this construction does not result in an adverse effect of the performance of the luminaire, the adapter bushings that function as a heat accumulator, combined with the heat accumulation tube, produce an essential improvement of the efficiency of the luminaire at low outside temperatures, which can reach -20°C, for example in the Alp region and in Lithuania. This means a quite definite reduction of the loss of luminous flux, which would otherwise be inevitable.

An advantage of this is, that, to achieve these favourable results, the required efforts are downright marginal and the required parts, namely heat accumulation tube and adapter bushings, can be adapted trouble-free to existing luminaires, which means that conventional luminaires can be retrofitted without any problems.

Usually the adapter bushings extend from the end part till approx. the end of the electrode [5] of the fluorescent lamp. On the one hand this avoids any kind of disturbing light loss, which would result if the fluorescent lamp were covered by the adapter bushings, whereas on the other hand, the effectiveness of the heat accumulation of the adapter bushings is concentrated precisely on the functionally important electrode of the fluorescent tube. These adapter bushings are preferably made of metal, particularly of aluminium [6], which is easy to machine, or made of brass, but the material thickness has to be such, that a sufficient heat accumulation effect is achieved. This can already be achieved with a material thickness of approx. 1 to 2 mm. The heat accumulation tube can be made of glass, but more often the use of transparent polycarbonate is preferred. When using polycarbonate, precautions should be taken by using electronic devices, for example a security starter, to avoid, in case of a short circuit of the lamps, such temperature increases which would endanger the heat accumulation tube.

The adapter bushings can be made as bushings with longitudinal slots with radial springs, in which for example distance elements can be made through radial slots, which hold the heat accumulation tube. Usually the adapter bushings are made as cylindrical bushings, with spring shackles formed on the free end, which protrudes over the outside of the bushing and form a support for the heat accumulation tube. To ensure that the position between the adapter bushings and the heat accumulation tube is fixed, and to prevent the adapter bushings from sliding into the heat accumulation tube, especially when mounting the luminaires vertically, catches are formed on the adapter bushings, which define the depth of penetration of the heat accumulation tube into the adapter bushing. The drawing shows the fundamental parts of the newly constructed luminaire in a perspective partial presentation of each part.

Shown are an end part (1) of a luminaire, an adapter bushing (8) shaped in this end part (1) for support, a section of a heat accumulation tube (7) as well as a section of a diffuser (6).

End part (1) has a centric opening (2) for the fluorescent lamp. Evenly spaced out on the perimeter of this opening (2) are three lugs (3) moulded to the end part (1), which serve the purpose of supporting the brake springs (4). These brake springs fasten onto the lamp, once it is inserted, with a certain degree of prestress, and in this way secure the lamp, so that it cannot easily slide out of the luminaire and break to pieces, when changing the lamps for example.

Adjusted to the outside contour of the end part (1), over the whole outline of the end part (1) runs a retaining groove (5), with which the diffuser (6), which is formed accordingly, engages with when mounted. The cylindrical adapter bushings (8), mostly made of aluminium, have moulded-on spring shackles (9) on the end side, which is opposite from the end part (1), and which protrude from the outside perimeter of the adapter bushings (8). These can be easily formed by making the necessary slots in the bushings (8) and then forming the springs out of the obtained flaps. The spring shackles (9) form the bearing area for the heat accumulation tube (7), whereas the different diameters of the adapter bushing (8) and the heat accumu-

lation tube (7) define the annular gap which is intended for the air circulation.

Towards the end part (1), the adapter bushing (8) has slots (11), and on the side of the slots, which is opposite to the end part, catches (10) have been formed by bending the material, and these catches protrude radially outwards. These catches (10) define the maximum depth of penetration of the adapter bushings (8) into the heat accumulation tube (7).

The position and dimension of the slots is such, that when mounting the luminaire, the brake springs (4) protrude through the slots and in that way can fulfil their function unhindered. Furthermore these apertures also define the position of the adapter bushings (8), which are being held by the lugs (3).

When the luminaire is assembled, the diffuser (6) encloses the heat accumulation tube (7), but the annular gap between the fluorescent lamp and the heat accumulation tube (7), based on the difference in diameter between the adapter bushing (8) and the heat accumulation tube (7), is in such connection to the space between the heat accumulation tube (7) and the diffuser (6), that an air exchange can take place, which particularly protects the used synthetic materials by dissipating the heat.

Independent of which cross-sectional form of the diffuser is chosen (6), it is possible to use a diffuser of such cross-sectional form and, if necessary, with reflecting surfaces, as meets the respective requirements. In that way a multifunctional, cost-saving and energy-saving luminaire is available, which, despite its simple mounting, minimises the bothersome loss of luminous flux, also at low outside temperatures.

### Points of optimisation

1. A luminaire shall be developed, especially a closed luminaire with at least one fluorescent lamp with a socket on the end side, and with a transparent diffuser, which encloses the fluorescent lamp and is supported in the end parts, as well as a protecting tube which encloses the fluorescent lamp, and which is made of a translucent material. The heat accumulation tube is shaped on both ends over the adapter bushings (8), which function as heat accumulator, and which hold the heat accumulation tube, and which internal space of the end side is in such connection to a limited internal space of the diffuser (6), of the heat accumulation tube (7) and of the end parts, as to allow an air exchange.
2. The adapter bushings (8) extend from the end part (1) almost till the end of the electrode of the fluorescent lamp.
3. The adapter bushings (8) are made of metal, particularly aluminium, or made of brass.
4. The material thickness of the adapter bushings (8) is approx. 1 to 2 mm.
5. The adapter bushings (8) should be connected with the heat accumulation tube (7) in an elastic squeeze, and should at least have catches (10) which define the depth of penetration of the adapter bushing (8) into the heat accumulation tube (7).

6. The adapter bushings (8) should be made as bushings with longitudinal slots and radial springiness.
7. The adapter bushings (8) should be cylindrical bushings with moulded-on spring shackles (9), which shackles are on the end side, opposite of the end part (1), and which protrude from the outside perimeter of the adapter bushing.
8. The heat accumulation tube (7) should be axially manoeuvrable and held by an annular gap on the adapter bushings (8).
9. On the end parts (1) is an opening where a fluorescent lamp can pass through, and evenly spaced on the perimeter of this opening (2) should be three lugs (3) moulded to the end parts, which span towards the inside of the luminaire, and which serve the purpose of supporting the brake springs (4), so that the adapter bushings are positioned between these slugs and have slots (11) for the penetration of the brake springs.
10. The heat accumulation tube (7) is made of polycarbonate or glass.
11. The cross-sectional form of the diffuser (6), which is either held by its form in the end parts, or which is glued on permanently, is independent of the cross-sectional form of the heat accumulation tube, and therefore the cross-section of the diffuser can be chosen freely, and can be different from the cross-section of the heat accumulation tube.

The photo shows a luminaire with an open section, with at least one fluorescent lamp, with a socket on the end side, a diffuser which encloses the fluorescent lamp and which is held in the end parts, as well as a protecting tube, made of a translucent material. The protecting tube is shaped on both ends over the adapter bushings, which function as heat accumulator, and which hold the heat accumulation tube, and which internal space is connected, through the end parts, with a limited internal space of the diffuser, of the heat accumulation tube and of the end parts, and as such facilitate an air exchange. Very recognisable is the adapter bushing with the heat accumulation tube in the diffuser. The cross-section of the diffuser can be shaped freely.

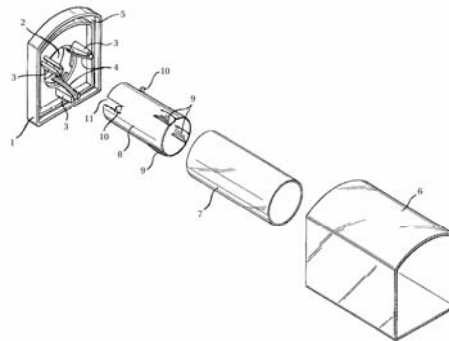

**Fig. 1.** Luminaire housing with lamp cover and heat accumulation tube

Figure 1 shows a prototype with a section of visible installed heat accumulation tube with adapter bushing of construction variant in Figure 2.

The results of the research are listed in the following table and in the graph, Figure 3.

The lab measurements show a clear gain of luminous flux when using the researched system.



**Fig. 2.** Diffuser with heat accumulation tube, adapter and end part: 1 – End part; 2 – Opening for a fluorescent lamp; 3 – Slug; 4 – Brake spring; 5 – Retaining groove; 6 – Diffuser; 7 – Heat accumulation tube; 8 – Adapter bushings; 9 – Spring shackle; 10 – Catch; 11 – Slot

**Table.** Intensity of light E depending on the environmental temperatures Tu

Luminaire type:	PPR	PPR	PPR	PPR	PPR	PPR
Diffuser: (Abbreviations see Figure 3)	LS- HIR WST 38mm	LS PC 50m m	VK R OPA K	VK R IG	VKR IG WST	VKR IG WST
Nominal power rating of lamp:	1 x 58W	1 x 58W	1 x 58W	1 x 58W	1 x 58W	1 x 58W
Ballast:	VVG	EV G	EV G	VV G	EVG	VVG
Tu [°C]	E [lx]	E [lx]	E [lx]	E [lx]	E [lx]	E [lx]
-40	126	19	14	21	44	97
-30	259	37	27	43	107	194
-20	352	77	53	80	299	324
-10	363	183	121	194	333	354
0	347	357	278	345	340	328
10	325	388	326	365	328	300
20	306	385	332	359	293	283
25	293	380	329	349	278	275
30	274	350	313	330	263	264
40	260	324	283	308	238	242

### Conclusion

Lab measurements have shown that the built-in heat accumulation tube brings substantial advantages.

The aim, to achieve a cost-efficient, technically matured solution to increase the efficiency, and this with preferably low costs, has been achieved optimally.

### References

1. Menges G. Haberstroh E. Michaeli W. und Schmachtenberg E. Werkstoffkunde Kunststoffe. Carl Hanser Verlag, München und Wien. 2002. – 5. völlig überarbeitete Aufl. – S. 14.

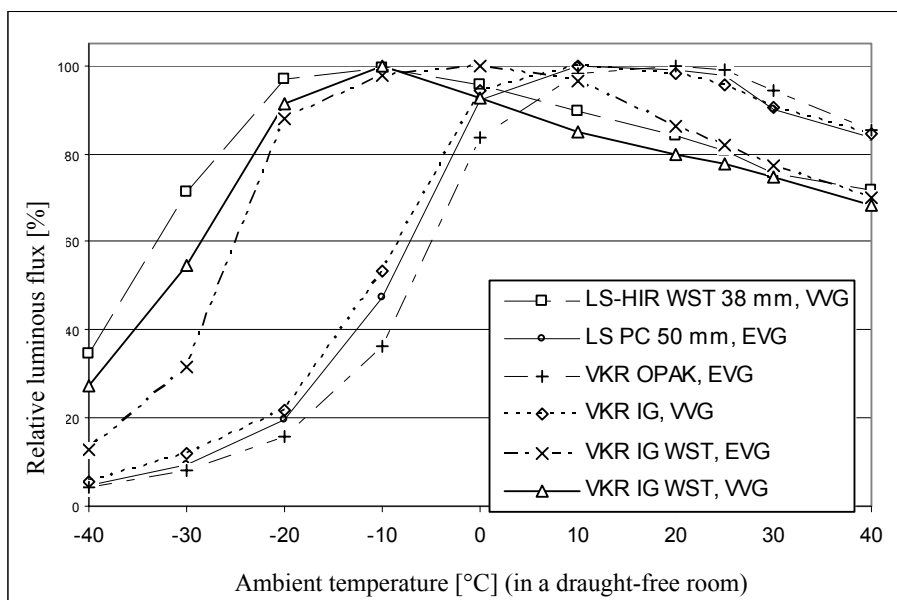

**Fig. 3.** Relative luminous flux as a function of ambient temperature and diffuser. Abbreviations for the lamp covers: HIR: High-gloss internal reflector, IG: Inside ribbing, clear, LS: Lamp protection tube, OPAK: Slightly opalescent, PC: Polycarbonate, VKR: Square tube, WST: Heat accumulation tube

- Schwarz O., Ebeling F.-W. und Furth B. Kunststoffverarbeitung. Vogel Buchverlag. Würzburg. 2002. 9. überarbeitete Aufl. – S. 163
- Ris H. R. Beleuchtungstechnik für Praktiker. Grundlagen, Lampen, Leuchten, Planung, Messung. VDE Verlag.– Berlin und Offenbach. AZ Verlag. Aarau. 2003.– 3. Aufl. –S. 327-345.
- Patentdruckschrift DE 40 12 588 C2, Europäisches Patentamt München.
- Halbritter H.-P. und Sattler J. Leuchten Erläuterungen zu DIN VDE 0711/ EN 60 598 und VDE 0710. VDE-Verlag. Berlin und Offenbach. – 2001. 4. vollständig überarbeitete Aufl. – S. 137.
- Fischer U., Näher F., Röhrer W., Heinzler M., Oesterle S., Stephan A., Kilgus R., Paetzold H. und Winkow R. Tabellenbuch. Pateikta spaudai 2005 10 16

**F. Pracht, A. Ilgevičius. Material Saving Constructional Solution for Lamps Made of Reinforced Polyester, in Use at the Lower Temperatures of the Baltic States // Electronics and Electrical Engineering. – Kaunas: Technologija, 2006. –No. 1(65). –P. 81–84.**

This article deals with a material saving technical solution for luminaires with tri-phosphorus fluorescent lamps, operated in low environmental temperatures. The resulting loss of luminous flux of the lamps at falling temperatures has to be improved, particular value is attached to a technically sound, constructive solution with an ideal cost-performance ratio. In the article is shown how to design a particularly low-priced and cost-efficient luminaire, and nevertheless at least still strongly reduce the undesirable loss of the luminous flux, in order to obtain an alternative solution for general outdoor lighting and for lighting in open buildings. A solution to this problem is presented. The problem has been solved by shaping the protecting tube on both ends over the adapter bushings, which function as heat accumulator, and which hold the heat accumulation tube III. 3, bibl. 6 (in English; summaries in Lithuanian, English, Russian).

**Ф. Прахт, А. Илгевичюс. Техническое решение снижения себестоимости материалов, используемых в осветителях с три - фосфорными флуоресцентными лампами, предназначенных для низкотемпературной среды // Электроника и электротехника. – Каунас: Технология, 2006. – №. 1(65). – С. 81–84.**

Предлагается техническое решение снижения себестоимости материалов, используемых в осветителях с три - фосфорными флуоресцентными лампами, предназначенных для низкотемпературной среды. В условиях низкой температуры суммарные потери светового потока должны быть снижены; также, большое внимание уделяется звуку, производимому лампой, конструктивным решениям, способствующим идеальному соотношению цены и качества. Решение проблемы было найдено с помощью деформации обоих концов защитной трубы лампы. В данных концах закрепляются держатели адаптера, который выполняет функцию аккумуляции тепла и держит трубку аккумуляции тепла. Внутренняя полость адаптера концами присоединяется к диффузору с ограниченным внутренним пространством. Ил. 5, библи. 16 (на английском языке; рефераты на литовском, английском и русском яз.).

**F. Pracht, A. Ilgevičius. Šviestuvų su trifosforinėmis fluorescencinėmis lempomis, skirtų žemoms aplinkos temperatūroms, savi kainos mažinimo Baltijos šalyse techninis sprendimas // Elektronika ir elektrotechnika.. – Kaunas: Technologija, 2006. – Nr. 1(65). –P. 81–84.**

Pateikiamas techninis sprendimas sumažinti šviestuvų su trifosforinėmis fluorescencinėmis lempomis, skirtų žemoms aplinkos temperatūroms, medžiagų savikainą. Analizuojami lempų šviesos srauto nuostoliai prie žemų temperatūrų. Aprašomi būdai lempų mechaninių triukšmų mažinimui. Optimizuojami konstruktyviniai sprendimai, kurie užtikrina idealų kainos ir kokybės santykį. Sprendimo būdas buvo rastas deformuojant apsauginį lempos vamzdį abiejuose galuose, kuriuose tvirtinami adapterio laikikliai ir kuris atlieka šilumos akumuliavimo funkciją bei kuris laiko šilumos akumuliavimo vamzdį. Adapterio vidinė ertmė yra sujungta per galus su riboto vidinio ploto difuzeriu, šilumos akumuliavimo vamzdžiu bei su galinėmis dalimis. Tokia konstrukcija užtikrina reikalaujamą tarp šių dalių oro cirkuliaciją. Il. 3, bibl. 6 (anglų kalba; santraukos lietuvių, anglų ir rusų k.).

