

## Power Electronic Two-phase Orthogonal System with HF Input and Variable Output

**B. Dobrucký, P. Špánik, M. Kabašta**

*Faculty of Electrical Engineering, University of Žilina, Slovakia  
 Univerzitná 1, 01026, Žilina, phone: +421515131601; e-mail: dobrucky@fel.utc.sk*

### Introduction

Classical way of the conversion uses DC link converters. In AC traction application it means: single-phase traction transformer (50/16.7 Hz), traction rectifier (4Q), voltage DC link, three-phase PWM traction inverter and three-phase traction motor, Fig.1:

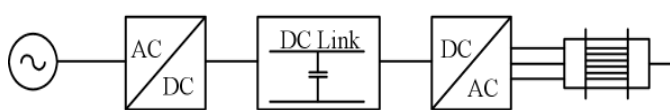

**Fig. 1.** Block scheme for indirect single- to three phase conversion using converters with DC link

Main disadvantage of this is bulk and heavy LF traction transformer and two serial connected traction converters, too. One way, how to solve that problem, is to provide supply of traction transformer by much higher frequency (e.g. 2-10 kHz) on primary side, and to use direct converter (type of matrix one) on secondary side, see Fig. 6 later. Since the first can be solved by various type of HV converters [2], [7], [11-14], [18], the later one brings need to use of single- to three-phase matrix converter with variable output voltage and frequency (e.g. 0-100 Hz). Such a matrix converter denotes itself by input power fluctuation, because its fictitious DC link voltage and also input power are not constant, see Figs. 2a,b:

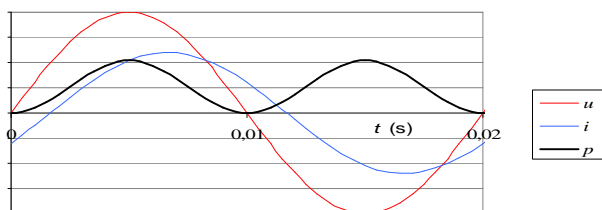

**Fig. 2a.** Fluctuation of single-phase active power

The average value of fictitious DC link voltage will then equal:

$$U_{1AV} = 2/\pi * U_{imax} = 0.637 U_{imax} . \quad (1)$$

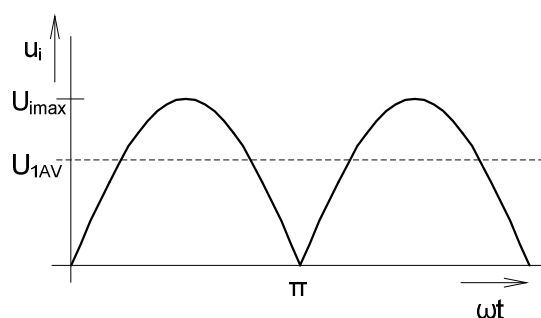

**Fig. 2b.** Fictitious DC link voltage of single-phase supply

On the contrary, the average value of fictitious DC link voltage in case of three-phase supply, Fig. 3, is much higher one:

$$U_{3AV} = 3/\pi * U_{imax} = 0.955 U_{imax} . \quad (2)$$

But, the average value of two-phase orthogonal system is very close to the three-phase system, and it's important that average value of active power of such a system is constant, see Fig. 3:

$$U_{2AV} = 2.\sqrt{2}/\pi * U_{imax} = 0.9 U_{imax} . \quad (3)$$

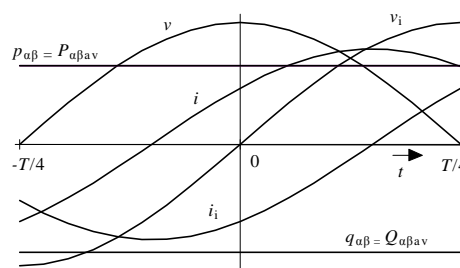

**Fig. 3.** Time-waveforms of instantaneous  $p_{\alpha\beta}$ ,  $q_{\alpha\beta}$  components [17]

In the Fig. 3 the average active power is [17]:

$$P_{av} = \frac{P_{\alpha\beta av}}{2} = \frac{2}{T} \int_0^{\frac{T}{4}} (u_{\alpha} \cdot i_{\alpha} + u_{\beta} \cdot i_{\beta}) \cdot dt, \quad (4)$$

and average reactive power

$$Q_{av} = \frac{Q_{\alpha\beta av}}{2} = \frac{2}{T} \int_0^{\frac{T}{4}} (u_{\alpha} \cdot i_{\beta} - u_{\beta} \cdot i_{\alpha}) dt. \quad (5)$$

Note: Phases of  $\alpha$  and  $\beta$  demonstrate two-phase orthogonal system.

### Direct Conversion from Single- to Three Phase using Matrix Converter

The matrix converter topology has become well known after substitution of thyristor-devices in cycloconverters by switched-off elements acting in high frequency range, in 70-80-years [1], [2]. One of the main advantages of that is unity power factor on its input side.

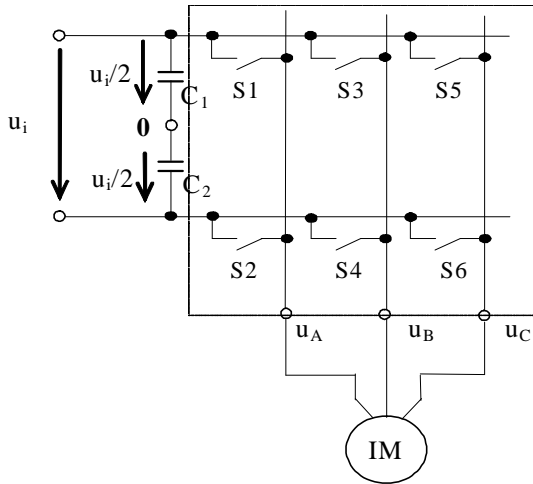

**Fig. 4.** The basic topology of single-to-three phase matrix converter

Besides, this converter offers sinusoidal input and output harmonics, bi-directional energy flow, elimination of DC-link circuit and decreasing of number of switching elements of converter in AC/AC drives. The basic topology of a single to three-phase matrix converter is shown in Fig. 4.

Based on this during a half-period of input voltage  $t \in (0^{\circ} - 180^{\circ})$  the potential of output terminal A is as follows:

$$+u_i/2 \quad S1 = \text{turn - on, } S2 = \text{turn - off} \quad (6a)$$

$$-u_i/2 \quad S1 = \text{turn - off, } S2 = \text{turn - on} \quad (6b)$$

These considerations are the same for output terminals B and C. Line-to-line voltage is:

$$u_{AB} = (u_{A0} - u_{B0}) \quad (7a)$$

$$u_{BC} = (u_{B0} - u_{C0}) \quad (7b)$$

$$u_{CA} = (u_{C0} - u_{A0}) \quad (7c)$$

The value of output phase voltage depends on switching commands as well as the instantaneous values of input voltage as the value of input voltage changes with given frequency. The reference value of output phase voltage can be reached by appropriate switching logic. Some of simulation results, showing power fluctuation in single-phase system are depicted in following Fig. 5.

Using FACTS (e.g. PAF – power active filter, UPFC – unified power flow controller, DVR – dynamic voltage restorer,..) it can be improved unsymmetry and harmonic content of the input and output currents.

Those FACTS can be connected on input- and also output side of the matrix converter. Main goal of them is elimination of power fluctuation of single-phase supply of the converter.

### Middle Frequency (MF) Traction Transformer with input HV cascade-connected converter

One of the main disadvantages of the classical system, bulk and heavy LF traction transformer, can be reduced by using of middle frequency transformer [2], [14], [19], probably with superconductive winding [20], [21], [22].

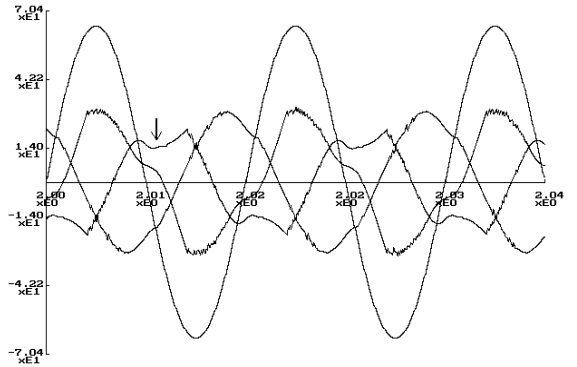

**Fig. 5.** Input voltage and output currents of one-to-three phase matrix converter IM drive [9]

It is true, that superconducting technology will be used if the applications provide an advantage over conventional technologies. They must be cost effective over materials lifetime, including capital costs, maintenance, reliability and availability. This is a basis on which a discussion about HT superconductive transformer can be started.

The core of the introduced converter is a HV modular multilevel converter structure (matrix or classical connection) [12-15], [19]. With the new converter concept (Fig. 6) a compact MF-transformer is fed directly by the single phase converter system which is operating on the AC line voltage. The concept facilitates four-quadrant operation and superior line-side behaviour under steady state and transient conditions. Passive LC-filters at the line side or resonant tank circuits tuned to the double line-frequency are eliminated.

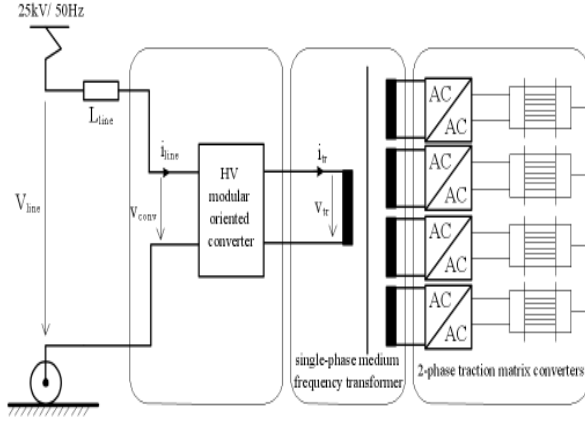
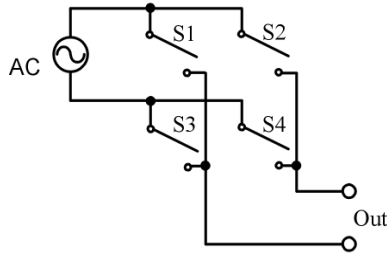

**Fig. 6.** New converter drive concept with single-to-two phase matrix converters

### Matrix Converter Subsystem with Two-Phase Orthogonal Induction Motor

#### A. Matrix Converters with Two-Phase Orthogonal Output Voltages

The basic scheme of single-phase matrix converter is shown in Fig. 7.



**Fig. 7.** Basic switching scheme of single-phase matrix converter

Relation between output and input voltages is as:

$$[v_o(t)] = [M(t)][v_i(t)] \quad (8)$$

and reciprocally

$$[v_i(t)] = [M(t)]^T [v_o(t)], \quad (9)$$

where  $[M(t)]$  – modulation matrix,  $[M(t)]^T$  transposed matrix,  $m_{aA}(t) = \frac{t_{aA}}{T_{seq}}$  – modulation index,  $t_{aA}$  – time of switched state, with restrictions (10):

$$\sum_{K=a,b,c} m_{KA}(T) = \sum_{K=a,b,c} m_{KB}(T) = \sum_{K=a,b,c} m_{KC}(T) = 1. \quad (10)$$

Output current can be expressed by differential equation:

$$[i_o(t)]' = [A][i_o(t)] + [B][v_o(t)]. \quad (11)$$

Simulation results for input frequency  $f_{IN} = 2\text{kHz}$  and output frequency  $f_{IN} = 100\text{Hz}$  are shown in Fig. 8–11.

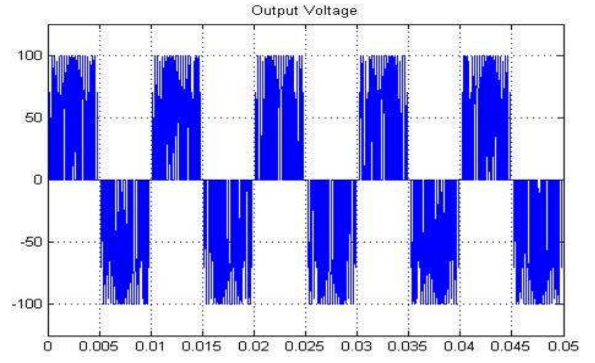

**Fig. 8.** Time waveform of output  $\alpha$ -voltage

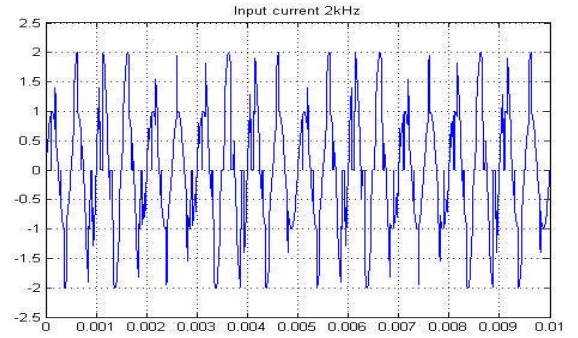

**Fig. 9.** Time waveform of output  $\beta$ -voltage

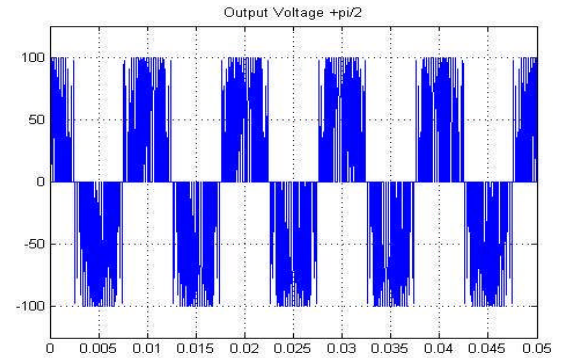

**Fig. 10.** Time waveform of input current

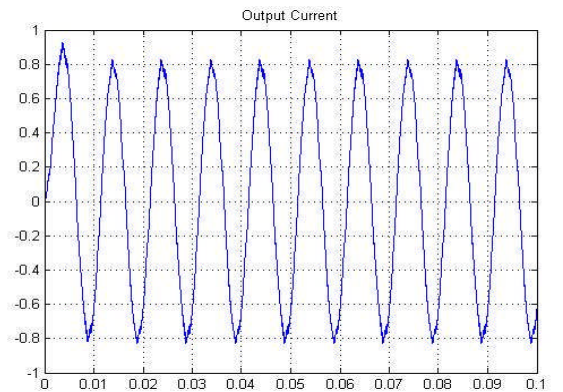

**Fig. 11.** Time waveform of output current

## B. Modelling of the system: matrix converter – two phase orthogonal driving motors

Supposing model of induction type of traction motor (equivalent scheme of an one phase), the mathematical model will be the same as model of three-phase induction motor, see matrix equation bellow.

$$\frac{d}{dt} \begin{pmatrix} i_{\alpha} \\ i_{\beta} \\ i_{\alpha R} \\ i_{\beta R} \\ \omega_R \end{pmatrix} = [A_{im}] \begin{pmatrix} i_{\alpha} \\ i_{\beta} \\ i_{\alpha R} \\ i_{\beta R} \\ \omega_R \end{pmatrix} + [B_{im}] \begin{pmatrix} v_{\alpha} \\ v_{\beta} \\ 0 \\ 0 \\ 0 \end{pmatrix}, \quad (12)$$

where  $[A_{im}]$  and  $[B_{im}]$  are matrix of the parameters of the driving (induction or synchronous) motor.

The only differences present the exciting voltages, where  $v_{\alpha}$  and  $v_{\beta}$  are now output voltages of both matrix converters.

## Experimental Verification of One-to Three Phase Matrix Converter with Three-Phase Induction Motor

So far, we have experimentally verified just operation of one-to three phase matrix converter supplied three-phase induction motor. Carried-out waveforms of output currents of matrix converter are shown in Fig. 12.

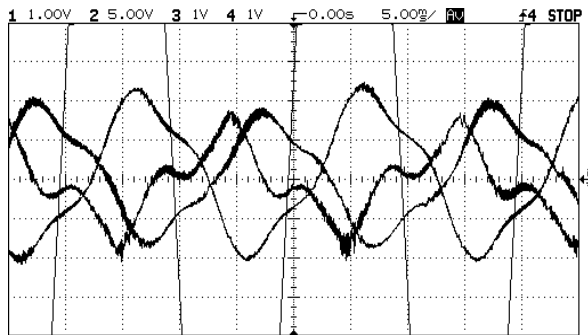

**Fig. 12.** Output currents of one-to-three phase matrix converter drive

The IM parameters are as follows: stator resistance 1,556  $\Omega$ , rotor resistance 2,08  $\Omega$ , stator inductance 0,2355 H, rotor inductance 0,2355 H, mutual inductance 0,2265 H, torque of inertia 0,071  $\text{kg.m}^2$ , 2 pole-pairs, constant load torque 0,05 Nm.

Experimental measurements were recorded under the following conditions: input voltage  $u_{i\max} = 54\text{V}$ , frequency of input voltage 50Hz, reference frequency 50Hz, switching frequency approximately 10 kHz. You can see that output currents of all three phases are very similar to those of Fig. 5b.

The works on preparing of experimental verification of two-phase Matrix converter orthogonal system are in progress.

## Comparison of Two-Phase Matrix Converter Orthogonal Driving Concept with Three-Phase VSI and Matrix Converter

### A. Matrix Converters with Two-Phase Orthogonal Output Voltages

Needs of power semiconductor devices (PSD) in basic connection:

$2 \times 4 = 8$  pcs of bidirectional IGBT switches.

Supposing that 1 bidirectional switch represents 2 IGBT and 2 diodes, so, we need actually 16 IGBT + 16 D.

Needs of power semiconductor devices in halfbridge connection:

$2 \times 2 = 4$  pcs of bidirectional IGBT switches,

i.e. 8 IGBT + 8 D.

Needs of power semiconductor devices with naturally source commutation in halfbridge connection (cycloconverter):

$2 \times 4 = 8$  pcs of fast SCR thyristors.

### B. One-to Three Phase Matrix Converter

Needs of power semiconductor devices in bridge connection:

$1 \times 6 = 6$  pcs of bilateral IGBT switches,

i.e. 12 IGBT + 12 D.

### C. Single-Phase 4QC and Three Phase VSI Converter

Needs of power semiconductor devices in classic connection:

$4 + 6 = 10$  pcs of simple IGBT switches

+ 10 freewheel diodes.

### D. Single-Phase 4QC and One-to-Three Phase Matrix Converter

Needs of power semiconductor devices in basic connection:

4 simple IGBT switches + 4 freewheel diodes,

+ 6 pcs of bilateral IGBT switches,.

i.e. 16 IGBT + 16 D in total.

## Conclusions

The concept of two-phase orthogonal matrix converter system shows an alternative to three-phase converter or one-to-three matrix converter. The main differences are:

- two-phase orthogonal system needs no-ordinary AC motor,
- three-phase system needs much number of power semiconductor devices.

Since the problem of AC motor lays on re-arranging and conditioning of the motor winding, the problem of

higher number of power semiconductor devices seems to be essential one:

- two-phase orthogonal system in halfbridge connection needs only 66,6 % devices as the one-to-three matrix converter system (4 bidirectional switches against 6),
- the cheapest variant of two-phase system is presented by using of 8 fast SCR thyristors naturally commutated,
- comparing three-phase systems with VSI- and 1/3 matrix converter has been already done in [5]: for higher switching frequencies (> 15 kHz) is better the latter one.

Using of two-phase orthogonal system is advantageously under condition of hf power supply. Anyway, this system is a new progressive method which can be useful for usage in electric traction or aircraft applications.

### Acknowledgment

The authors wish to thank for the financial support to Scientific Grant Agency of the Slovak Republic for the VEGA Project No. 1/3086/06, “*Research of the new methods of modelling, control and simulation of mechatronic systems*”, and NO. 1/3123/06 “*Research of Commutation Process in Power Transistor Structure at Soft Switching Techniques and Control Algorithm Optimisation*” and also “*Intelligent device for giguecycle fatigue test of construction materials which are being used in the field of ultrasonic frequencies*”, APVV Project No.20-051705

### References

1. **Hasegawa T.** Expectation for Power Conversion Technologies from the Electric Power Company // Invited paper. Proc. of IEEE-PCC'02 Conf. – Osaka, Japan. – April 2002. – Vol. 2. – P. 341–346.
2. **Wrede H.** Contribution to Enhancement of Supplying Safety and Voltage Quality in Transfer and Delivery of Electric Energy using Power Electronic Means (in German) / Dissertation Ruhr Universität Bochum (Germany), Shaker Publisher Aachen. – 2004.
3. **Iov F., Blaabjerg, Basset R., Clare J., Rufer A., Savio S., Biller P., Taylor P., Snayers B.** Advanced Power Converter for Universal and Flexible Power Management in Future Electricity Network // Proc. of CIRED'07 Int'l Conf. on Electricity Distribution. – Vienna, Austria. – May 2007.
4. **Chau K. T., Chan C. C., Wong Y. S.** Advanced Power Electronics Drives for Electric Vehicles // ElectroMotion. – April-June, 1998. – Vol. 5, No. 2. – P. 42–53.
5. **Szychta E.** Properties of Multiresonant DC converters // Przegląd Elektrotechniczny. – 2005. – No. 9. – P. 46–50.
6. **Gonthier L., Bernot F., Bocus S. D., Elbaroudi S., Berthon A.** High-Efficiency Soft-Commutated DC-AC-AC Converter for Electric Vehicles // ElectroMotion. – April-June, 1998. – Vol. 5, No. 2. – P. 54–64.
7. **Dobrucky B., Kucer P., Alexik M.** Fuzzy Control of AC Traction Drives // ElectroMotion. – April-June, 1998. – Vol. 5, No. 2. – P. 65–74.
8. **Rufer Ch., Schibli N., Briguet Ch.** A Direct Coupled 4-Quadrant Multilevel Converter for 16 2/3 Hz Traction Systems // Proc. of PEVD'96 Int'l Conf., London (UK). – Sept. 1996. – P. 448–453.
9. **Steiner M., Deplazes R., Stemmler H.** A New Transformerless Topology for AC-Fed Traction Vehicles using Multi-Star Induction Motors // Proc. of EPE'99 Int'l Conf., Lausanne (CH). – Sept. 1999 (CD-ROM).
10. **Dobrucky B., Havrila R., Dubovský J.** A Single-Phase Supplied Matrix Converter with Unity Power Factor // Proc. of EPE-PEMC'98 Int'l Conf., Prague (CZ). – Sept. 1998. – P. 6.146–6.150.
11. **Dubovský J., Dobrucky B., Tabaček R., Havrila R.** A DSP Controlled One-to-Three Phase Matrix Converter // Proc. of FINPIE '97 Int'l Seminar, Helsinki, Espoo (FI). – Aug. 1997. – P. 121–125.
12. **Erickson R. W., Al-Naseem O. A.** A New Family of Matrix Converters // Proc. of IEEE Industrial Electronics Society Annual Conf. – Nov./Dec. 2001. – Vol. 2. – P. 1515–1520.
13. **Glinka M., Marquardt R.** A New Single-Phase AC/AC-Multilevel Converter for Traction Vehicles Operating on AC Line Voltage // Proc. of EPE'03 Int'l Conf., Toulouse, France. – Sept. 2003 (CD-ROM).
14. **Kalvelage, Ph. Aubine, Lequeu Th.** Reduction of Mass and Volume of On-Board Multi-Input Voltage Converters Using SPARC Topology // Proc. of EPE'03 Int'l Conf., Toulouse, France. – Sept. 2003 (CD-ROM).
15. **Wrede V. Staudt, Steimel A.** A Soft-Switched Dual Active Bridge 3DC to IDC Converter Employed in HV Electronic Power Transformer // Proc. of EPE'03 Int'l Conf., Toulouse, France. – Sept. 2003 (CD-ROM).
16. **Dobrucky B., Drozdy S., Pokorný M., Pavlanin R.** Instantaneous Power Flow Determination for Single-Phase UPFC // Proc. of IASTED EuroPES'07 Int'l Conf., Palma de Mallorca, Spain. – Aug. 2007. – P. 426–431.
17. **Viktorin O., Driesen J., Belmans R.** The Prototype of a Single-phase Dynamic Voltage Restorer // Proc. of EPE-PEMC'04 Conf. – Riga, Latvia. – Sept. 2004. – Vol. 6 (CD-ROM).
18. **Dobrucky B., Pokorný M., Racek V., Havrila R.** A New Method of the Instantaneous Reactive Power Determination for Single-Phase Power Electronic Systems // Proc. of EPE'99 Conf., Lausanne (CH). – Sept. 1999 (CD-ROM).
19. **Macken K. J. P., Driesen J. J. L., Belmans R. J. M.** Comparison of a Step-Up Converter and an Electronic DC Transformer with respect to Component Stress // Proc. of EPE'01 Int'l Conf., Graz, Austria. – Sept. 2001 (CD-ROM).
20. **Meinert M., Leghissa M., Schlosser R., Schmidt H.** System Test of a 1-MVA-HTS-Transformer Connected to a Converter-Fed Drive for Rail Vehicles // IEEE Trans. on Applied Superconductivity ASC 2002. – Houston, USA. – August 5–9, 2002.
21. **Meinert M.** HT-Superconductive Transformer for Future Railway Rolling Stocks (in German) / Dissertation. – Supervisors A. Binder, T. Laitfried, Dept. of Energy Conversion, TU Darmstadt, Germany. – 2006.
22. **Kamijo H. Hata, Fujimoto H., Inoue A., Nagashima K., Ikeda K., Iwakuma M., Funaki K., Sanuki Y., Tomioka A., Yamada H., Uwamori K., Yoshida S.** Test of Superconducting Traction Transformer for Railway Rolling Stock // IEEE Trans. on Applied Superconductivity. – June 2007. – Vol. 117, No.2. – P. 1927–1930.
23. **Szychta E., Luft M.** Comparative Analysis of Simulation and Analytic Testing of Multiresonant DC/DC Boost Converter // 11<sup>th</sup> TRANSCOMP 2007 Int'l Conf. – Radom University of Technology. – 2007. – P. 491–497.
24. **Rafajdus P., Hrabovcova V.** Superconducting Transformer Thermal Model // Proc. of The Joint CZ-PL-SK Int'l Conf., under GACR project No. 102/06/1320. – Brno-Slapanice. – Nov. 2007 (CD-ROM).
25. **Kováč D., Kováčová I.** Converter's Electromagnetic Compatibility Investigation // Proceeding of 11th

International Conference Electrical Drives and Power Electronics. – Dubrovnik, Croatia. – 2000. – P. 55–57.

26. **Pittermann M., Drabek P., Cedi M., Fort J.** The Study of the Traction Drive with Middle-Frequency Transformer // Proc. of TRANSCOM'07 Int'l Conf. – Zilina (SK). – June 2007. – P. 159–162.
27. **Dobrucky B., Marcokova M., Kabasta M.** Using Orthogonal Transform for Investigation of Matrix Converter Power Circumstances in *Mathematica* Environment // Proc.

of Aplimat'08 Int'l Conf. on Applied Mathematics. – Bratislava (SK). – Feb. 2008 (CD-ROM).

Received 2008 10 10

**B. Dobrucký, P. Špánik, M. Kabašta. Power Electronic Two-phase Orthogonal System with HF Input and Variable Output // Electronics and Electrical Engineering. – Kaunas: Technologija, 2009. – No. 1(89). – P. 9–14.**

The paper deals with the direct single- to two-phase conversion system as a new version of classical indirect single- to three-phase conversion system with DC link. It's supposed that such a system will supply two-phase synchronous or induction motors. The proposed drive in comparison with currently used conventional drives reduces the number of power switching elements of the converter, also heavy and bulky DC link, which increases the drive's dependability and reliability, and brings lower investment in power electronics used in drive. The system can be used in high power traction application as well as in lower power aircraft application using HF traction transformer or HF generator, respectively. Il. 12, bibl. 27 (in English; summaries in English, Russian and Lithuanian).

**Б. Добруцки, П. Шпаник, М. Кабашта. Мощная двухфазная ортогональная электронная система с ВЧ входом и переменным выходом // Электроника и электротехника. – Каунас: Технология, 2009. – № 1(89). – С. 9–14.**

Анализируются способы преобразования однофазного постоянного тока в двухфазный. Предлагаемая система преобразования используется для синхронных двигателей. Показано, что такая система отличается повышенной надежностью и значительно уменьшает стоимость. Рекомендуется такие системы использовать в авиации. Ил. 12, библи. 27 (на английском языке; рефераты на английском, русском и литовском яз.).

**B. Dobrucký, P. Špánik, M. Kabašta. Galinga dvifazė ortogonalioji elektroninė sistema su aukštojo dažnio įėjimu ir kintamu išėjimu // Elektronika ir elektrotechnika. – Kaunas: Technologija, 2009. – Nr. 1(89). – P. 9–14.**

Nagrinėjama tiesioginio elektros srovės keitimo iš vienfazės į dvifazę sistema. Ji analizuojama kaip nauja klasikinio netiesioginio elektros srovės keitimo iš vienfazės į trifazę sistemos su nuolatinės srovės grandimi versija. Daroma prielaida, kad tokia sistema tiek dvifazę srovę sinchroniniams arba indukciniam varikliams. Palyginti su dabartiniu metu naudojamas įprastinių tipų varikliais, siūlomasis variklis sumažina galios komutavimo elementų poreikį keitiklyje, leidžia atsisakyti sunkios ir masyvos nuolatinės srovės grandies, o tai padidina variklio patikimumą ir efektyvumą. Be to, tai leidžia sumažinti variklyje naudojamos galios elektronikos kainą. Sistema gali būti naudojama aviacijoje. Il. 12, bibl. 27 (anglų kalba, santraukos anglų, rusų ir lietuvių k.).

DOI: 10.5755/j02.eie.10541