

Rational Supply System of Components for Electronic Devices

V. Stupak

Department of Public Safety, Mykolas Romeris University

V. Putvinskio str. 70, LT – 44211 Kaunas ACP, Lithuania, phone: +370 37 303645, e-mail: v.stupak@mruni.lt

Introduction

For ensuring the reliability of electronic devices in exploitation, certain stocks of necessary component are provided. For this purpose, the supply system of components of electronic devices is planned [1].

Given reliability can be provided by certain structures of supply systems of components. In turn, there is a task of defining of the best, in the certain sense, supply systems of components.

The article offers the method of definition of rational structure of supply system of components for electronic devices. The index of expenses describing the cost of stocks of a component is considered. The definition of rational structure of supply system of components is carried out regarding restrictions on values of index of sufficiency or an index of expenses.

Structures of supply systems of components for electronic devices

In providing electronic devices with necessary components, various structures of stocks of a component are applied [2]. For the formation of possible structures, three kinds of complete sets of a component shall be considered.

Complete sets of the first kind are intended for the concrete electronic device.

Complete sets of the second kind are used for a group of electronic devices. They are intended for supplementing complete sets of the first kind. Also, they can be applied in providing electronic devices with components of the types, the stocks of which are not present in complete sets of the first kind.

Complete sets of the third kind are intended for repair institution and provide its functioning.

Functioning of repair institution is based on the use of the certain technology of repair of electronic devices. The technology of repair of electronic devices to a certain degree depends on levels of technological complexity of used component. Let's consider, for example, a case of the following three levels of complexity a component. Components of the first level are no repairable items. Components of the second level will consist of components of the first level. Moreover repair of a

component of the second level is based on the replacement of damaged component of the first level. Components of the third level will consist of components of the second level, and their repair is based on the replacement of components of the second level.

Thus, the variety of structures of supply systems of components put into practice is influenced by kinds of complete sets of components and levels of technological complexity of components. Possible structures of supply systems of components can be subdivided into two classes– the first and the second. Structures of the first class contain one of the complete sets of components considered above. Structures of the second class are more complex. They provide the use of two and more various complete sets of components.

Possible variants of structures of supply systems of components are presented in Fig. 1–5. Structures of the first class are presented in Fig. 1–3, structures of the second class – in Fig. 4 and Fig. 5.

Fig. 1 presents the structure of supply systems with the components, based on the use of complete sets of first kind CS₁. Here, the following symbols are used: PSU – a primary source of supplementing of complete sets which is supposed to be inexhaustible; RO – the repair institution; ED – the electronic device. Each of electronic devices of considered type is provided with components from separate complete set CS₁ during exploitation. Complete sets CS₁ are supplement from RO. At the expenditure of stocks of components in repair institution, they are supplemented from PSU. The opportunity of supplementing complete sets CS₁ in full or in part from PSU is also possible.

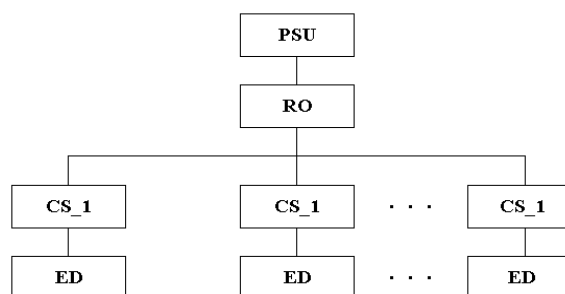

Fig. 1. Structure of supply system of components in which complete sets of the first kind CS₁ are used

In Fig. 2, the variant of structure of supply system of components, using of complete sets of the second kind CS₂ is presented. At the exploitation of group of electronic devices of considered type, components from one complete set CS₂ are used. Complete set CS₂ is supplemented from RO. At an expenditure of stocks of components in repair institution, they are supplemented from PSU. The opportunity of supplementing the complete set CS₂ in full or in part from PSU is also possible.

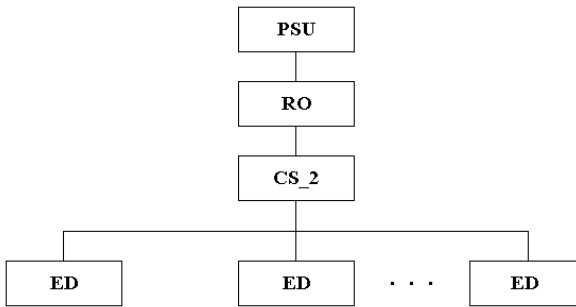

Fig. 2. Structure of supply system of components in which the complete set of the second kind CS₂ is used

In Fig. 3 the variant of structure of provision with the components, using the complete set of the third kind CS₃ is considered. Stocks of components from complete set CS₃ for repair institution RO is intended. Complete set CS₃ is supplemented from PSU. The option of RO being supplemented in part from source PSU is also possible.

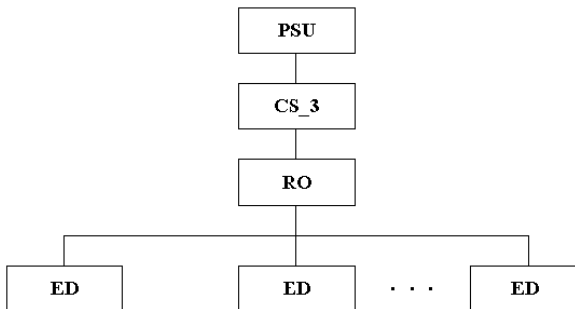

Fig. 3. Structure of supply system of components in which the complete set of the third kind CS₃ is used

In Fig. 4, the structure of supply system with components that uses complete sets of the first and the third kinds is considered. At exploitation of group of the same electronic devices, each of them uses complete sets CS₁. At an expenditure of stocks of components in CS₁, they are supplemented from RO. Repair institution RO, in turn, is supplemented from complete set CS₃. Only complete set CS₃ is supplemented from PSU. The given structure can have options at which complete sets CS₁ or RO in part are supplemented from PSU.

In Fig. 5, the structure of supply system of components, in which complete sets of the first, second and third kinds are used, is presented. At exploitation of group of the same electronic devices, each of them uses complete sets CS₁. At an expenditure of stocks of components in CS₁, they are supplemented from CS₂. Complete set CS₂ is supplemented from RO. Repair

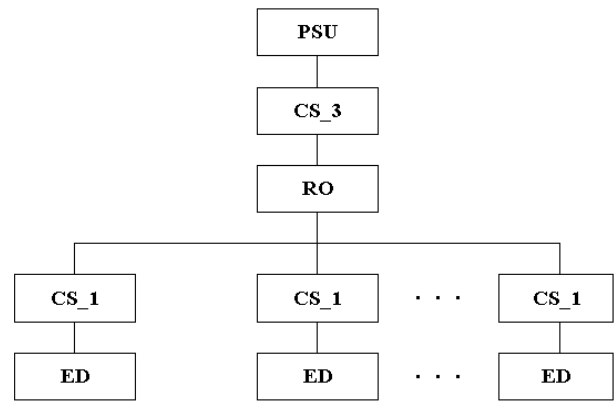

Fig. 4. Structure of supply system of components in which complete sets of the first CS₁ and the third CS₃ kinds are used

institution RO, in turn, is supplemented from complete set CS₃. And complete set CS₃ is supplemented from PSU. The given structure can also have such options at which complete sets CS₁, CS₂ and RO in part are supplemented from PSU.

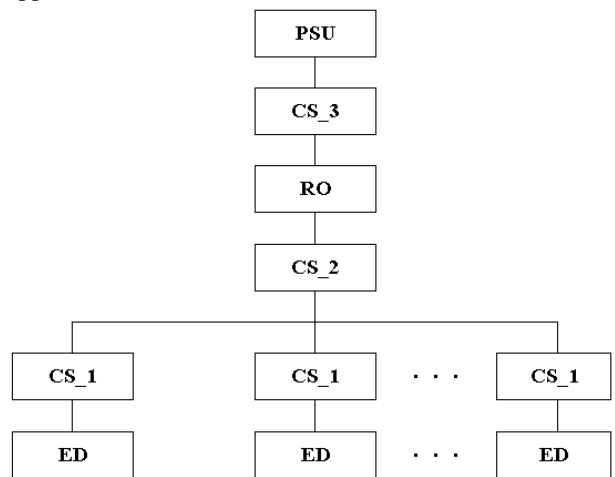

Fig. 5. Structure of supply system of components from complete sets of the first CS₁, the second CS₂ and the third CS₃ kinds

The structures presented in figures 1÷5 do not completely reflect possible variety of supply systems of components. As it has been specified above, they can be added with structures in that, for example, complete sets CS₁ and/or CS₂ in part are supplemented from PSU. Also, structures of supply system of components in which complete sets of the first and second kinds are simultaneously used, and of the second and third kinds are not presented. Besides, the supply systems containing more of various kinds of complete sets of components, not three, can be used.

Method of defining rational structure of supply system of components for electronic devices

It is obvious that there is a certain set of structures of supply systems of components, allowing reaching preset values of an index of sufficiency of stocks. Let's stop at the formulation of conditions for defining rational structure of supply system of components.

Let's take into account that restrictions on expenses or on an index of sufficiency can be set. Further, we shall proceed to the analysis of possible structures of supply system of components (fig. 1÷5). For each of the given structures, we shall define the generalized index of sufficiency of stocks U_{Sj} and total expenses for components C_{Sj} , ($j = \overline{1, W}$).

At restrictions on total expenses, the following formulation for definition of rational structure is correct:

$$\begin{cases} U_{SF} = \max \{ U_{S1}, U_{S2}, \dots, U_{SF}, \dots, U_{SJ} \}, \\ C_{SF} \leq C_{S*}, \end{cases} \quad (1)$$

where J – the quantity of structures of supply system of components, for which $C_{Sh} \leq C_{S*}$, $h = \overline{1, J}$; C_{S*} – the set restriction on a index C_S .

At restrictions on an index of sufficiency, correct conditions for definition of rational structure will be the following:

$$\begin{cases} U_{SG} \geq U_{S*}, \\ C_{SG} = \min \{ C_{S1}, C_{S2}, \dots, C_{SG}, \dots, C_{SM} \}, \end{cases} \quad (2)$$

where M – the quantity of structures of supply system of components, for which $U_{Si} \geq U_{S*}$, ($i = \overline{1, M}$); U_{S*} – the set restriction on a parameter U_S .

As an index of sufficiency of stocks of components, the following indexes are applied, as a rule [3]: probability of sufficiency of stocks, index of availability of stocks, and the average time of a delay in realization of the application of components. The form of recording of expression (1) and (2) is completely suitable the analysis of probability of sufficiency of stocks and index of availability of stocks. In considering the delay in realization of the application of components, in (1) operation “max“ must be replaced with “min“ and in (2), $U_{Si} \geq U_{S*}$ must be replaced $U_{Si} \leq U_{S*}$.

The algorithm of definition of structure from their set for a condition of rationality (1) will be the following.

Step 1. The calculation of all complete sets the component, which is included in certain structure, is carried out. The given operations are provided for all analyzed structures ($j = \overline{1, W}$).

Direct and return tasks of calculation of complete sets of components can be attributed to the tasks of mathematical programming [4-6]. By analogy with [3,7], let's stop on the analysis of a case, when stocks of components are formed for the complete set of second kind CS_2.

Index of sufficiency of stocks will be considered as the probability of sufficiency P_2 determined for the period of supplementation T_p . Calculation of stocks for a direct task of calculation is done on the basis of the following conditions:

$$P(T_p) = \prod_{l=1}^L P_{1l} \geq P_*, \quad (3)$$

$$Z = \sum_{l=1}^L Z_l n_l \rightarrow \min_{n_l}, \quad (4)$$

where P_{1l} – the probability of sufficiency of stocks of a component of type l ; P_* – the required value of an index $P(T_p)$; Z – the cost of stocks of the components necessary for exploitation N of electronic devices during T_p , N – the quantity of electronic devices for which stocks of a component are calculated; Z_l – cost of components of type l , ($l = \overline{1, L}$); n_l – volume of stocks of components of type l .

Definition of stocks of a component for a return task of calculation can be carried out on the basis of conditions:

$$P(T_p) = \prod_{l=1}^L P_{1l} \rightarrow \max_{n_l}, \quad (5)$$

$$Z = \sum_{l=1}^L Z_l n_l \leq Z_*, \quad (6)$$

where Z_* – the set restriction on a cost index of stocks of components.

Probability of sufficiency P_{1l} is defined under the following formulas:

$$P_{1l} = \sum_{k=0}^{n_l} \frac{X_l^k}{k!} \exp(-X_l), \quad (7)$$

$$X_l = NT_p \lambda_{1l} m_l, \quad (8)$$

where X_l – average of applications in repair institution for components of type l ; λ_{1l} – failure rate of a component of type l ; m_l – quantity of components of type l in the electronic device.

Step 2. The generalized index of sufficiency U_{Sj} for each of structures ($j = \overline{1, W}$) is calculated. The method of defining generalized index is not discussed further.

Step 3. Total expenses C_{Sj} on components each of structures ($j = \overline{1, W}$) are calculated. For this purpose, the group of N electronic devices for the period of exploitation T_p is analyzed.

Step 4. J ($J \leq W$) structures from their set in total W , for which $C_{Sh} \leq C_{S*}$, ($h = \overline{1, J}$), are defined.

Step 5. The structure in which $U_{SF} = \max \{ U_{S1}, U_{S2}, \dots, U_{SF}, \dots, U_{SJ} \}$ is selected from the structures determined in the previous step. The F structure determined by the given way corresponds the condition of rationality set (1).

The algorithm of the choice of a mode from their set for a condition of rationality (2) is the following.

Step 1 and *Step 2*, in this case, involve the actions similar to the specified ones in the algorithm discussed above.

Step 3. M ($M \leq W$) structures from their set in total W , for which $U_{S_i} \geq U_{S^*}$, ($i = \overline{1, M}$) are defined.

Step 4. Total expenses for components C_{S_i} for each of the found structures ($i = \overline{1, M}$) are calculated.

Step 5. The structure in which $C_{SG} = \min\{C_{S1}, C_{S2}, \dots, C_{SG}, \dots, C_{SM}\}$ is selected from certain M structures. Apparently, the G structure corresponds the condition of rationality set (2).

Conclusions

1. Restorable electronic devices are considered. The method of defining rational structure of supply system of components of devices is offered.

2. A number of possible structures of supply system of components are generated. The case of presence of one, two and three complete sets of components in each of structures is considered. The components with three levels of technological complexity are analyzed.

3. At defining the rational structure, the generalized parameter of sufficiency of stocks U_{S_j} and total expenses for components C_{S_j} , ($j = \overline{1, W}$) for each of them is calculated. As an index of sufficiency of stocks of components, the following indexes are applied: probability of sufficiency of stocks, index of availability of stocks, and average time of the delay in realization of the application for components.

V. Stupak. Rational Supply System of Components for Electronic Devices // *Elektronics and Electrical Engineering*. – Kaunas: *Technologija*, 2009. – No. 2(90) – P. 51–54.

The restorable electronic devices are investigated. The system of ensuring with components used for realization of repair of devices is analyzed. The method of defining rational structure of supply system of components of devices is offered. A number of possible structures of supply system of components are generated. The case of presence of one, two and three complete sets a component in each of structures is considered. The components with three levels of technological complexity are analyzed. Definition of rational structure of supply system of components is carried out in view of restrictions on values of an index of sufficiency of stocks or an index of expenses. The index of expenses describing cost of stocks of components is considered. As an index of sufficiency of stocks of components, probability of sufficiency of stocks, index of availability of stocks, and average time of the delay in realization of the application for components are applied. The method of defining rational structure is carried out according to the developed algorithms. Ill. 5, bibl. 7 (in English; summaries in English, Russian and Lithuanian).

V. Ступак. Рациональная система обеспечения электронных устройств компонентами // *Электроника и электротехника*. – Каунас: *Технология*, 2009. – № 2(90) – С. 51–54.

Рассматриваются восстанавливаемые электронные устройства. Анализируется система обеспечения компонентами, используемыми для проведения ремонта устройств. Предлагается метод определения рациональной структуры системы обеспечения устройств компонентами. Сформирован ряд возможных структур системы обеспечения компонентами. Рассматривается случай наличия одного, двух и трёх комплектов компонент в каждой из структур. Анализируются компоненты, имеющие три уровня технологической сложности. Определение рациональной структуры системы обеспечения компонентами осуществляют с учётом ограничений на значения показателя достаточности запасов или же показателя затрат. Рассматривается показатель затрат, характеризующий стоимость запасов компонент. В качестве показателя достаточности анализируются вероятность достаточности запасов, коэффициент готовности запасов и среднее время задержки в удовлетворении заявки на компоненты. Метод определения рациональной структуры осуществляется в соответствии с разработанными алгоритмами. Ил. 5, библи. 7 (на английском языке; рефераты на английском, русском и литовском яз.).

V. Stupak. Racionali elektroninių įtaisų aprūpinimo komponentais sistema // *Elektronika ir elektrotechnika*. – Kaunas: *Technologija*, 2009. – Nr. 2(90) – P. 51–54.

Nagrinėjami elektroniniai įtaisai, kurie eksploatacijos metu yra taisomi. Analizuojama aprūpinimo komponentais būtinoms remonto darbams atlikti sistema. Siūlomas elektroninių įtaisų aprūpinimo komponentais sistemos racionalios struktūros nustatymo metodas. Suformuota keletas galimų aprūpinimo komponentais sistemos struktūrų. Nagrinėjamas atvejis, kai struktūrose numatyti vienas, du arba trys komponentų komplektai. Analizuojami komponentai, turintys trys technologinio sudėtingumo lygius. Aprūpinimo komponentais sistemos racionalios struktūros nustatomos atsižvelgiant į atsargų pakankamumo rodikliui arba išlaidų rodikliui nustatytus reikalavimus. Nagrinėjamas išlaidų rodiklis, apibūdinantis suminę komponentų atsargų kainą. Kaip komponentų atsargų pakankamumą apibūdinantis rodikliai analizuojama atsargų pakankamumo tikimybė, atsargų parengties koeficientas ir vidutinė paraiškos aptarnavimo komponentams vėlavimo trukmė. Pateikiami racionalios struktūros nustatymo algoritmai. Il. 5, bibl. 7 (anglų kalba; santraukos anglų, rusų ir lietuvių k.).

4. Definition of rational structure at restrictions on total expenses is carried out on the basis of condition (1). In turn, definition of rational structure at restrictions on the generalized parameter of sufficiency is carried on the basis of condition (2). The developed algorithms of definition of rational structure are also used for this purpose.

References

1. **Balaišis P., Eidukas D.** Elektroninių įtaisų patikimumas ir eksploatacija. II knyga. Elektroninių įtaisų eksploatacija. – Kaunas: Technologija, 2002. – 262 p.
2. **Головин И. Н., Чуварыгин Б. В., Шура – Бура А. Э.** Расчёт и оптимизация комплектов запасных элементов радиоэлектронных систем. – Москва: Радио и связь, 1984. – 176 с.
3. **Stupak V.** Analysis of component supply system for electronic devices // *Elektronics and Electrical Engineering*. – Kaunas: Technologija, 2006. – No. 8(72) – P. 83–86.
4. **Nash S. G., Sofer A.** Linear and nonlinear programming. – McGraw – Hill, 1995. – 692 p.
5. **Bertsekas D. P.** Nonlinear programming, 2nd edition – Athena Scientific, 1999. – 780 p.
6. **Bazaraa M. S., Sherali H. D., Shetty C. M.** Nonlinear programming: theory and algorithms, 3rd edition. – John Wiley & Sons, 2006. – 872 p
7. **Stupak V.** The evaluation of stocks of components for electronic devices // *Elektronics and Electrical Engineering*. – Kaunas: Technologija, 2007. – No. 8(80) – P. 19–22.

Received 2008 11 29

DOI: 10.5755/j02.eie.10505