

## The Reflection of Plane Electromagnetic Wave from Dielectric Slab with Metallic Lattice Inside

J. Ziemelis, T. Solovjova

Department of Radioelectronics, Faculty of Electronic and Telecommunications, Riga Technical University, Azenes str. 12, LV-1048, Riga, Latvia; e-mails: ziemelis@rsf.rtu.lv; solovjova@rsf.rtu.lv

### Introduction

For wave propagation simulation in room the mathematical models of walls are necessary [1]. Practically, walls are not simple dielectric layers with simply measurable complex permittivity. Generally, walls contain certain number of layers with different permittivity and conductivity, for example, gas-concrete wall with brick boarding and rockwool heat-insulation. For microwave frequencies, plastering also has influence on the reflection and transmission of ray. The simulation will be more complicated if layered structure contains different obstacles, for example, metallic structures in concrete. If metallic structures are threading the wall, the model will be more complex [2], [3], [4]. Usually, metallic structures in composite materials or in walls have regular placement. For example, in reinforced-concrete, metallic wires are shaped as a regular grating (Fig. 1).

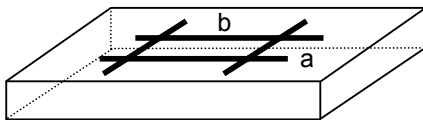

Fig. 1. The slab of reinforced concrete

Slab parameters depend on  $a$  and  $b$  grating dimensions. If dimension is comparable or greater as wavelength in concrete, than permittivity will be periodical function of space co-ordinate. If dimension is smaller as wavelength in concrete, than permittivity will be approximate constant for equivalent slab. The orientation of field polarisation with respect to wire orientation is important too, because regular grating is a combination from two perpendicular diffraction gratings. This paper contains our findings of concrete structure with copper grating, which dimensions are small, comparing with wavelength.

### Metallic structure in concrete

Model for research contains slab of concrete with thickness  $d$  and small metallic structure inside (Fig. 2). The thickness of metallic structure  $d_2$ .

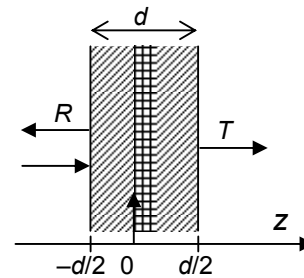

Fig. 2. Cross-section of slab

Let electromagnetic wave incidence be normal to slab. Every layer is characterised by thickness and complex dielectric permittivity at frequency  $f$

$$\varepsilon_{ci} = \varepsilon_i - i \cdot \frac{\sigma_i}{2 \cdot \pi \cdot f \cdot \varepsilon_0}, \quad (1)$$

wave impedance

$$Z_i = Z_0 / \sqrt{\varepsilon_{ci}} \quad (2)$$

and wave number

$$k_i = k_0 \cdot \sqrt{\varepsilon_{ci}}, \quad (3)$$

where  $Z_0 = \sqrt{\mu_0 / \varepsilon_0}$ ;

$$k_0 = 2\pi \cdot f \cdot \sqrt{\varepsilon_0 \cdot \mu_0};$$

$\varepsilon_i$  – relative dielectric constant of slab  $i$ ;

$\sigma_i$  – conductivity [ $\text{S} \cdot \text{m}^{-1}$ ] of slab  $i$ ;

$$\mu_0 = 4\pi \cdot 10^{-7} [\text{H} \cdot \text{m}^{-1}];$$

$$\varepsilon_0 = 10^{-9} / (36\pi) [\text{F} \cdot \text{m}^{-1}].$$

$R$  and  $T$  are reflection and transmission coefficients of slab. For simple materials  $R$  and  $T$  can be easily calculated by solving system of equations. The mathematical model of wall is a system of equations, resulting from boundary conditions for electrical and magnetic field intensity continuities on layer boundaries.

Electrical field intensity in layer  $i$  can be represented as a pair of travelling waves:

$$A_i \cdot \exp(-i \cdot k_i \cdot z) + B_i \cdot \exp(i \cdot k_i \cdot z). \quad (4)$$

For example,  $A_0$  stands for incident wave intensity on the wall and  $B_0/A_0$  represents reflection coefficient. After solving system of equations the field distribution in every layer is definite.

In our case middle layer has non-homogeneous structure. There are tempting attempts in literature to create equivalent permittivity for metallic grid. To get a simple estimation, the ratio between the area occupied by the metallic structure in  $x$ - $y$  plane and the total area of the slab  $\rho_w$  can be applied. The complex permittivity of slab with grid with dimensions that are smaller than the wavelength is estimated as per [2]:

$$\varepsilon_{ekv} = (1 - \rho_w) \cdot \varepsilon_0 \cdot \varepsilon_{concrete} - i \cdot \rho_w \cdot \sigma_{metall} / \omega, \quad (5)$$

where  $\sigma_{metall}$  – conductivity of wires;  $\omega$  – angular frequency.

Let structure have dimensions  $d_1=0.2$  [m],  $d_2=10^{-5}$  [m],  $d_3=0.2$ [m]. Concrete has permittivity  $\varepsilon_{concrete} = 6.25$  and conductivity  $\sigma_{concrete} = 0.037$  [S·m<sup>-1</sup>]. Grid is created from Cu with conductivity  $\sigma_{metall} = 5.8 \cdot 10^7$  [S·m<sup>-1</sup>]. Calculations are carried out at frequency  $f=2.4$  [GHz].

**Table 1.** Results

$\rho_w$	$ R $	$ T $
0	0.390557	0.272871
$10^{-6}$	0.405266	0.258157
$10^{-4}$	0.622684	0.040728
$10^{-2}$	0.662922	$4.7481 \cdot 10^{-4}$
0.1	0.663304	$3.0771 \cdot 10^{-5}$
1	0.663378	$6.3895 \cdot 10^{-8}$

The results of calculating show that for small area, occupied by metal, the grating works like a continuous metallic plane. These results cast some doubt upon this method. Therefore we suggest method for well-founded study of this problem.

Metallic structure is selected as flat structure because for cylindrical wire grid the ratio of occupied area depends on co-ordinate. For simplicity, the metallic grid is presented as a thin plane with rectangular windows and thickness  $d_2$ . The width of frame is denoted  $d_e$ . The system of Cartesian co-ordinates  $x_1$  and  $y_1$  are coupled with grid and can be rotated in regard to system, coupled with incident electromagnetic field (Fig. 3). The incident field polarisation coupled with Cartesian system co-ordinates  $x$  and  $y$ . The angle between axis  $x$  and  $x_1$  is  $\varphi$ .

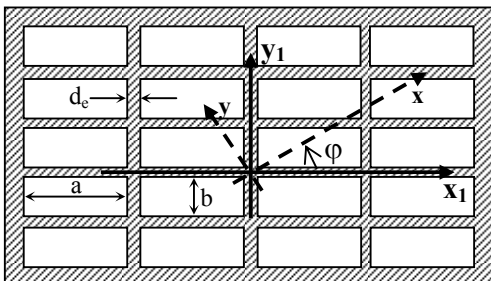

**Fig.3.** The shape of grid

The idea of the studied method is that the incident field creates current density in metallic frames of the structure. These currents create reflected and transmitted waves. In addition, the field in the windows creates the field behind the grid, according to Huygens principle. The currents in frames and field intensity in windows are fixed approximately. The current density in frames is obtained by solving 3 layers problem for  $\rho_w=1$ . Electrical field intensity in metallic layer gives  $\vec{j} = \sigma_{metall} \cdot \vec{E}_2$ . The electromagnetic field intensities in windows are obtained by solving simple boundary problem for free space-concrete, and calculating electric and magnetic fields in concrete at dept  $d/2$ .

If incident field polarized along  $x$  axis  $E_x$  the

$$E_{x1} = E_x \cdot \cos(\varphi) \text{ and } E_{y1} = E_x \cdot \sin(\varphi). \quad (6)$$

The current density  $\vec{j}$  has components  $j_{x1}$  and  $j_{y1}$ , and creates electromagnetic field that can be expressed by vector potential  $\vec{A}$ . Vector potential satisfies equation:

$$\nabla^2 \mathbf{A}_{x_1, y_1} + k_1^2 \cdot \mathbf{A}_{x_1, y_1} = -\mu_0 \cdot \mathbf{j}_{x_1, y_1}. \quad (7)$$

The solution of Helmholtz equation (2) for boundless room can be expressed by Green function [5]. This is vector potential for radiated field. The solving for  $A_{x1}$ :

$$\begin{aligned} A_{x1}(x_1, y_1, z) = \\ = \frac{\mu_0}{4\pi} \int_{-\infty}^{\infty} \int_{-\infty}^{\infty} \int_{-\infty}^{\infty} j_{x1}(\alpha, \beta, \gamma) \cdot G(x_1, y_1, z, \alpha, \beta, \gamma) \cdot d\alpha \cdot d\beta \cdot d\gamma, \quad (8) \end{aligned}$$

$$\text{where } G(x_1, y_1, z, \alpha, \beta, \gamma) = \frac{\exp(-i \cdot k_1 \cdot R)}{R},$$

$$R = \sqrt{(x_1 - \alpha)^2 + (y_1 - \beta)^2 + (z - \gamma)^2}.$$

Analogous computed component  $A_{y1}$  allows to write a vector potential that determine electrical field intensity of radiated field:

$$\vec{E}_{rad}(x_1, y_1, z) = -\frac{i \cdot \omega}{k_1^2} \nabla(\nabla \cdot \vec{A}) - i \cdot \omega \cdot \vec{A}. \quad (9)$$

The radiated field in concrete coincides with the field, reflected from the metallic structure. For such interpretation on surface ( $z=-d/2$ ), the electromagnetic field, created by current, must have a flat wavefront. This idea of average boundary conditions was developed in [6]. The flat wavefront can be obtained for small cells, or for enough large distance between metallic structure and surface. In our case for  $d/2=0.2$  [m], the size of cell was obtained by compare computing for different  $a$  and  $b$ . For all case  $d_e=0.002$  [m]. For  $a=b=0.03$  [m] relative deviation over cell area do not exceed 0.7 %. For greater  $a$  and  $b$  deviation increases. Not significant deviation along the cell allows to present radiated field like flat wave sum of the

incident and reflected fields on boundary. To summarise, we must return to co-ordinate couple with incident wave:

$$\begin{cases} E_x = E_{x1} \cdot \cos(\varphi) - E_{y1} \cdot \sin(\varphi), \\ E_y = E_{x1} \cdot \sin(\varphi) + E_{y1} \cdot \cos(\varphi). \end{cases} \quad (10)$$

For  $\varphi = \pi/4$ ,  $a=b=0.03$  on surface  $E_x = -0.0191489 - j \cdot 0.0003534$ ,  $E_y = 0$  incidents to surface concrete – free room with transfer coefficient  $T = 1.42882 - j \cdot 0.00905353$ . We must add transferred field to the field, reflected from boundary free room–concrete  $R = -0.428815 + j \cdot 0.00905353$ . Now we have a corrected reflection coefficient  $R_{cor} = -0.456178 + j \cdot 0.0087219$ . This outcome doesn't depend from the angle between polarisation of incident wave and metallic structure geometry.

For non-square cells, the reflected field contains also other polarisation, that, in general, depends on angle  $\varphi$ . The calculating for  $a=0.02$  [m],  $b=0.03$  [m],  $\varphi = \pi/4$  gives  $R_{cor} = -0.461806 + j \cdot 0.00838485$  and reflected field with other polarisation  $E_{y,refl} = -0.00562761 + j \cdot 0.000337073$ .

The transfer coefficient of slab depends on penetration of a field via windows. We assume that the field intensity in windows is the same as in the middle of slab of concrete (without metallic structure). According to Huygens principle, this field creates wave that at enough great distance can be considered as a flat wave and transferred through boundary by simple conditions.

For calculating field, radiated from surface elements, it is handy to apply spherical system co-ordinates (Fig. 4), that, afterwards, can be transformed to Cartesian system.

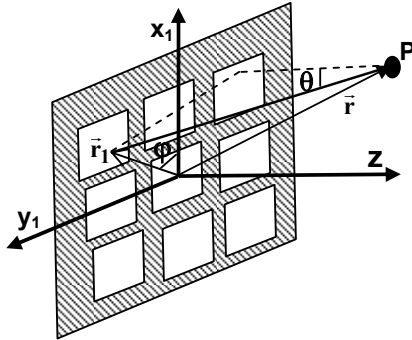

Fig. 4. Spherical system co-ordinates

In observation point P, the radiated field  $\vec{E}_P$  is determined by integrating results over all windows of structure. For field intensity component on surface  $E_{x1}^S$  and  $E_{y1}^S$ :

$$\begin{cases} \vec{E}_{Px1} = H \cdot \int_S [1 + \cos(\theta)] \cdot [\vec{e}_\theta \cdot \cos(\varphi) - \vec{e}_\varphi \cdot \sin(\varphi)] \cdot G(\vec{r}, \vec{r}_1) \cdot dS_1, \\ \vec{E}_{Py1} = J \cdot \int_S [1 + \cos(\theta)] \cdot [\vec{e}_\theta \cdot \sin(\varphi) + \vec{e}_\varphi \cdot \cos(\varphi)] \cdot G(\vec{r}, \vec{r}_1) \cdot dS_1, \end{cases} \quad (11)$$

where

$$G(\vec{r}, \vec{r}_1) = \frac{\exp(-i \cdot k_1 \cdot |\vec{r} - \vec{r}_1|)}{4\pi \cdot |\vec{r} - \vec{r}_1|},$$



$$H = i \cdot k_1 \cdot E_{x1}^S, \quad J = i \cdot k_1 \cdot E_{y1}^S.$$

The field intensities  $E_{x1}^S$  and  $E_{y1}^S$  are over region constant only for normal incident case.

We assume that the value of the flat wavefront, radiated from cell waves at co-ordinate  $z=d/2$ , was obtained accurately, because the field is created from a lot of radiated regions, located at enough great distance from surface.

The field intensity in windows  $E_x = 0.33358 + j \cdot 0.0027725$ . For calculating, this field was transformed to co-ordinate system, coupled with grid, and then, transformed to system, coupled with waves. For  $\varphi = \pi/4$ ,  $a=b=0.03$  on surface  $z=d/2$   $E_x = 0.162289 + j \cdot 0.00693169$ ,  $E_y = 0$ . This field incidents to surface concrete – free room and partially will be added to field, transmitted through slab, and partially reflected towards the lattice. The reflected part can cause multiple reflection between grid and surface, but, in our case, reflected field at metallic structure is  $E_{second} = 0.0398793 + j \cdot 0.000613665$ . This is approximately ten times smaller in magnitude than initial field in windows, and, being the first approximation we can take no notice of it. For transmission coefficient of slab  $T$ , the contribution is significant. Now  $T_{cor} = 0.231944 + j \cdot 0.00843481$ . This outcome doesn't depend on the angle between polarisation of incident wave and metallic structure geometry.

As distinct from radiation currents in frames, the non-square form of windows creates non cross polarisation, but changes only radiated field.

## Conclusion

This paper contains findings of authors, which concern reflection and transmission electromagnetic waves for dielectric slab with metallic structures inside. The metallic structure is periodic, with the relatively small period in comparison with wavelength. The necessity to limit a period is caused mainly by exigency to obtain an even field distribution at slab boundary. The idea of studied method is that the incident field creates current density in metallic frames of structure. These currents create reflected and transmitted waves. In addition the field in windows creates field behind grid in accordance to Huygens principle. The currents in frames and field intensity in windows are set approximately.

Current radiated fields give little than 10% deviation for slab reflection coefficient for our selected geometry. It doesn't depend on angle between polarisation of incident wave and frames. For non-square cells only, the reflected field contains small different polarisation field.

The field, radiated by field distribution in windows, significantly changes transmission coefficient but, non-square form of windows doesn't create cross polarisation.

This work has been partly supported by the European Social Fund within the National Programme "Support for the carrying out doctoral study programm's and post-

doctoral researches” project “Support for the development of doctoral studies at Riga Technical University”.

## References

1. **Ziemelis J.** The Models of Walls for Ray Tracing Indoor Simulation // *Electronics and Electrical Engineering*, ISSN 1392–1215. – Kaunas: Technologija, 2001. – No 4(32). – P.20–23.
2. **D'Amore M., Sarto M. S.** Theoretical and Experimental Characterization of the EMP–Interaction with Composite Metallic Enclosures // *IEEE Transactions on Electromagnetic Compatibility*, 2000. – V. 42, No. 2. – P. 152–163.
3. **Richalot E., Bonilla M., Wong Man–Fai.** Electromagnetic Propagation into Reinforced–Concrete Walls // *IEEE Transactions on Microwave Theory and Techniques*, 2000. – V. 48, No.3. – P. 357–366.
4. **Paknys R.** Reflection and Transmission by Reinforced Concrete – Numerical and Asymptotic Analysis // *IEEE Transactions on Antennas and Propagation*, 2003. – V. 51, No.10. – P. 2852–2861.
5. **Poljanin A.D.** Handbook for linear equations of mathematical physics. (in russian). – Moscow: Fizmatlit, 2001. – 575 p.
6. **Kontorovich M. I., Astrahan M. I., Akimov V. P.** Electrodynamics of grid structures. (in russian). – Moscow: Radio i cvjaz, 1987. –134 p.

Pateikta spaudai 2005 06 01

### **J. Ziemelis, T. Solovjova. Plokščiosios elektromagnetinės bangos atsispindėjimas nuo dielektriko sluoksnio su įtaisyta metaline gardele // Elektronika ir elektrotechnika. – Kaunas: Technologija, 2005. – Nr. 6(62). – P. 9–12.**

Pateikti atspindėjimo ir dielektrinio sluoksnio su vidine metalo struktūra elektromagnetinių bangų tyrimai. Parinkta periodinė metalo struktūra, kurio periodas mažas palyginti su bangos ilgiu. Tyrimams naudojamas elektrinis laukas, sukuriama struktūros metalinėse gardelėse, kuriame susidaro atsispindėjusioji ir perėjusioji banga. Be to, lauko susidarymas struktūros languose pagal Giuigeno principą sukuria lauką už gardelės. Srovės metalinėse gardelėse tankis ir lauko išsisklaidymas ant langų yra nustatyti apytiksliai. Srovės sukurtas atsispindėjęs laukas struktūros geometrijoje pakeičia atsispindėjimo koeficientą mažiau nei 10 %, tačiau lauko sklaida languose gerokai padidino perėjimo koeficientą. Il. 4, bibl. 6 (anglų kalba; santraukos lietuvių, anglų ir rusų k.).

### **J. Ziemelis, T. Solovjova. The Reflection of Plane Electromagnetic Wave from Dielectric Slab with Metallic Lattice Inside // Electronics and Electrical Engineering.– Kaunas: Technologija, 2005. – No. 6(62). – P. 9–12.**

This paper contains findings of authors, which concern reflection and transmission electromagnetic waves for dielectric slab with metallic structures inside. The metallic structure is periodic, with the relatively small period in comparison with wavelength. The idea of studied method is that the incident field creates current density in metallic frames of structure. These currents create reflected and transmitted waves. In addition the field in windows creates field behind grid in accordance to Huygens principle. The currents in frames and field intensity in windows are set approximately. Current radiated fields give little than 10% deviation for slab reflection coefficient for our selected geometry. The field, radiated by field distribution in windows, significantly changes transmission coefficient. Ill. 4, bibl. 6 (in English; summaries in Lithuanian, English and Russian).

### **Ю. Зиемелис, Т. Соловьёва. Отражение плоской электромагнитной волны от слоя диэлектрика со встроенной металлической решёткой // Электроника и электротехника. – Каунас: Технолгия, 2005. – № 6(62). – С. 9–12.**

Работа содержит исследования отражения и прохождения электромагнитных волн для диэлектрического слоя с внутренней металлической структурой. Металлическая структура выбрана периодической, с периодом малым по сравнению с длиной волны. Для исследований используется поле, созданное током в металлических рамках структуры, который создаёт отражённую и прошедшую волны. Кроме того, распределение поля в окнах структуры согласно принципу Гюйгенса создаёт поле за решёткой. Плотность тока в металлических рамках и распределение поля в окнах определены приближенно. Созданное токами отражённое поле для выбранной в работе геометрии структуры изменяет коэффициент отражения менее чем на 10 %, но распределение поля в окнах существенно увеличило коэффициент прохождения. Ил. 4, библи. 6 (на английском языке; рефераты на литовском, английском и русском яз.).

DOI: 10.5755/j02.eie.10482