

Computer Modelling of the Starting Processes of Induction Motor

J. Karaliūnienė, L. Krikštaponis, D. Lukošienė

*Department of Electrical Engineering, Vilnius Technical College,
 Olandu st. 16, LT-01100 Vilnius, Lithuania, tel.: +370 261 03 40, e-mail: dalia.lukosiene@vtk.lt*

Introduction

Contemporary computer hardware and software technology enables to simulate any regime of work of induction motor and to obtain its characteristics. Therefore science articles are recently being published, examining regimes of work of induction motor and drives, and transient processes, using the special models substantiated by digital methods and iterative calculations.

Article [1] examines physical processes of the salient pole electrical machines of alternating current, taking into account the discrete arrangement of windings, and also the primary and secondary asymmetry of such machines. It is shown that in such machines the higher harmonics of new frequencies are generated, since the parameters of inductive machines change during time. Therefore machines in the mathematical model occurs elementary component both with the positive and with the negative frequencies. The author asserts that in this case the sign of frequency shows the harmonics of magnetomotive force, which creates the current of rectilinear and reverse priority, direction the rotation.

Problems of control of the frequency of three-phase induction motors are examined in article [2]. The obtained diagrams show that, having correctly selected the structure of system control, it is possible to obtain the transient processes of drive which are close to being optimum.

The starting procedure of induction motor, with estimation of change of inductive reactances of equivalent circuit, is examined in article [3]. Software bundle of the company ANSYS is used for simulation of magnetic field and transient launch procedures of engine.

Conditions of work and feed circuit effect on characteristics of the functioning of induction motors in deep bore holes are examined in article [4]. Calculation algorithm and computer software is comprised by taking into account the change in the parameters of temperature of bore hole, pressure and feed cable. In scientific works [5,6] the electromagnetic processes of inverter and vector control of induction motors in the real time are examined, using the software bundle Matlab/Simulink.

The purpose of this work is to construct a computer model of the starting processes of induction motor and to present the results of a study.

Basic equations and their transformation

For the computer simulation we select the system connected with the fixed stator $\alpha, \beta, 0$. In this case the differential vector equations of induction motor are as follows:

$$\begin{cases} \mathbf{u}_s = R_s \mathbf{i}_s + L_s \frac{d\mathbf{i}_s}{dt} + M \frac{d\mathbf{i}_r}{dt}, \\ \mathbf{u}_r = R_r \mathbf{i}_r + L_r \frac{d\mathbf{i}_r}{dt} + M \frac{d\mathbf{i}_s}{dt} - j\omega(M\mathbf{i}_s + L_r \mathbf{i}_r), \\ M_{el} = \frac{3}{2} pM |\mathbf{i}_s \times \mathbf{i}_r|, \end{cases} \quad (1)$$

where $\mathbf{u}_s, \mathbf{i}_s$ – vector of voltage and current of stator; $\mathbf{u}_r, \mathbf{i}_r$ – vector of voltage and current of rotor; R_s, R_r – active stator winding resistance and rotor winding resistance respectively; L_s, L_r – inductance of the windings of stator – rotor unit; M – mutual inductance of windings; ω – rotor angular velocity; M_{el} – motor electromagnetic torque; p – pole – pairs of motor; $j = \sqrt{-1}$.

It should be noted that the system (1) contains complex coefficients, which have to be eliminated before simulations. The best way to do it is to find the projections of all vectors on the axes of engine α and β , for example:

$\mathbf{u}_s = u_{s\alpha} + ju_{s\beta}$ etc. By splitting all vectors in the equation system, this system is changed so:

$$\begin{cases} u_{s\alpha} = R_s i_{s\alpha} + L_s \frac{di_{s\alpha}}{dt} + M \frac{di_{r\alpha}}{dt}, \\ u_{s\beta} = R_s i_{s\beta} + L_s \frac{di_{s\beta}}{dt} + M \frac{di_{r\beta}}{dt}, \\ u_{r\alpha} = R_r i_{r\alpha} + L_r \frac{di_{r\alpha}}{dt} + M \frac{di_{s\alpha}}{dt} + \omega(M i_{s\beta} + L_r i_{r\beta}), \\ u_{r\beta} = R_r i_{r\beta} + L_r \frac{di_{r\beta}}{dt} + M \frac{di_{s\beta}}{dt} - \omega(M i_{s\alpha} + L_r i_{r\alpha}), \\ M_{el} = \frac{3}{2} pM (i_{s\beta} i_{r\alpha} - i_{s\alpha} i_{r\beta}). \end{cases} \quad (2)$$

Equations of simulation system (2) are being modeled with the fundamental equation of the drive:

$$J_{red} \frac{d\omega}{dt} = M_{el} - \Sigma M_{rez}; \quad (3)$$

where J_{red} – the reduced moment of the inertia of rotor;
 ΣM_{rez} – the sum of the acting moments of resistances in the drive.

Equations (2) and (3) enable all delivery functions, which are necessary for creating the computer model. But first, all equations are written in the operator form:

$$\begin{cases} u_{s\alpha} = R_s i_{s\alpha} + L_s i_{s\alpha} s + M i_{r\alpha} s, \\ u_{s\beta} = R_s i_{s\beta} + L_s i_{s\beta} s + M i_{r\beta} s, \\ u_{r\alpha} = R_r i_{r\alpha} + L_r i_{r\alpha} s + M i_{s\alpha} s + \omega (M i_{s\beta} + L_r i_{r\beta}), \\ u_{r\beta} = R_r i_{r\beta} + L_r i_{r\beta} s + M i_{s\beta} s - \omega (M i_{s\alpha} + L_r i_{r\alpha}), \\ M_{el} = \frac{3}{2} p M (i_{s\beta} i_{r\alpha} - i_{s\alpha} i_{r\beta}), \\ J_{red} \omega s = M_{el} - \Sigma M_{rez}, \end{cases} \quad (4)$$

where $s = \frac{d}{dt}$ – the operator Laplace.

Dependence between input and output variables of stator chain is as follows:

$$\begin{cases} i_{s\alpha} = \frac{u_{s\alpha} - M s i_{r\alpha}}{R_s + L_s s}, \\ i_{s\beta} = \frac{u_{s\beta} - M s i_{r\beta}}{R_s + L_s s}. \end{cases} \quad (5)$$

Delivery function describing rotor circuit has more input variables. Output variables are components of the rotor current:

$$\begin{cases} i_{r\alpha} = \frac{u_{r\alpha} - \omega (M i_{s\beta} + L_r i_{r\beta}) - M s i_{s\alpha}}{R_r + L_r s}, \\ i_{r\beta} = \frac{u_{r\beta} + \omega (M i_{s\alpha} + L_r i_{r\alpha}) - M s i_{s\beta}}{R_r + L_r s}. \end{cases} \quad (6)$$

Equations (5) and (6) indicate that in order to compose the block diagram of the motor model, basic delivery functions are aperiodic inertia chains.

Structure of the model of starting processes

The computer model of the starting procedures of motor and its block diagram are constructed by applying system of equations (4) – (6). Software bundle Matlab/Simulink is used for this purpose. The block diagram of the model of the cage rotor is shown in Fig. 1.

In Simulink environment, after connecting separate models into one, we obtain the computer model of the process of motor starting, the overall structure diagram of which is shown in Fig. 2. This model of induction motor which is suitable for investigating the transient processes of the stator and rotor currents, speed and electromagnetic torque. After a simple modification of block diagram we can simulate magnetic fluxes.

For the simulation of starting procedures into the programs compulsorily are assigned the parameters of circuit of the substitution of concrete motor, the method of solving the equations, accuracy, step of integration and etc.

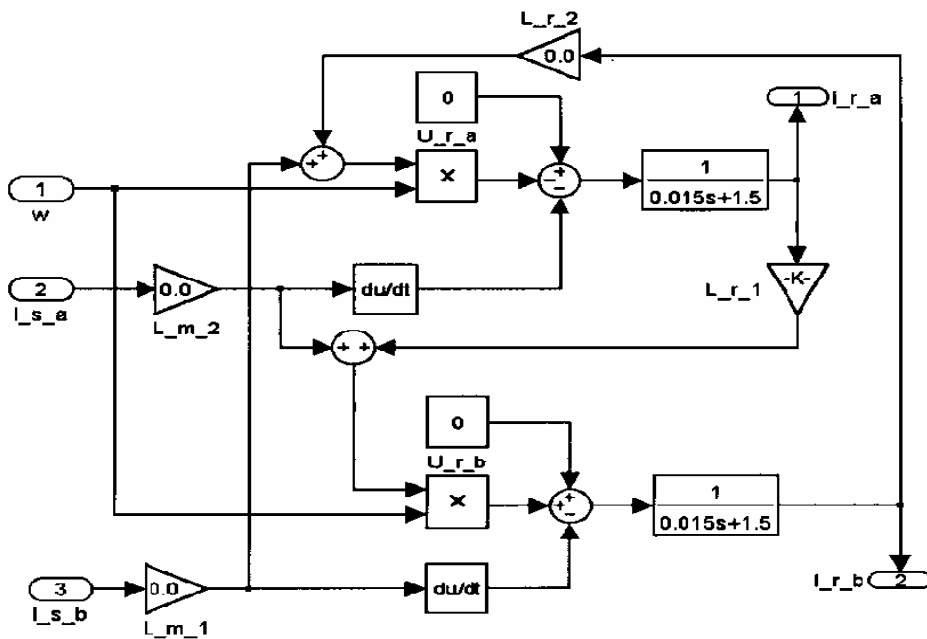

Fig. 1. Block diagram of the model of squirrel-cage rotor of induction motor

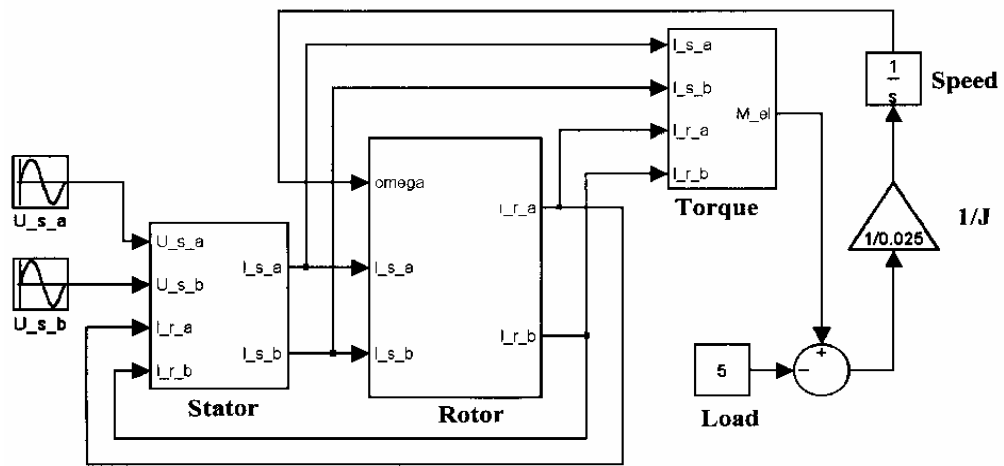

Fig. 2. Structure diagram of the model of starting processes of induction motor

Results of simulation

For investigating the starting procedures were introduced such parameters of equivalent circuit of induction motor with cage rotor: $R_1 = 6 \Omega$; $X'_1 = 0,4 \Omega$; $X_{12} = 4 \Omega$; $R'_2 = 12,5 \Omega$; $X'_2 = 0,6 \Omega$; $J_{red} = 0,05 \text{ kgm}^2$; $U_1 = \sqrt{2} \cdot 220 \text{ V}$. Fig.3 shows the transient process of the speed with the direct starting of idle motor. The transient processes of electromagnetic torque they are indicated in Fig. 4: a) – motor starting at the idling; b) – static load moment is $M_{st} = 5 \text{ Nm}$. Changing the current of rotor with the starting is shown in Fig. 5.

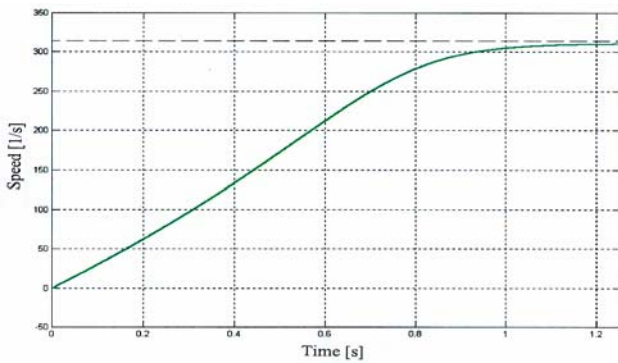
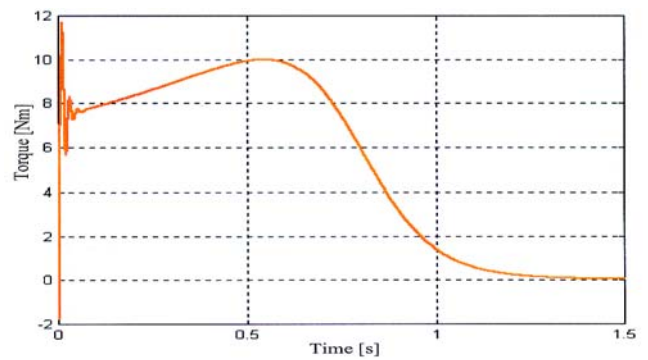
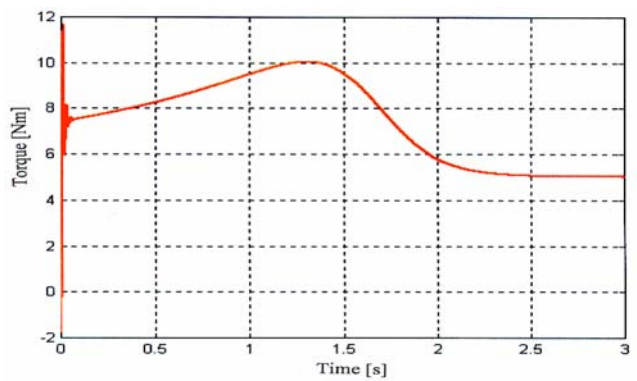

Fig. 3. Transient process of the speed with the direct starting of idle motor



a)



b)

Fig. 4. Transient processes of electromagnetic torque: a) – motor starting at the idling; b) – static load moment is $M_{st} = 5 \text{ Nm}$

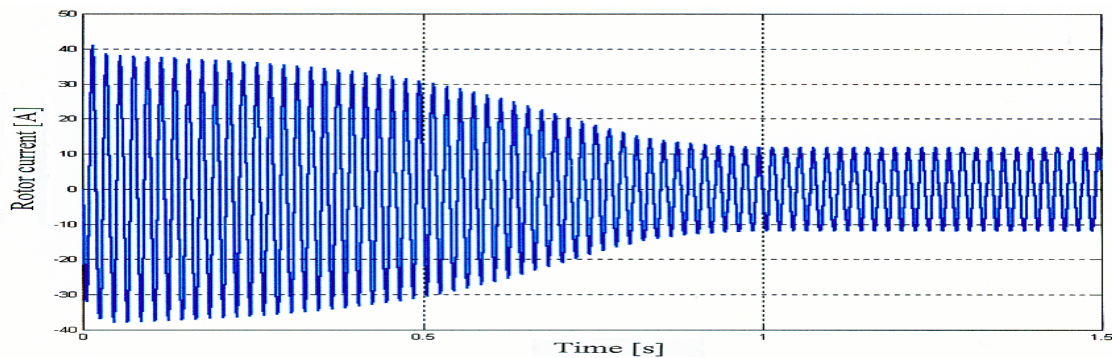

Fig. 5. Changing the starting current of rotor

Conclusions

1. It is created the new computer model of the starting processes of the induction motor, under basis of which are undertaken differential equations of the transformed coordinates of motor. This model is created to system Matlab/Simulink, which widely they adapt in the scientific and engineering practice.
2. The created model is universal, because it is possible to simulate direct starting processes of induction motors with cage rotors and phase – wound rotors and also the transient processes of rheostat start up. Simulating the starting processes of the loaded motor, it is possible to conduct the loads of the different types: active, reactive, ventilator, etc.
3. Results of simulation it shows that to the processes of motor starting are characteristic the jumps of currents and electromagnetic torque in the beginning of starting and decrease at the end of the starting.

References

1. **Ефименко Е. И.** Физические процессы в явнотолковых машинах переменного тока и их аналитическое

описание с учетом дискретности обмоток // Электричество. – 2001. – № 4. – С. 27 – 36.

2. **Kazmierkowski M. P.** Control Strategies for PWM Rectifier/Inverted – Fed Induction Motor // Proc. of 9 – th Int. Conf. On Power Electronics and Motion Control. EPE – PEMS. – Košice, Slovak Republic, 2000. – Vol. 1. – P. 69 – 78.
3. **Кобзистый С. Ю., Кононенко К. Е., Тон Д. А.** Учет изменения индуктивных параметров схемы замещения при пуске асинхронного двигателя // Известия вузов. Электромеханика. – 2004. – № 3. – С. 35 – 38.
4. **Gečys S.** An Influence of Operating Medium Temperature Change on Characteristics of Electric Motor for Borehole Investigation Devices // Electronics and Electrical Engineering. – Kaunas: Technologija, 2006. – Nr. 1 (65). – P. 64 – 67.
5. **Abid M., Ramdani Y., Meroufel A. K.** Speed Sliding Mode Control of Sensorless Induction Machine // Journal of Electrical Engineering. – Slovak Centre of IEE, 2006. – Vol. 57, № 1. – P. 47 – 51.
6. **El – Kholy E. E., Kennel R., El – rafaei A., El – Latif S. A.** Robust Space – Vector Current Control for Induction Motor Drives // Journal of Electrical Engineering. – Slovak Centre of IEE, 2006. – Vol. 57, № 2. – P.61 – 68.

Submitted for publication 2006 12 11

J. Karaliūnienė, L. Krikštaponis, D. Lukošienė. Computer Modelling of the Starting Processes of Induction Motor // Electronics and Electrical Engineering. – Kaunas: Technologija, 2007. – No. 3(75). – P. 41–44.

The computer simulation of the starting processes of an induction motor is discussed. Differential equations of motor are presented. They are written on an axis α, β, o of coordinate system, connected with the fixed stator. The computer model of starting procedures is constructed in the environment of Matlab/Simulink, which is widely used in scientific and engineering practice. In order to create a model, the principle of objective programming is used. With created model it is possible to simulate direct starting processes of induction motor and the transient processes of rheostat start up. The model and processes of resistance starting are presented. The results of simulation shows that in the beginning of transient process appear the shock of starting currents and because of interaction of shock currents shock components of electromagnetic torque are created. Ill. 5, bibl.6 (in English; summaries in English, Russian and Lithuanian).

Ю. Каралюнене, Л. Крикштапонис, Д. Лукошене. Компьютерное моделирование процессов пуска асинхронного мотора // Электроника и электротехника. – Каунас: Технология, 2007. – № 3(75). – С. 41–44.

Исследуются вопросы компьютерного моделирования пусковых режимов асинхронного мотора. Дифференциальные уравнения мотора записаны в системе координат α, β, o , связанной с неподвижным статором. Компьютерная модель процессов пуска составлена в системе Matlab/Simulink, которая широко применяется в научной и инженерной практике. При создании модели использован принцип объектного программирования. Представленная модель пригодна для исследования переходных процессов прямого пуска мотора с короткозамкнутым и фазным ротором, а также процессов реостатного пуска. Результаты моделирования показывают, что в начале переходного процесса появляются ударные пусковые токи, из-за взаимодействия которых создаются ударные составляющие электромагнитного момента. Ил. 5, библи. 6 (на английском языке; рефераты на английском, русском и литовском яз.)

J. Karaliūnienė, L. Krikštaponis, D. Lukošienė. Asinchroninio variklio paleidimo procesų kompiuterinis modeliavimas // Elektronika ir elektrotechnika. – Kaunas: Technologija, 2007. – Nr. 3(75). – P. 41–44.

Nagrinėjami asinchroninio variklio paleidimo procesų kompiuterinio modeliavimo klausimai. Variklio diferencialinės lygtys užrašytos su nejudančiu statoriumi susietoje koordinacijų sistemoje α, β, o . Paleidimo procesų modelis sudarytas modernioje Matlab/Simulink sistemoje, kuri plačiai taikoma mokslinėje bei inžinerinėje praktikoje. Modeliui sudaryti panaudotas objektinio programavimo principas. Pateiktas modelis tinka variklį su narveliniu ir faziniu rotoriumi tiesioginio paleidimo, taip pat ir reostatinio paleidimo pereinamiesiems procesams tirti. Gauti modeliavimo rezultatai rodo, kad pačioje pereinamojo proceso pradžioje atsiranda smūginės paleidimo srovės, dėl kurių sąveikos sukuriamos ir elektromagnetinio momento smūginės dedamosios. Šiuos procesus sąlygoja energijos mainai tarp variklio ir tinklo. Il. 5, bibl. 6 (anglų kalba; santraukos anglų, rusų ir lietuvių k.).

