

## **New Approach for Evaluation of Electromagnetic Properties of Three-Phase Windings**

**J. Bukšnaitis**

*Department of Agroenergetics, Lithuanian University of Agriculture,  
Akademija, LT – 53361 Kaunas distr., Lithuania, tel.: +370 7 397529, e-mail: Juozas.Buksnaitis@lzuu.lt*

### **Introduction**

As it is known, three-phase windings of alternating-current electric machines have many construction types and different parameters. For this reason electromagnetic properties of such windings, their laying conditions, work and material expenses for their manufacture, advantages and disadvantages caused by that are very different. This has to be considered when selecting the type of three-phase winding for designed alternating-current electric machine.

Technological workability of manufacture of three-phase windings, work and material consumption for their manufacture is very important factors, thus over a long experience in the field of manufacture and exploitation of electric machines they are quite well analyzed. Nevertheless energetic indexes of alternating-current electric machines and work quality is mostly determined by electromagnetic properties of these windings. Mathematical analysis of rotating magnetomotive forces created by three-phase windings and of magnetomotive forces induced in them is still incomplete, there is no clear evaluation and comparison of their electromagnetic properties according to some certain indexes [1-4]. After determining winding factors of fundamental and higher harmonics of magnetomotive or electromotive force (this is the basis of research of three-phase winding electromagnetic properties, indicated in many references presented here), the quality of these windings is evaluated not completely, since these factors show only relative amplitude values of respective harmonics of magnetomotive or electromotive force in respect of corresponding harmonic amplitudes of concentrated single-layer three-phase windings, but do not indicate relational relative values of magnetomotive or electromotive force harmonics of considered three phase windings. According to winding factors, which usually comprise a polysemous system, it is also difficult to compare several types of three-phase windings and to select the most optimal from them according to electromagnetic properties. Furthermore, it is impossible to determine factors of even harmonics of three-phase windings, for example, single-layer chain windings, two layer former fractional windings,

which also create even harmonics of magnetomotive force, since concentrated three-phase windings does not create these harmonics.

The aim of this paper is to substantiate theoretically unambiguous evaluation of electromagnetic properties of three-phase windings, on the basis of which it would be easy enough to compare different type windings and to distinguish the optimal one.

### **Theoretical Basis for Evaluation of Electromagnetic Properties of Three-Phase Windings**

All types of three-phase windings of alternating current electric motors, in which the process of transformation of electrical energy into the energy of magnetic field takes place, create rotating magnetomotive forces which alternate in space according to non-sinusoidal law. These non-sinusoidal periodic functions move over time in one or another direction along space axis (in the air gap) with some certain velocity and periodically change their shape (more or less). The bigger influence of higher space harmonics of magnetomotive force, i.e. the higher their amplitude values, the bigger difference of rotating magnetomotive force curve compare to sinusoidal function. When characterizing the non-sinusoidality of this space function using respective factors, qualitative evaluation of the three-phase winding according to electromagnetic properties would be received also, since the shape of rotating magnetomotive force mainly depends on it. Certainly, the numerical value of this factor should not depend on time, and its optimal value should be equal to one.

As it is known, no sinusoidal time functions are characterized using amplitude, shape, distortion and other factors [5]. But in order to characterize space no sinusoidal functions (curves of rotating magnetomotive forces) the amplitude  $k_a$  or shape  $k_f$  factors are not suitable, since their shape periodically changes more or less over time, and in addition, numerical values of these factors in case of sinusoidal (optimal) time functions, are bigger than one. For electromagnetic evaluation of three-phase windings the distortion factor  $k_i$  can be partly used, which in no

sinusoidal time functions is equal to ratio of fundamental harmonic effective value and no sinusoidal magnitude effective value [5]. Furthermore, this factor for sinusoidal function is equal to one.

Distortion factor  $k_i$  of space no sinusoidal functions could be defined using ratio of fundamental magnetomotive force space harmonic maximal value with equivalent maximal value of no sinusoidal magnetomotive force function, or ratio of magnetomotive force fundamental harmonic relative value  $f_p = 1$ , which is equated to one, and all no sinusoidal magnetomotive force function equivalent relative value  $f_\Sigma$ . Considering this the no sinusoidal space function (magnetomotive force) distortion factor expression is received:

$$k_i = \frac{F_{mp}}{\sqrt{\sum_{v=1}^{\infty} F_{mv}^2 + \sum_{v=2}^{\infty} F_{mv''}^2}} = \frac{1}{\sqrt{\sum_{v=1}^{\infty} f_v^2}}; \quad (1)$$

where  $F_{mp}$  – amplitude value of fundamental harmonic of rotating magnetomotive force;

$$F_{mp} = \frac{4}{\pi} \sum_{i=1}^k F_i \sin \frac{\alpha_i}{2} \cos \gamma_i; \quad (2)$$

$F_{mv'}$  – amplitude value of  $v'$ -th odd harmonic of rotating magnetomotive force;

$$F_{mv'} = \frac{4}{\pi v'} \sum_{i=1}^k F_i \sin v' \frac{\alpha_i}{2} \cos v' \gamma_i; \quad (3)$$

$F_{mv''}$  – amplitude value of  $v''$ -th even harmonic of rotating magnetomotive force;

$$F_{mv''} = \frac{4}{\pi v''} \sum_{i=1}^k F_i \sin v'' \frac{\alpha_i}{2} \sin v'' \gamma_i; \quad (4)$$

In (1-4)  $k$  – number of rectangles, forming the half-period of stair-shape magnetomotive force curve (Fig. 1);  $F_i$  – real or conditional height of  $i$ -th rectangle of half-period of stair-shape magnetomotive force (Fig. 1);  $\alpha_i$  – width of  $i$ -th rectangle of stair-shape magnetomotive force, expressed in degrees of period of fundamental harmonic (Fig. 1);  $\gamma_i$  – asymmetry of  $i$ -th rectangle of stair-shape magnetomotive force half-period in respect of selected axis, expressed in degrees of period of fundamental harmonic (Fig. 1);  $v'$  – index of odd space harmonic;  $v''$  – index of even space harmonic. Relative value  $f_v$  of any  $v$ -th harmonic of rotating magnetomotive force is

$$f_v = \frac{F_{mv}}{F_{mp}}. \quad (5)$$

Graphical image of rotating magnetomotive force wave of asymmetrical distributed three-phase windings at time moment  $t = 0$ , which in general case consists of  $k$

rectangles of different heights and widths and which is symmetrical only with respect to the beginning of its half-periods, in general case can be represented as in Fig. 1.

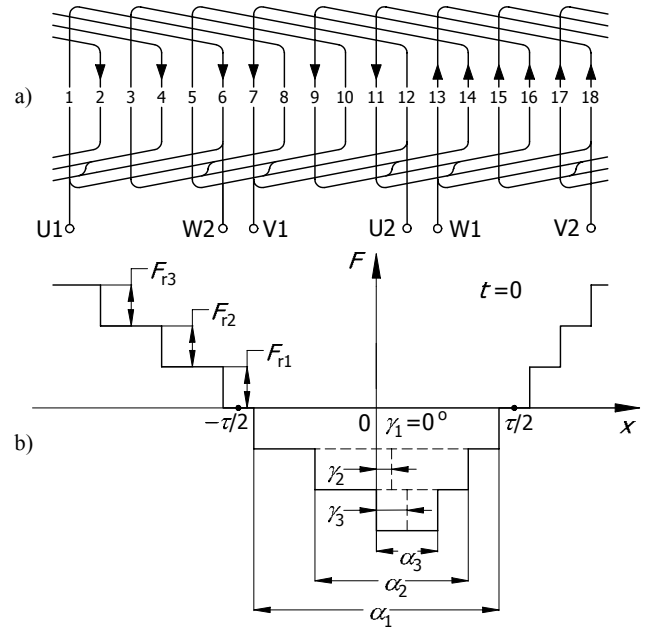

**Fig. 1** Space distribution of stair-step shaped rotating magnetomotive force of one of asymmetrical distributed three-phase windings (a), which is symmetrical only with respect to the beginning of its half-periods, at particular moment of time (b)

Three-phase winding would be optimal from electromagnetic considerations if distortion factor  $k_i$  of magnetomotive force created by it would be equal to one.

Since higher harmonics of magnetomotive force have a negative influence on operation of alternating-current electric machines, therefore these harmonics and their absolute values can be considered as negative. All these negative relative values can be joined into one equivalent value, which will be equal to square root of sum of squares of absolute relative values of magnetomotive force higher harmonics [6]. On the basis of these assumptions, electromagnetical properties of three-phase windings can also be evaluated using electromagnetic efficiency factor, which is expressed in the following way:

$$k_{ef} = 1 - \sqrt{\sum_{v=1}^{\infty} f_v - 1}; \quad (6)$$

where  $f_v$  – relative value of rotating magnetomotive force  $v$ -th harmonic, found from (5) equation.

This factor shows, what part of fundamental harmonic of relative rotating magnetomotive force remains after the negative influence of higher harmonics of its rotating magnetomotive force have been compensated. From electromagnetic considerations the three-phase winding would be also optimal, if  $k_{ef}$  would be equal to one. This means, that the more this factor, calculated for real three-phase winding, is close to one, the higher is the quality of this winding from electromagnetic point of view.

## Evaluation of Electromagnetic Properties of Some Three-Phase Windings

We will consider several three-phase windings and determine distortion and electromagnetic efficiency factors of magnetomotive force created by them according to equations (1), (6). Single-layer concentrated (Fig. 2), chain (Fig. 3), former and concentric (Fig. 4), two-layer former no fractional (Fig. 5) and two-layer former fractional (Fig. 6) three-phase windings were selected for investigation. Main parameters of investigated windings are presented in Table 1.

**Table 1.** Parameters of investigated three-phase windings

Parameters of windings	Winding type according to numbers of presented figures				
	1	2	3	4	5
Number of phases ( $m$ )	3	3	3	3	3
Number of slots ( $Z$ )	24	12	24	12	12
Number of poles ( $2p$ )	8	2	4	2	8
Number of sections in the group ( $q$ )	1	2	2	2	1/2
Pole pitch ( $\tau$ )	3	6	6	6	3/2
Winding span ( $y$ )	3	5	6	5	2
Slot pitch in el. degrees ( $\varphi$ )	$60^\circ$	$30^\circ$	$30^\circ$	$30^\circ$	$120^\circ$

Assume, that the relative number of turns of the group of considered three-phase winding sections is  $N_g = 1$ , then the relative number of turns of one section of concentrated winding is  $N_s = 1$ , for single-layer chain, former and concentric –  $N_s = 0,5$ , two-layer former no fractional –  $N_s = 0,25$  and two-layer former fractional –  $N_s = 1$ .

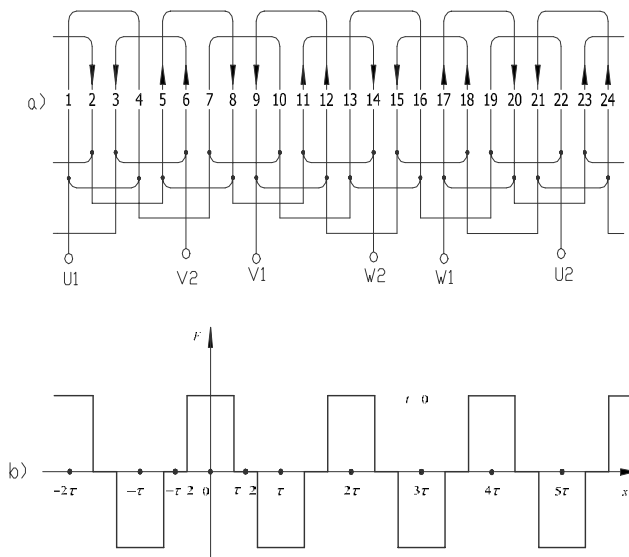

**Fig. 2.** Connection scheme of eight-pole concentrated three-phase windings (a) and the distribution of its rotating magnetomotive force in time moment  $t = 0$  (b)

Relative maximal electric current values in these windings  $I_{mU} = I_{mV} = I_{mW} = 1$ . Then the relative

momentary electric current magnitudes in phase windings in the defined moment of time  $t = 0$  are equal:

$$\begin{cases} i_U = \sin \omega t = \sin 0^\circ = 0; \\ i_V = \sin(\omega t - 120^\circ) = \sin(-120^\circ) = -0,866; \\ i_W = \sin(\omega t - 240^\circ) = \sin(-240^\circ) = 0,866. \end{cases} \quad (7)$$

Conditional changes of magnetomotive force in slots are determined on the basis of analyzed three-phase winding connection schemes, their relative number of turns of one section, and also relative electric current values of phase windings in time moment  $t = 0$ . They are presented in Table 2.

**Table 2.** Conditional changes of magnetomotive force in slots of analyzed three-phase windings in time moment  $t = 0$

No. of the slot	Winding type according to the number of presented figures				
	1	2	3	4	5
1	0	0	0	0	0,866
2	-0,866	-0,433	0	-0,216	-1,732
3	-0,866	0	-0,433	-0,433	0,866
4	0	-0,433	-0,433	-0,433	0,866
5	0,866	-0,433	-0,433	-0,433	-1,732
6	0,866	0	-0,433	-0,216	0,866
7	0	-0,433	0	0	0,866
8	-0,866	0	0	0,216	-1,732
9	-0,866	0,433	0,433	0,433	0,866
10	0	0,433	0,433	0,433	0,866
11	0,866	0,433	0,433	0,433	-1,732
12	0,866	0,433	0,433	0,216	0,866

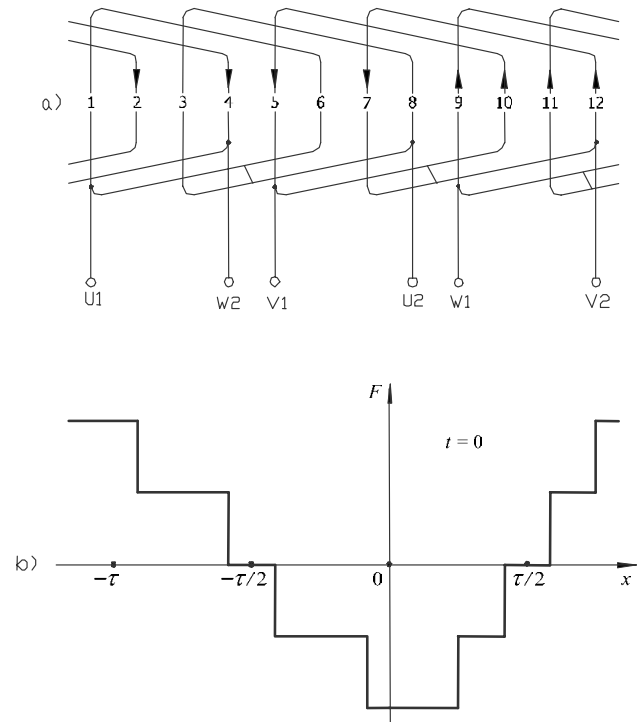

**Fig. 3.** Connection scheme of two-pole chain three-phase winding (a) and the distribution of its rotating magnetomotive force in time moment  $t = 0$  (b)

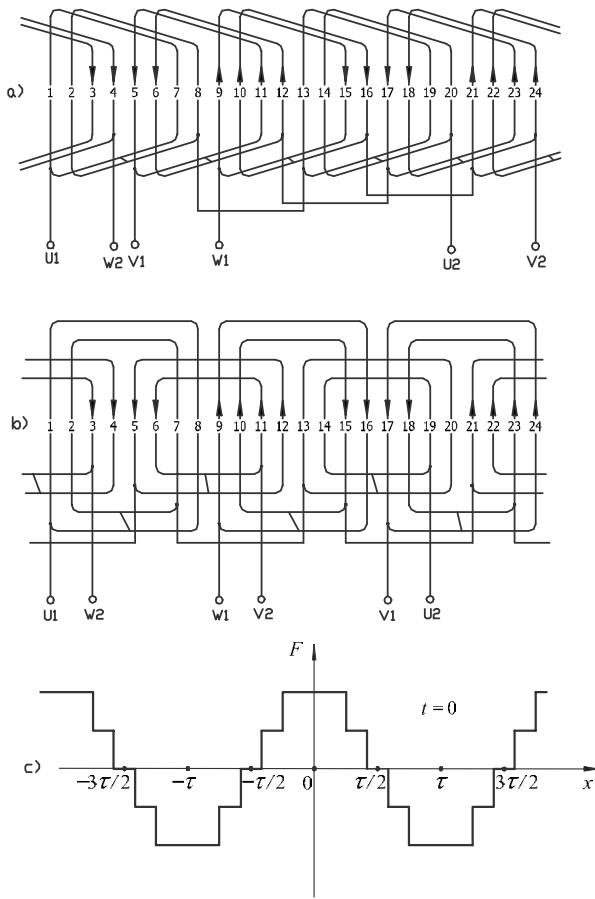

**Fig. 4.** Connection schemes of four-pole single-layer former (a) and concentric (b) three-phase windings and the distribution of their rotating magnetomotive force in time moment  $t = 0$  (c)

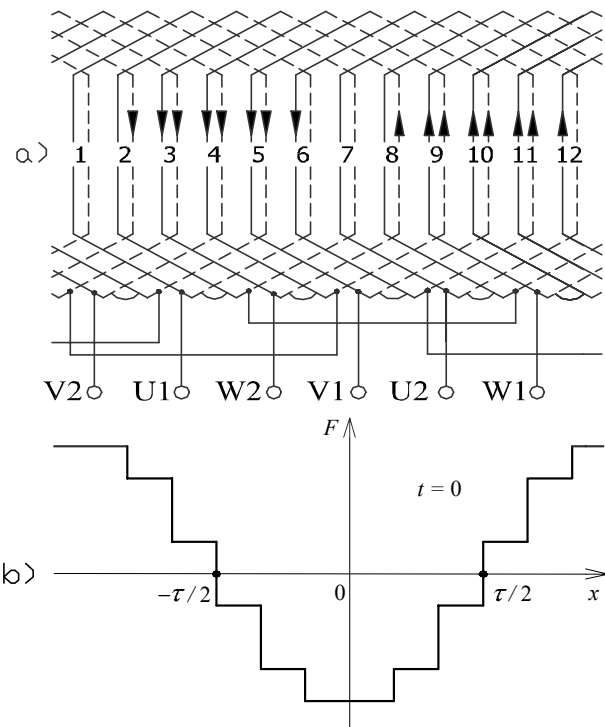

**Fig. 5.** Connection scheme of two-pole former no fractional three-phase winding (a) and the distribution of its rotating magnetomotive force in time moment  $t = 0$  (b)

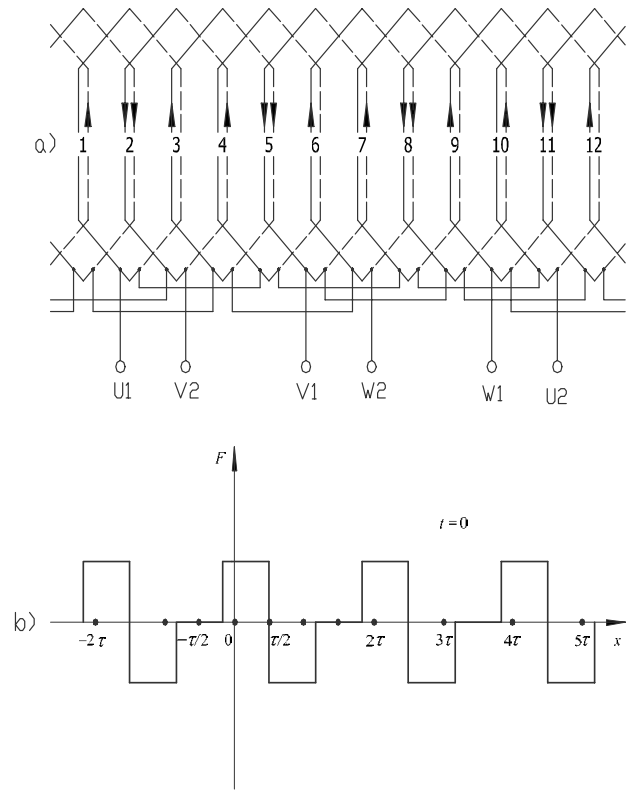

**Fig. 6.** Connection scheme of eight-pole two-layer former fractional three-phase winding (a) and the distribution of its magnetomotive force in time moment  $t = 0$  (b)

According to the results presented in Table 2 the rotating magnetomotive force stair-shape space distributions of analyzed three-phase windings in the selected moment of time are formed (Fig. 1 – 5, b). In order to perform harmonic analysis, the parameters of no sinusoidal periodic magnetomotive force stair-shape curve half-periods, divided into horizontal rectangles, received from Fig. 1–5, b, are presented in Table 3 [6].

**Table 3.** Parameters of magnetomotive force curve half-periods of analyzed three-phase windings in time moment  $t = 0$

Parameters of half-period	Winding type according to the numbers of presented figures				
	1	2	3	4	5
$k$	1	2	2	3	1
$F_1$	0,866	-0,433	0,433	-0,216	0,866
$F_2$	-	-0,433	0,433	-0,433	-
$F_3$	-	-	-	-0,216	-
$\alpha_1$	$120^\circ$	$150^\circ$	$150^\circ$	$180^\circ$	$120^\circ$
$\alpha_2$	-	$60^\circ$	$90^\circ$	$120^\circ$	-
$\alpha_3$	-	-	-	$60^\circ$	-
$\gamma_1$	$0^\circ$	$0^\circ$	$0^\circ$	$0^\circ$	$-30^\circ$
$\gamma_2$	-	$-15^\circ$	$0^\circ$	$0^\circ$	-
$\gamma_3$	-	-	-	$0^\circ$	-

The harmonic analysis of created stair-shape magnetomotive force curves of considered three-phase windings was performed using expressions (3), (4) and data from Table 3, [6]. The results of this analysis are presented in Table 4.

**Table 4.** The results of harmonic analysis of magnetomotive force curves of considered three-phase windings

Harmonic index	Winding type according to the numbers of presented figures				
	1	2	3	4	5
1	0,955	-0,800	0,922	-0,891	0,827
2	0	0,119	0	0	0,413
4	0	0,103	0	0	0,207
5	-0,191	-0,043	-0,049	0,0128	0,165
7	0,1364	-0,031	-0,035	-0,009	-0,118
8	0	-0,052	0	0	0,103
10	0	-0,024	0	0	-0,083
11	-0,087	-0,073	0,084	0,081	-0,075
13	0,0735	0,061	-0,071	-0,069	0,064
14	0	-0,017	0	0	-0,059
16	0	-0,026	0	0	0,052
17	-0,056	0,0126	0,0145	0,0038	0,049
19	0,0503	0,0113	0,013	-0,003	-0,044
20	0	0,021	0	0	0,041

Relative values of rotating magnetomotive force space harmonics are calculated using expression (5). Received results are presented in Table 5.

**Table 5.** Relative values of rotating magnetomotive force space harmonics of considered three-phase windings

Harmonic index	Winding type according to the numbers of presented figures				
	1	2	3	4	5
1	1	1	1	1	1
2	0	0,149	0	0	0,50
4	0	0,129	0	0	0,25
5	0,20	0,054	0,054	0,014	0,20
7	0,143	0,038	0,038	0,010	0,143
8	0	0,065	0	0	0,125
10	0	0,030	0	0	0,10
11	0,091	0,091	0,091	0,091	0,091
13	0,077	0,077	0,077	0,077	0,077
14	0	0,021	0	0	0,071
16	0	0,032	0	0	0,063
17	0,59	0,016	0,016	0,004	0,059
19	0,53	0,014	0,014	0,004	0,053
20	0	0,026	0	0	0,050

On the basis of the results from Table 5 the magnetomotive function distortion factors of considered windings were calculated according to the expression (1), and electromagnetic efficiency factors were calculated according to expression (6). Received results are indicated in Table 6 and in Fig. 7.

**Table 6.** Results of evaluation of electromagnetic properties of analyzed three-phase windings

Evaluation factor	Winding type according to the numbers of presented figures				
	1	2	3	4	5
$k_i$	0,962	0,969	0,991	0,993	0,830
$k_{ef}$	0,716	0,744	0,862	0,880	0,328

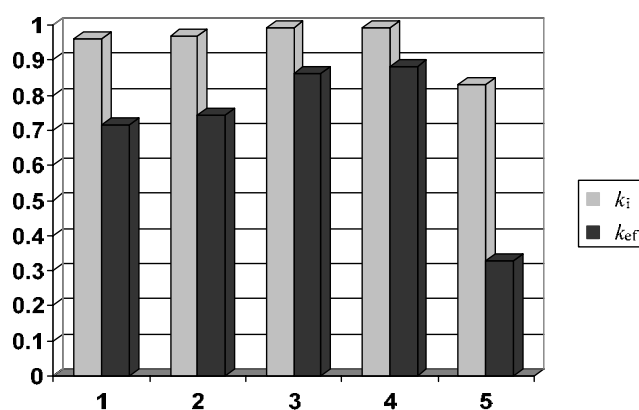

**Fig. 7.** The result evaluation diagram of electromagnetic properties of analyzed three-phase windings:  $k_i$  – distortion factors;  $k_{ef}$  – electromagnetic efficiency factors

## Conclusions

1. Electromagnetic properties of three-phase windings are still incompletely evaluated and substantiated.

2. Electromagnetic properties of three-phase windings can be evaluated more precisely after completing harmonic analysis of rotating magnetomotive force which is created by them.

3. Electromagnetic properties of three-phase windings can be compared against calculated distortion or electromagnetic efficiency factors, which are calculated using their rotating magnetomotive force harmonic analysis results.

4. From explored windings the best electromagnetic properties has two-layer former no fractional winding ( $k_i = 0,993$ ;  $k_{ef} = 0,880$ ), the worst properties – two-layer former fractional three-phase winding ( $k_i = 0,830$ ;  $k_{ef} = 0,328$ ).

5. Electromagnetic efficiency factors of three-phase windings are more suitable to reflect their electromagnetic properties than distortion factors.

## References

1. **Marazas S.** Electrical machines. – Science (Mokslas), Vilnius 1989. – 303 p (in Lithuanian).
2. **Kostrauskas P.** Asynchronous electrical machines. – Science (Technologija). – Kaunas, 1995. – 116 p. (in Lithuanian).
3. **Voldek A. I.** Electrical machines. – Energy, Moskva, Russian, 1978. – 832 p (in Russian).
4. **Žerve G. K.** Windings of electrical machines. – Leningrad: Energoatomizdat, 1989. – 399 p. (in Russian).
5. **Bessonov L. A.** Fundamentals of theoretical electrical engineering. – Moskva: Visšaja škola, 1978. – 653 p. (in Russian).
6. **Bukšnaitis J.** The Magnetic Fields Analysis of Three-Phase Excitation Windings // Elektronics and Electrical Engineering. – Kaunas: Technologija, 2003, No.1(43). – P.43–46 (in Lithuanian).

Submitted for publication 2006 12 22

**J. Bukšnaitis. New Approach for Evaluation of Electromagnetic Properties of Three-Phase Windings // Electronics and Electrical Engineering. – Kaunas: Technologija, 2007. – No. 3(75). – P. 31–36.**

A new approach for evaluation of electromagnetic properties of three-phase windings is presented, on the basis of which it is easy to compare different type windings of different parameters and to determine the optimal one. It is offered to evaluate momentary space no sinusoidal rotating magnetomotive force value using distortion factors or electromagnetic efficiency factors, which are calculated using the results of harmonic function analysis. The optimal values of both factors are equal to one. It was determined, that in order to evaluate electromagnetic properties of three-phase windings it is better to use electromagnetic efficiency factors than distortion factors. Ill. 7, bibl. 6 (in English; summaries in English Russian and Lithuanian).

**Ю. Букшнайтис. Новая оценка электромагнитных свойств трехфазных обмоток // Электроника и электротехника. – Каунас: Технология, 2007. – № 3(75). – С. 31–36.**

Представляется новый метод оценки электромагнитных свойств трехфазных обмоток, на основе которого легко сравнить обмотки различных типов или разнообразных параметров и установить оптимальную. Мгновенные пространственные несинусоидальные функции вращающейся магнитодвижущей силы трехфазных обмоток предлагаются оценивать коэффициентами искажений или электромагнитной эффективностью, которые определяются воспользуясь результатами гармонического анализа функцией магнитодвижущей силы. Оптимальные значения обоих коэффициентов равны единице. Установлено, что коэффициенты электромагнитной эффективности трехфазных обмоток лучше оценивают их электромагнитные свойства чем коэффициенты искажений. Ил. 7, библи. 6 (на английском языке; рефераты на английском, русском и литовском яз.).

**J. Bukšnaitis. Naujas trifazių apvijų elektromagnetinių savybių vertinimas // Elektronika ir elektrotechnika. – Kaunas: Technologija, 2007. – Nr. 3(75). – P. 31–36.**

Pateikiamas naujas trifazių apvijų elektromagnetinių savybių vertinimo metodas, kuriuo remiantis nesudėtinga palyginti skirtingų tipų arba įvairių parametrų apvijas ir nustatyti optimalią. Trifazių apvijų akimirkinės erdvines nesinusines sukamosios magnetovaros funkcijas siūloma vertinti iškreipčių arba elektromagnetinio efektyvumo koeficientais, kurie apskaičiuojami pasinaudojant magnetovaros funkcijų harmoninės analizės rezultatais. Abiejų koeficientų optimalios vertės yra lygios vienetui. Nustatyta, kad trifazių apvijų elektromagnetinio efektyvumo koeficientai geriau atspindi jų elektromagnetines savybes nei iškreipčių koeficientai. Il. 7, bibl. 6 (anglų kalba; santraukos anglų, rusų ir lietuvių k.).

DOI: 10.5755/j02.eie.10467