

An Artificial Neural Network Model for Feed Position of the Microstrip Antenna

V.R. Gupta, N. Gupta

Department of Electronics and Communication Engineering, Birla Institute of Technology, Mesra, Ranchi-835 215, India, e-mails: rch_vibharch@sancharnet.in, g_nisha@lycos.com

Introduction

Fig. 1 shows a microstrip antenna, which consists of a very thin metallic patch placed a small fraction of a wavelength above a conducting ground plane. The patch and ground are separated by a dielectric. The patch conductor is copper and can assume any shape [1-2]. The patches are usually photo etched on the dielectric substrate. The simplest method of feeding is through coaxial lines. The inner conductor of coaxial (probe) is connected to the radiating patch and outer conductor to the ground plane. Microstrip antennas have become very popular due to their several advantages such as simplicity, conformability, low manufacturing cost, lightweight, low profile, reproducibility, ease in fabrication and integration with solid-state devices. Microstrip antennas are used in broad range of application from communication systems to biomedical systems. However, the analysis of microstrip antennas are complicated and exhaustive. To optimize the antenna efficiency for transmitting and receiving the patch impedance should match with the feed. The patch impedance depends upon the feed position; hence it becomes very necessary to optimize the feed position.

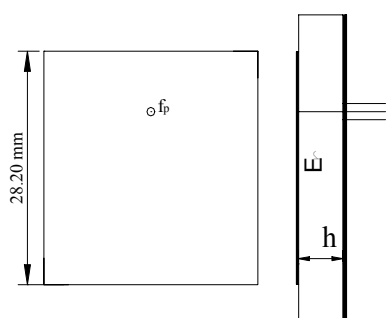

Fig. 1. A microstrip Patch Antenna

Recently, nonlinear neural optimization networks have been used for the designing of microstrip antennas [3-4]. In this paper, a Neural Network model for computing the feed position of rectangular microstrip patch antenna based on feed forward network and back propagation algorithm is presented.

Training Data and Generation

The network is trained with the data obtained from the mathematical formulation and PCAAD software [5]. The whole work has been divided into two phases. In first phase patch size (patch length and patch width) is varied for a fixed frequency and a neural network is trained for the feed position. In the second phase, resonant frequency and hence patch sizes are changed to develop a trained neural network (Fig. 2).

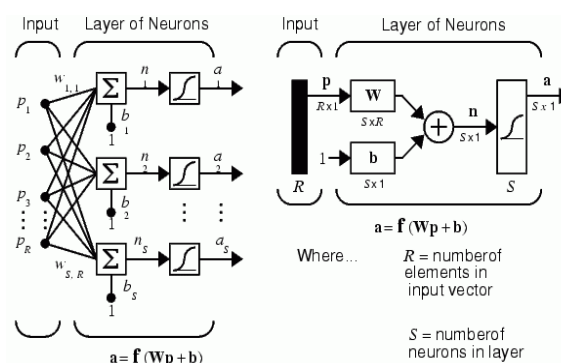

Fig. 2. Feed forward Network

Phase I. First, the patch dimensions for resonant frequency $f_0 = 2.45$ GHz, dielectric permittivity $\epsilon_r = 2.33$, dielectric thickness $h = 3.18$ mm were calculated as follows.

The initial value of length

$$L = \frac{c}{2(f_0 \sqrt{\epsilon_r})} = 40.1 \text{ mm.} \quad (1)$$

The effective permittivity is given by

$$\epsilon_{eff} = \frac{(\epsilon_r + 1)}{2} + \left[\frac{(\epsilon_r - 1)}{2 \left(1 + 12 \frac{h}{W} \right)^2} \right]^{-1/2}. \quad (2)$$

The fringe factor ΔL

$$\Delta L = 0.412h \frac{\left[\left(\epsilon_{eff} + 0.300 \right) \left(\frac{W}{h} + 0.264 \right) \right]}{\left[\left(\epsilon_{eff} - 0.258 \right) \left(\frac{W}{h} + 0.813 \right) \right]} \quad (3)$$

The physical or actual length of the path is given by

$$L = \frac{c}{2 \left(f_0 \sqrt{\epsilon_{eff}} \right)} - 2\Delta L \quad (4)$$

By using equations (1-4), lengths of patch were calculated for different values of width. Then for all the sets of lengths and widths, edge impedances (input impedance at the edge of patch) were calculated using PCAAD software. The distance x of feed position from the radiating edge of the patch was found using formula,

$$R(x) = R_0 \cos^2(\pi x/L), \quad (5)$$

where R_0 is the impedance at the edge of the patch; x is the distance of feed position from the radiating edge of the patch; L is the length of the patch.

The width w was varied from 10 mm to 55 mm to generate training data x .

Phase II. The frequency range is taken from 0.8 to 2.5 GHz with width ranging from 10 mm to 52.5 mm. Using equations (1-4) length of patch was calculated for different values of frequencies and widths. Training data for feed position were obtained using PCAAD and equation (5).

Results and discussion

Artificial neural network based on back propagation method using feed forward network was trained with the 91 sets of training data. The input vector has 2 rows containing the values of width and length. The target vector has single row of feed position. The parameters for the network training are: 1) the learning rate = 0.0128, 2) the number of epochs for training = 40,000 and 3) the performance goal = $1e^{-5}$.

The network parameters are: the number of hidden layers = 1 with 500 neurons and single neuron in the output layer. After training, network was used to calculate feed position for arbitrary value of width and length and result was compared with the value calculated from PCAAD. The result is shown in the Table 1.

Table 1. The obtained results

Serial No	Width (W in mm)	Length (L in mm)	Feed position obtained from trained network (mm)	Feed position Obtained from PCAAD software (mm)	Error
1	30.5	38.9365	10.2376	10.2358	0.0018
2	36.5	38.7017	8.7654	8.7642	0.0012
3	43	38.501	6.9810	6.9833	-0.0023
4	46	38.4223	6.0261	6.0269	-0.0008
5	51	38.3064	4.2810	4.2821	-0.0011

Then another network with frequency, length and width as input vector and feed position was as target vector was trained with 86 different sets of data. The network has one hidden layer containing 500 neurons and output layer containing single neuron. The performance goal was taken $1e^{-5}$ and number of epochs 55,000 during training. After training it was tested and compared with data calculated using PCAAD [5], which is shown in the Table 2.

Table 2. The obtained results

Serial No.	Frequency (f in GHz)	Width (W in mm)	Length (L in mm)	Feed position Obtained from trained network (mm)	Feed position Obtained From PCAAD Software (mm)	Error
1	1.12	18.0	90.5874	34.9935	34.9935	0.000
2	1.40	25.0	71.0259	25.1727	25.1722	0.0005
3	1.58	29.5	62.227	20.4933	20.4963	-0.003
4	1.86	36.5	52.0086	14.6711	14.6601	0.011
5	2.16	44.0	44.0777	9.4065	9.4069	0.0004

Conclusion

The neural model presented in this work gives almost accurate results and, requires no tremendous computational efforts. A distinct advantage of neural computation is that, after proper training, a neural network completely bypasses repeated use of complex iterative processes for new design presented to it. For engineering applications, this simple model is very useful. The neural models used in this work can further be extended to include other parameters like shape of the patch, choice of dielectric constant, its thickness, etc.

References

1. Carver Keith R., Mink James W. Microstrip Antenna Technology // IEEE Trans on Antennas Propagation. Jan 1981. – Vol.AP-29, No. 1. – P. 2–24.
2. Balanis C. A. Antenna Theory: Analysis and Design. – New York: Wiley, 1982.
3. Patnaik A., Mishra R. K., Patra G. K. and Dash S. K. An Artificial Neural Network Model for Effective Dielectric Constant of Microstrip Line // IEEE Trans. on Antennas Propagat. – November 1997. – Vol 45, No. 11. – P. 1697.
4. Mishra R. K., Patnaik A. Neural Network-based CAD Model for the Design of Square-Patch Antennas // IEEE Trans. on Antennas Propagat. – November 1998. – Vol 46, No. 12to – P. 1890–1891.
5. Pozar D. M. Personal Computer Aided Antenna Design. Ver. 2.1 // Antenna Design Associatesio – Leverett, MA, 1992.

V.R. Gupta, N. Gupta. Dirbtinio neuroninio tinklo modelis mikrojuostelinei antenai pozicionuoti // Elektronika ir elektrotechnika. – Kaunas: Technologija, 2005. – Nr. 4(60). – P. 87–89.

Nagrinėjamas dirbtinio neuroninio tinklo, skirto mikrojuostelinei antenai pozicionuoti tobulinimas, pateikiami tokie pageidaujami parametrai, kaip rezonansinio dažnio f_0 substrato storis ir sąlyginė dielektrinė skvarba ϵ_r . Tinklas pirmiausia yra treniruojamas keičiant fragmentų matmenis esant fiksuotam dažniui. Vėliau jis treniruojamas taikant visus tris kintamus parametrus, fragmentų matmenis (W and L) kartu su dažniu, siekiant tinkamai pozicionuoti tiekimą. Il. 2, bibl. 5 (anglų kalba; santraukos lietuvių, anglų ir rusų k.).

V.R. Gupta, N. Gupta. An Artificial Neural Network Model for Feed Position of the Microstrip Antenna // Electronics and Electrical Engineering. – Kaunas: Technologija, 2005. – No. 4(60). – P. 87–89.

The current work deals with the development of an artificial neural network for fixing the feed position of a microstrip antenna, given the desired parameters like resonant frequency f_0 , substrate thickness, and relative permittivity ϵ_r . The network is first trained by varying patch dimensions at a fixed frequency. Next it is trained with all the three varying parameters, the patch dimensions (W and L) together with the frequency, to obtain the suitable position of the feed. Ill. 2, bibl. 5 (in English; summaries in Lithuanian, English and Russian).

В.Р. Гупта, Н. Гупта. Модель искусственной нейронной сети для позиционирования микрополосковой антенны // Электроника и электротехника. – Каунас: Технология, 2005. – № 4(60). – С. 87–89.

Описывается развитие искусственной нейронной сети для позиционирования микрополосковой антенны. Представлены такие желаемые параметры, как толщина субстрата частоты f_0 и относительная диэлектрическая проницаемость ϵ_r . В начале сеть тренируется меняя измерения фрагментов при фиксированной частоте. После ее тренируют применяя все три изменяющиеся параметры, также измерения фрагменты (W and L) вместе с частотой с целью получить нужное позиционирование снабжения. Ил. 2, библи. 5 (на английском языке; рефераты на литовском, английском и русском яз.).

DOI: 10.5755/j02.eie.10417