

Corneal Thickness Factor and Artificial Intelligent Control for Intraocular Pressure Estimation

I. Sliesoraityte, A. Lukosevicius

*Department of Signal processing, Kaunas University of Technology,
Studentu str. 50, LT - 51368, Kaunas, Lithuania, phone: +370 686 51103, e-mail: sliesoraityte@yahoo.com*

V. Sliesoraitiene

*Department of Mechanics, Vilnius Gediminas Technical University,
J.Basanaviciaus str. 28a, LT-10225, Vilnius, Lithuania*

Introduction

Intraocular pressure is an impellent, guaranteeing the structural and physiologic optimum of an eye. Goldmann applanation tonometry (GAT) is the most widely applied in daily clinical practice, it is still recognized to be the most accurate intraocular pressure measurement device. The applanation tonometry is based on the Imbert-Fick law, which theoretically applies to perfectly flexible, infinitely thin, dry spheres. Goldmann and Schmidt acknowledged, that the premises of their construction are based on an assumption that central corneal thickness (CCT) is to be of the constant value, standard tightness and resistance either. The accuracy of their device would differ significantly if CCT deviates from this value, though sampling, experimental and analytical results are under consideration [1-2].

Central corneal thickness differences, observed among various racial and ethnic groups, day and season variability, CCT affected by chronic and acute diseases [3]. Even physiological CCT norm persist though a subject of discussions, GAT calibration margin exceeds the statistical average of CCT margin, and intraocular pressure (IOP) per se is a meaningful risk factor, significantly influencing the diagnosis, when treating and forecasting of various forms of glaucoma.

Current investigation focuses on IOP magnitude, being the basis in diagnosis and monitoring of ocular hypertension, valuation reliability. When employing the experimental data to create the correlation matrix of CCT, measured IOP via GAT and ocular hypertension; to prove the necessity of adoption of artificial intelligent methods based on supplement numerical analysis in respect of cornea deformable response in order to fix the reliability of the measured IOP magnitudes via GAT and introducing correction factor when required.

Methods

The performance of experimental modeling comprised of two cohorts, namely ocular hypertension and healthy subjects, was carried out at Vilnius University

Santarishkes hospital Ophthalmologic clinic. The confounding factors, contributing the accuracy and reliability of investigation were eliminated, when identifying maximal correlation of intraocular pressure versus central corneal thickness.

The intraocular pressure measurements were provided employing the Goldman applanation tonometry (Model AT 900 C/M). Intraocular pressure was analyzed separately for left and right eye having measured those in corneal center. The principle scheme for intraocular pressure measurements via GAT is presented in Fig. 1.

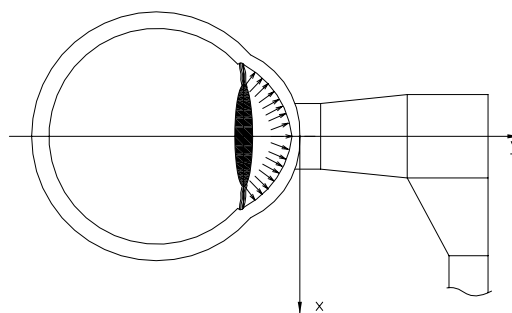

Fig. 1. Principle scheme for intraocular pressure measurements via GAT

A central corneal thickness measurements were performed via ultrasonic pachymeter (Quantel medical BVI France, model pocket, type BF, class II).

Statistical processing of relation CCT vs IOP

The experimental data were provided in respect of fifty three individuals, totally 96 eyes: 65 ocular hypertension cases and 34 healthy eyes were enrolled for the mathematical-statistical analysis. The observations were observed fully (i.e.100%) in respect of each individual investigated eye per considered time period. An identified ratio of ocular hypertension eyes versus healthy eyes was 1:1.9 assuming proportional distribution in respect both of gender determinant of ocular hypertension and healthy eyes samples.

The age dispersion of investigated subjects covered the bounds of maximal risk i.e. age minimum was 51 years that of maximum – 79 years. Note that the sampling of considered groups in respect of age is reasonable. The scattering parameters of intraocular pressure corresponding to ocular hypertension eyes group versus that of the healthy eyes group were analyzed. An identified 5 mmHg difference of intraocular pressure magnitudes scattering in populations under investigation is statically reliable one (i.e. $p < 0.01$), when the gender indicator per se does not influence in statistically reliable way to variation of intraocular pressure magnitudes. The hypothesis, stating that central cornea of eyes under ocular hypertension diagnosis subjects is 10% thicker versus healthy eyes, is introduced. The introduced hypothesis was verified via the t-test, employed for independent samples. The test numerical magnitudes agreed with the study data ($p < 0.01$). A mathematical association of ocular hypertension, pachymetry, tonometry and age parameters was created applying the Pearson correlation coefficient. A matrix of ocular hypertension, pachymetry, tonometry, age data is presented in Table 1.

Table 1. Matrix of ocular hypertension, pachymetry, tonometry and age data

Parameter		IOP	CCT	AGE
Pearson Correlation	IOP	1.000	0.648	-0.224
	CCT	0.648	1.000	-0.172
	AGE	-0.224	-0.172	1.000
Sig. (2-tailed)	IOP	0	0.0001	0.073
	CCT	0.0001	0	0.172
	AGE	0.0730	0.172	0

The statistical modeling of experimental data, proved the CCT to be confounding factor and positively correlated source of variation in intraocular pressure measurements among ocular hypertension subjects.

Cornea structural modelling and analysis

The whole eye is a volume structure containing a spherical shell shape thin walled cornea (see Fig. 2). The aim of the current section of the paper is to identify numerically the following relationships: apical displacement (point corresponding to highest/central point of cornea shell) magnitude versus cornea thickness (under constant intraocular pressure $p = 2.89$ kPa) and that of the reactive force of GAT versus cornea thickness.

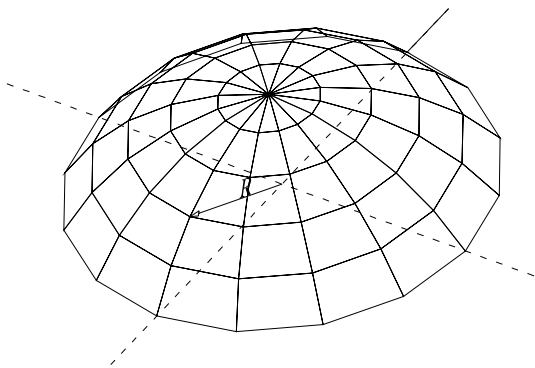

Fig. 2. Cornea parted from whole-eye structure

The classical shell analysis theories differ in respect of the shearing strains influence evaluation when describing the shell deformed state. The shearing strains influence to the shell cross deformation is evaluated in Timoshenko – Reissner – Mindlin theory. The Kirchof – Love theory ignores shearing strains, assuming the shell cross to remain plane during the deformation.

Applying the Kirchoff – Love theory and taking into account the loading peculiarities (no existing horizontal loading) the spherical shell stress state can be expressed via the following internal forces (integral resultants of cross-sectional stresses), applied onto the shell middle surface element edges (see Fig. 3).

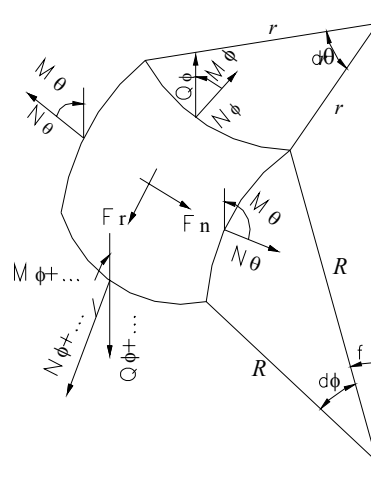

Fig. 3. Internal forces of cornea middle surface element

The shell internal forces selected into the vector are $\mathbf{S} = (M_\theta, M_\phi, N_\theta, N_\phi)$. Then the shell strain state is defined by the four-dimensional vector $\boldsymbol{\psi} = (\chi_\theta, \chi_\phi, \Delta_\theta, \Delta_\phi)$ dual to the vector of internal forces. Another pair of dual variables are the vector of external loads and that of displacements, reading $\mathbf{F} = (F_r, F_n)$, $\mathbf{u} = (u_r, u_n)$.

When the shell responds to the external actions (e.g. loading) by small displacements, the geometrical linear structural behavior model is introduced. For geometrically linear shell element (see Fig. 3) the equilibrium equations, reading:

$$\frac{N_\theta}{r} - \frac{1}{r} \frac{d(rN_\phi)}{dr} = F_\phi,$$

$$\frac{1}{r} \frac{dM_\theta}{dr} - \frac{1}{r} \frac{d^2(rM_\phi)}{dr^2} - \frac{N_\theta}{R} - \frac{N_\phi}{R} = F_n \quad (1)$$

remain constant during all loading stages. The equations (1) in matrix-vector notation can be written by $[C]^T \mathbf{S} = \mathbf{F}$. The compatibility eqns of strains and displacements (geometrical eqns) can be obtained in formal way, applying differential operator of equilibrium eqns $[C] \mathbf{u} = \boldsymbol{\psi}$. Analytically can be rewritten:

$$\begin{aligned}\chi_\theta &= \frac{1}{r} \frac{du_n}{dr}, & \chi_\phi &= -\frac{1}{r} \frac{d^2(ru_n)}{d^2r}, \\ \Delta_\theta &= \frac{u_r}{r} - \frac{u_n}{R}, & \Delta_\phi &= -\frac{1}{r} \frac{d(ru_r)}{dr} - \frac{u_n}{R}.\end{aligned}\quad (2)$$

If the shell responses to external actions (e.g. to loading) by relatively large displacements, the latter factor must be evaluated when creating the equilibrium and that of compatibility of strains and displacements eqns, i.e. the geometrical nonlinear structural behavior model is to be introduced for shell analysis. The experimental modelling, proved that the cornea deformable behavior in some deformation stages it is reasonable to evaluate via the geometrical nonlinearity model of large displacements and small strains. Then the structural response analysis is provided in iterative way, fixing the structure geometry changes per loading increments. In this case the differential operator of equilibrium (simultaneously that of geometrical - having it transposed) eqns is replaced by the new one - $[C^*]^T$, consisting from two parts, namely the first one, corresponding to geometrical linear behavior model - $[C]^T$, and the second, supplement one - $[C_{(u)}]^T$, fixing the geometry changes per loading increments. Then the equilibrium and geometrical eqns (1) and (2), containing $[C^*]^T$ (instead of only $[C]^T$) are valid for loading increments. Moreover, the splitting of the $[C^*]^T$ in two above mentioned parts, enable to provide the reasonable analysis of the geometrical nonlinearity factor contribution to structural response vs the geometrical linear structural response per total loading history.

Assuming the structure material to be described as physically linear one, the physical equations for shell element read (where E is material elasticity modulus, ν is Poisson's ratio, t is corneal thickness):

$$\begin{cases} N_\phi = \frac{Et}{1-\nu^2} (\Delta_\phi + \nu\Delta_\theta), \\ N_\theta = \frac{Et}{1-\nu^2} (\nu\Delta_\phi + \Delta_\theta), \\ M_\phi = \frac{Et^3}{12(1-\nu^2)} (\chi_\phi + \nu\chi_\theta), \\ M_\theta = \frac{Et^3}{12(1-\nu^2)} (\nu\chi_\phi + \chi_\theta). \end{cases} \quad (3)$$

The selection of the certain type nonlinear material constitutive law for structural analysis is conditioned by the reasonable approximation of the actual material physical behavior, approximated on the basis of the material testing data. The experimental data propose that human cornea material responses approximately linearly up to sufficiently high stress levels, close to 1000 psi (6.895Mpa).

The boundary conditions of the cornea shell edges represent the corneo-cleral connection deformable

response. The most accurate model of support conditions is obtained when having reasonably approached the single cornea shell deformable behavior (via modeling its boundary conditions) to the behavior of the one, being the structural part of the whole-eye discrete model under deformation. Investigation [1] proposed the boundary conditions for single cornea shell structure to be modeled via edge-roller supports with rotational springs.

The solution of the cornea shell discrete model full equations set, containing the equilibrium, geometrical and physical eqns (1)-(3) in respect of fixed boundary conditions result the all values, defining the stress and deformed state of the cornea, required to identify the targeted relations.

The experimental investigations proved the cornea linear (approximately) response in terms of displacements versus inner pressure in the range up to 4 kPa. Note that the latter relationship reflects only the integral effect of above mentioned nonlinearity cases (eventually to be met), contributing to the shell response magnitudes under consideration. The numerical simulations of cornea deformable response by means of continua finite elements via the Abaqus FEM package also resulted its linear displacement response vs inner pressure variation in the above mentioned range.

Numerical modeling IOP versus CCT

The stress and strain state evaluation problem when solving it analytically is rather complicated for actual design conditions (described above) and therefore numerical methods are employed for cornea shell analysis problem. Generally the continua finite elements are applied for shell response modeling.

To simulate the targeted relations with the aim to reduce the computational efforts, the authors proposed the continua cornea shell discrete model to replace by the space spherical shell discrete model with rigidly interconnected bar FEM mesh and pine-edge supports. The 7.77 mm radii cornea shell mesh was created by introducing the bars in 40 meridians and 100 parallels of the shell. All numerical simulations were provided applying the nonlinear finite element package MATRIX FRAME.

Identifying relation of cornea apical (maximal height) displacement versus corneal thickness. The simulations were provided for cornea, subjected by experimentally defined inner ocular hypertension pressure $p = 2.89$ kPa. The graphical view of obtained results is presented in Fig.4. One must note that obtained relation is be slightly nonlinear (it was observed from the apical displacement decrement dynamics due to equal corneal thickness increments of 0.01mm, employed in numerical analysis).

Simulating relation of GAT pressure versus central corneal thickness (including a comparison of results with the ones measured experimentally: i.e. with the authors experimental data of the intraocular pressure, measured by GAT for different central cornea thickness of individuals). GAT was pressed to the central point of the eye cornea during observations. The numerical experiment design model is created by introducing the additional vertical support link at apical point in the discrete model, being already employed for previous simulations.

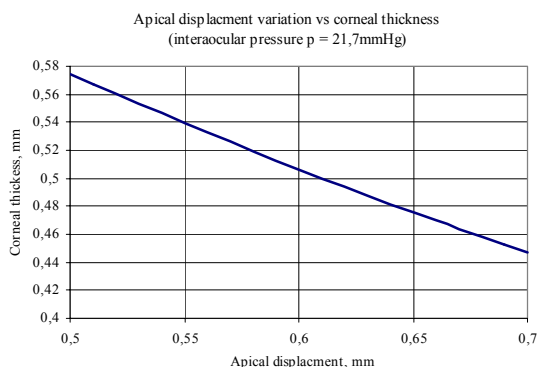

Fig. 4. Apical displacement reduction dynamics vs cornea thickness increment

The reaction of the link (GAT) is induced by the vertical displacement of this support link, directed in the way to compress the cornea. The simulated and experimental data are presented in the Fig 5.

The numerical simulations of the GAT were provided for the constant geometry and physical properties of the discrete model. The distribution of experimental results can be explained by nonhomogeneity factor of cornea, individual variation of elasticity modulus and/or other parameters of subjects, systemic measure error of GAT, other factors, not evaluated or ignored in the mathematical model. But find the simulated relation (see regular curve (series 1) in Fig. 5) to be close to the expected result of the experimental data, that proves the numerical method reliability.

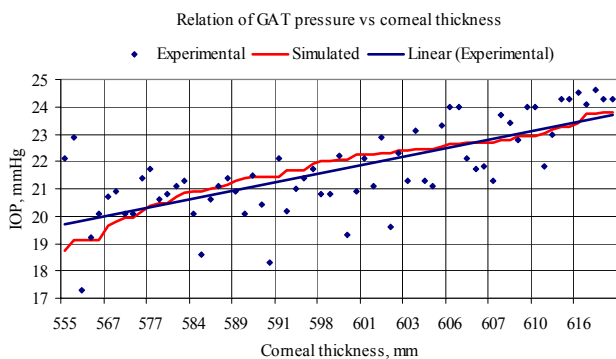

Fig. 5. Simulated (Series 1) and experimental (Series 2) magnitudes of IOP vs cornea thickness

So, one can conclude that clinician, having measured IOP magnitudes via GAT must provide the additional analysis to fix the reliability of the measured results (i.e. to recalculate numerically the measured IOP by GAT for certain CCT when it is possible (more accurate way), or apply the relation $R = f(t)$, obtained on the basis of already provided simulations with certain physical and

geometrical properties of cornea structure (less accurate way)). Thus, one can conclude, that the certain level of artificial intelligent control and subsequent CCT correction factor must be introduced.

Conclusions

Actually the simulated relation $R = f(t)$ is valid for determinate values. Variation of R causes adequate variation of t . It is obvious that for actually reliable evaluation of above functionally related values the stochastic modeling is to be employed, evaluating other stochastic nature parameters of design model (mechanical behavior, physical properties, topology, design method accuracy, etc) but this is out of scope of the current investigation, restricted by R variation evaluation (as well as that caused by systemic GAT error) describing all other parameters as determinate values.

The reliability of employed bar shell discrete model for above numerical simulations in respect of targeted relations was checked, when comparing the structural response behavior in respect of the considered and the other deformable response values, numerically simulated via 3D shell finite elements and with these obtained experimentally. The results were consistent with the above results and viewed only the small differences caused by employed simplifications to shell discrete model. Thus, one can conclude to fix reliability of measured intraocular pressure magnitudes the artificial intelligent control in terms of numerical simulations via finite element method is essential. The convergence of proposed artificial intelligent control method proves it to be an appropriate alternative for ocular hypertension misdiagnose.

Literature

1. **Anderson K, El-Sheikh A, Newson T.** Application of structural analysis to the mechanical behaviour of the cornea // J. R. Soc. Lond. Interface, 2004. – No.1. – P. 1–13.
2. **Sliesoraitytė I, Lukoševičius A.** Corneal structural modeling and analysis // Proceedings of Biomedical engineering international conference. – Kaunas: Technology, 2004. – P.138-142.
3. **Doughty M.J., Zaman M.L.** Human corneal thickness and its impact on intraocular pressure measures: a review and meta-analysis approach // Surv Ophthalmol., 2000. – Vol. 44, No.5. – P.367–408.

I. Sliesoraitytė, A. Lukoševičius, V. Sliesoraitienė. Ragenos storio faktoriaus įtaka išmatuojamo akispūdžio vertinimui, adaptuojant dirbtines intelektuales technologijas // Elektronika ir elektrotechnika. – Kaunas: Technologija, 2005. – Nr. 3(59). – P.37-41.

Trukdančių faktorių identifikavimas dirbtinėmis intelektualiomis technologijomis – pagrindas, siekiant eliminuoti išmatuojamo akispūdžio klaidas. Tyrimas pagrįstas akispūdžio – dominuojančio veiksnio akies hipertenzijos diagnostikoje - patikimumo įvertinimu. Eksperimentinių duomenų statistiniu modeliavimu įrodėme, jog centrinės ragenos storis yra trukdantis faktorius ir teigiamas koreliacijos šaltinis išmatuojamo akispūdžio variacijoje akies hipertenzijos subjektų grupėje. Siekiant kontroliuoti išmatuojamo akispūdžio reikšmės patikimumą, būtina integruoti dirbtines intelektuales technologijas, įvedant skaitinį modeliavimą baigtinių elementų metodu. Atsižvelgiant į eksperimentinių duomenų statistinį modeliavimą, pateiktą skaitinį simuliaciją, galutinėje išvadoje, nurodome dirbtinių intelektualių technologijų kontrolės imperatyvą, įvedant CRS korekcijos faktorių, esant išmatuotam akispūdžiui via GAT. Pasiūlytas dirbtinės intelektualios kontrolės metodas įrodo, jog tai yra tinkama alternatyva siekiant išvengti akies hipertenzijos diagnostinių klaidų. Il. 5, bibl. 3 (anglų kalba, santraukos lietuvių, anglų ir rusų k.).

I. Sliesoraityte, A. Lukosevicius, V. Sliesoraitiene. Corneal Thickness Factor and Artificial Intelligent Control for Intraocular Pressure Estimation // Electronics and Electrical Engineering. – Kaunas: Technologija, 2005. – No. 3(59). – P.37-41.

Estimation and valuation of confounding factors via artificial intelligent technologies is of the main importance when eliminating intraocular pressure tonometric mistakes. Current investigation focuses on intraocular pressure (IOP) magnitude, being the basis in diagnosis and monitoring of ocular hypertension, valuation reliability. The statistical modeling of experimental data, proved the central corneal thickness (CCT) to be confounding factor and positively correlated source of variation in intraocular pressure measurements among ocular hypertension subjects. To fix reliability of measured intraocular pressure magnitudes the artificial intelligent control in terms of numerical simulations via finite element method is proposed. Referring to statistical modeling of experimental data and provided numerical simulations in general conclusion we point the imperative of the artificial intelligent control method applied for introduce of CCT correction factor when having measured IOP via GAT. The convergence of proposed artificial intelligent control method proves it to be an appropriate alternative for ocular hypertension misdiagnose. Ill. 5, bibl. 3 (in English, summaries in Lithuanian, English, Russian).

И. Слесорайтите, А. Лукошявищюс, В. Слесорайтене. Фактор роговичной толщины через искусственные интеллектуальные технологии для измерений внутриглазного давления // Электроника и электротехника. – Каунас: Технология, 2005. – №. 3(59). – С.37-41.

Расчет и оценка смешанных факторов через искусственные интеллектуальные технологии имеет исключительно важное значение для исключения тонометрических погрешностей внутриглазного давления. Настоящее исследование рассматривает величину внутриглазного давления, являющуюся основой диагностики и наблюдения за повышенным глазным давлением и надежности оценки. Статистическое моделирование экспериментальных данных доказало, что центральная роговичная толщина (СРТ) является смешанным фактором и положительно коррелированным источником вариаций в измерениях внутриглазного давления среди субъектов повышенного глазного давления. Чтобы обеспечить надежность измеренных величин внутриглазного давления, предложен искусственный интеллектуальный контроль в виде числовых моделирований через метод конечных элементов. Что касается статистического моделирования экспериментальных данных и обеспечения числовых моделирований в общем заключении, мы указываем на императив искусственного интеллектуального метода контроля, применяемого для введения поправочного коэффициента СРТ через GAT. Конвергенция предложенного искусственного интеллектуального метода контроля доказывает, что этот метод является соответствующей альтернативой неверной диагностики повышенного глазного давления. Ил. 5, библи. 3 (на английском языке; рефераты на литовском, английском и русском яз.).

DOI: 10.5755/j02.eie.10405