

The Investigation of Helicon Maser

Z. Jankauskas, V. Kvedaras, V. Zaveckas

Department of Electrical Engineering, Vilnius Gediminas Technical University,

Naugarduko 41-318, LT- 03227 Vilnius – 6, Lithuania, phone 370-5-2744762, e-mail: elektrotechnika@el.vtu.lt

1. Introduction

Helicons are magnetoplasmic waves propagating in semiconductors and metals when a strong magnetic field is applied. In our paper [1] the construction of Helicon Maser (HM) was described. The generation of helicons in the HM was obtained by the help of maser effect when the magnetoplasmic waves were excited by radio frequencies (the range 1000 MHz) much higher than the helicon generation frequency (main peak at 20 MHz). The higher frequency field may be called a pumping field. In analogy with the usual maser (or laser) the semiconductor sample plays the role of an active material and the connecting cable – the role of high quality external resonator. The bandwidth of the HM is much narrower than the bandwidth of isolated sample (the same situation as in case of laser).

The HM may be used for the contactless measurement of carrier density and mobility in semiconductors and semiconductors, RF antenna modelling, investigation of self - focusing and diffraction of e/m waves, etc [2].

The measurement of the HM bandwidth in working mode is rather complicated as the duration of helicon impulse is about 10 msec. In this paper the new experimental method of the HM bandwidth measurement is described.

2. Subject and Methods

The block diagram of the Helicon Maser is shown in Fig.1. Here 1 is semiconductor sample in the form of plate; 2 is excitation coil; 3 is pickup coil; 4 and 5 are the coaxial cable lines.

The direction of the coordinate axes x, y, z are also shown. The constant magnetic field H is directed along the axis z and is perpendicular to the sample plane $x-y$. The sample thick-ness is $2a$ and the dimensions of the plate in $x-y$ direction is much larger. In this case excited helicon is a circularly polarised plane wave of the form $\exp [i(kz - \omega t)]$.

The propagation vector k is take to be in the z direction and may be calculated from the dispersion relationship (it is assumed that $\omega_H \tau \gg 1$)

$$k = \sqrt{\frac{\omega_p^2 \cdot \omega}{\omega_H \cdot c^2} \left(1 + \frac{i}{2\omega_H \tau} \right)}; \quad (1)$$

where ω_p is the plasma frequency, ω_H is the cyclotron frequency, τ is the collision time, c is the velocity of light [3].

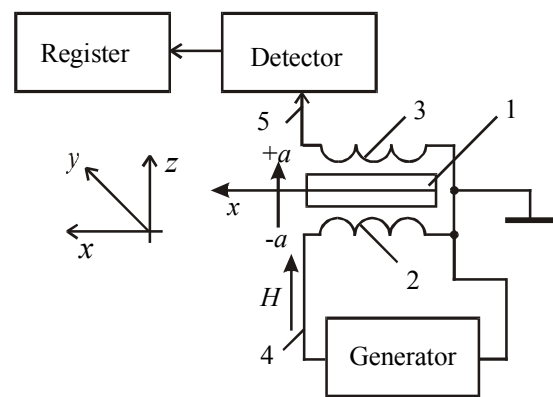

Fig. 1. The experimental device of Helicon Maser

For the n – type semiconductor the plasma and cyclotron frequencies are given by

$$\omega_p^2 = \frac{4\pi N e^2}{m}; \quad \omega_H = \frac{eH}{mc}; \quad (2)$$

where N, e, m are the density, charge and effective mass of the electrons (Gauss units).

The resonance frequency of the active material (semiconductor) may be found from the condition

$$(\text{Re } k)2a = \frac{n\pi}{2}, \quad n = 1, 3, 5, \dots \quad (3)$$

The Helicon Maser instabilities (generation and/or amplification) occur when the resonant frequency of the active material coincides with the resonant frequency of the cable line.

The quality of the semiconductor sample (active material) $Q_1 = \omega_H \tau \leq 10$. The long cable line quality Q_2 in the resonant mode is much higher $Q_2 = 4000$. The equivalent quality of HR Maser (active sample + long line resonator) in our experiments reaches the value $Q = 2000$.

The most appropriate material for the experimental realization of HM is n-InSb where $\omega_H \tau = 1$ condition may be achieved in the fields of 0.2 T (at the room temperature).

In the helicon maser (HM) is connected to the pumping RF generator with the frequency $f_2 = 100 - 2000$

MHz much higher than the helicon resonance frequency $f_1 = 20$ MHz the pick-up signal during the generation time is proportional to time function

$$F = \frac{f_2}{f_1} \sin 2\pi f_1 t - \sin 2\pi f_2 t \quad (4)$$

with the initial condition

$$F(0) = F'(0) = 0 \quad (5)$$

3. Experimental results

During the helicon generation time the first item in formula (4) represents the Helicon Maser response and is much larger than the second item (the pumping signal). Experimental results were obtained for a sample n-InSb (carrier density $N = 1,5 \cdot 10^{16} \text{ cm}^{-3}$; mobility $\mu = 5 \cdot 10^4 \text{ cm}^2 \text{ V}^{-1} \cdot \text{S}^{-1}$; sample thickness $2a = 0,5 \text{ cm}$; $T = 300 \text{ K}$). The main helicon generation peak was observed at $B = 1,55 \text{ T}$ with the helicon frequency $f_1 = 20 \text{ MHz}$ in the wide range of pumping frequencies $f_2 = 100 \div 2000 \text{ MHz}$. The typical Helicon Maser response is shown in Fig. 2 where the lower generation frequency f_1 peaks are superimposed on the higher frequency f_2 of the pumping field (eq.(4)).

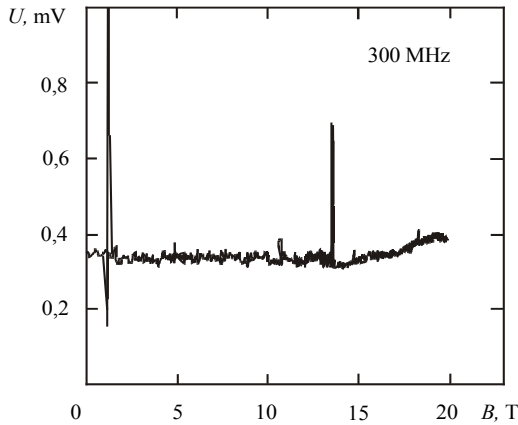

Fig. 2. The pick-up signal in millivolts versus constant magnetic field induction B in Tesla (pumping 300 MHz)

4. The HM bandwidth measurement results

The direct measurement of the HM bandwidth in working mode is rather complicated as the duration of helicon impulse is only about 10 msec. In this paper the new measurement method is described and all operations may be provided without pumping field.

The excitation coil in this case is connected to the RF source of the same frequency as helicon generation.

The process of the measurement is illustrated by Fig. 3, where U is the signal in the pickup coil and B is induction of constant magnetic field.

In experimental device Fig. 1 the generation frequency is 20 MHz. If the HM is excited by the RFs slightly less than 20 MHz we have the dependence $U = f(B)$ described by the curves 1, 2 and 3. The resonant curve 4 for $f_1 = 20 \text{ MHz}$ has the smallest bandwidth which coincides with the bandwidth of Helicon Maser in the working mode when pumping field (100 – 2000 MHz) is applied. For slightly higher excitation RF we have once again the wider curve 5. Experimentally the helicon

generation frequency and HM bandwidth may be determined by starting at the lower RF (curve 1) and continuously increasing the initial frequency.

In all cases the carrier density in the active material may be found by fixing the generation frequency f_1 and using the equations (1), (2) and (3) where $\omega = 2\pi f_1$.

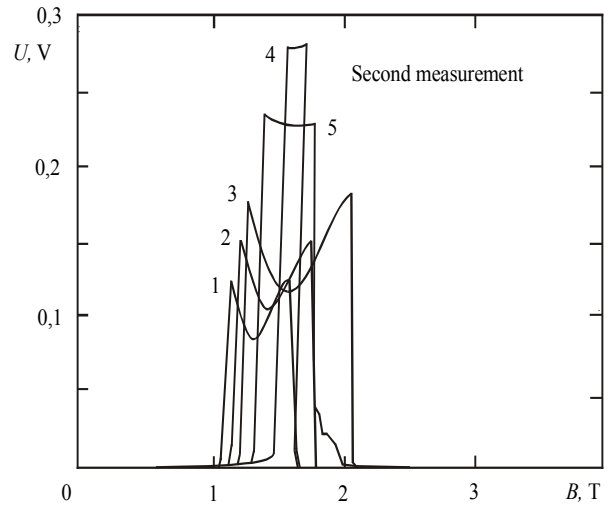

Fig. 3. The resonance curves of the HM for various frequencies of excitation: 1 – 19,3 MHz; 2 – 19,5 MHz; 3 – 19,7 MHz; 4 – 20 MHz (generation frequency); 5 – 20,5 MHz; U – the signal of pickup coil in Volts; B – magnetic field induction in Tesla

5. The equivalent circuit of HM

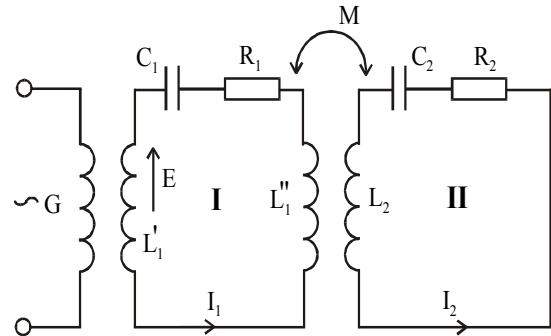

Fig. 4. The equivalent circuit of HM

The equivalent circuit of the HM is shown in Fig. 4. The helicon resonator is represented by the loop I with the active resistivity R_1 , capacitance C_1 and inductance $L_1 = L'_1 + L''_1$. The cable line - by the loop II (r_2, C_2, L_2). An external generator G develops an electromotive force \bar{E} in the first loop. The loops are connected by the mutual inductivity M . The resonant frequency ω_0 of both loops is the same

$$\omega_0 = 1/\sqrt{L_1 C_1} = 1/\sqrt{L_2 C_2} \quad (10)$$

The quality Q_1 of the semiconductor sample is small (loop I) and the quality of cable line resonator (loop II) is much higher

$$\begin{cases} Q_1 = \omega_0 L_1 / R_1 = \omega_H \tau \approx 10, \\ Q_2 = \omega_0 L_2 / R_2 \approx 4000. \end{cases} \quad (7)$$

In accordance with Kirchhof's voltage law we have two equations for the currents I_1 and I_2 in each loop

$$\begin{cases} I_1 \left(R_1 + j\omega L_1 - \frac{j}{\omega C_1} \right) - I_2 j\omega M = \overline{E}, \\ -I_1 j\omega M + I_2 \left(R_2 + j\omega L_2 - \frac{j}{\omega C_2} \right) = 0. \end{cases} \quad (8)$$

In resonant case $\omega = \omega_0$ we have instead of (8)

$$\begin{cases} I_1 R_1 - I_2 j\omega_0 M = E, \\ -I_2 j\omega_0 M + I_2 R_2 = 0. \end{cases} \quad (9)$$

The quality of all system (semiconductor sample+ cable line) will be the highest in the case of matched conditions when the mutual inductivity M is equal

$$M = \sqrt{R_1 R_2} / \omega_0. \quad (10)$$

Then

$$I_1 = E / 2R_1 \quad \text{and} \quad I_2 = jE / 2\sqrt{R_1 R_2}. \quad (11)$$

The quality Q of all equivalent circuit will be

$$\begin{aligned} Q &= \frac{I_1^2 \omega_0 L_1 + |I_2|^2 \omega_0 L_2}{I_1^2 R_1 + |I_2|^2 R_2} = \\ &= \frac{Q_1 + Q_2}{2} \approx 2000. \end{aligned} \quad (12)$$

(The equations (7 and 11) were used).

6. Conclusions

In the Helicon Maser magnetoplasmic waves are excited by the radio frequencies much higher than the helicon generation frequency. The excitation of helicons in this case may be described by the effect similar to the Combination Scattering (Raman effect) when a part of the high RF wave energy that passes through the active material is absorbed and re-emitted by the magnetized

solid – state plasma. The high RF e/m field may be called the pumping field. In analogy with the usual maser (or laser) the semiconductor sample plays the role of the active material and the connecting cable – the role of high quality external resonator. The bandwidth of the HM is much narrower than the bandwidth of isolated sample (exactly the same situation as in case of laser). The direct measurement of the HM bandwidth in working mode is complicated as the duration of helicon impulse is only about 10 msec. The new measurement method is proposed. Experimental results for an active material n-InSb were obtained in the range of constant magnetic fields $B = 0 - 20$ T and pumping frequencies 100 – 2000 MHz. The equivalent circuit of the HM is considered.

7. Acknowledgement

The experiments were performed at the Grenoble High Magnetic Field Laboratory (France) through the EEC "Access to Research Infrastructure action" Program.

References

1. **Jankauskas Z., Kvedaras V., Laurinavicius L.** Experimental realization of Helicon Maser in magnetized solid-state plasma // *Physica B.* – 2004. –Vol. 346-347. – P.539–542.
2. **Jankauskas Z., Laurinavicius L.** Magnetic and Electric excitation of Magnetoplasmic Waves. *Electronics and Electrical Engineering.* – 2002. – No 2 (37). – P. 32-35.
3. **Miner G.F.** Lines and electromagnetic fields for engineers. – Oxford University Press, 1996. – P. 1008.

Pateikta spaudai 2004 12 10

Z. Jankauskas, V. Kvedaras, V. Zaveckas. Helikoninio mazerio tyrimas // Elektronika ir elektrotechnika. – Kaunas: Technologija, 2005. – Nr.3(59). – P.70-72.

Įmagnetintoje kieto kūno plazmoje gali sklisti helikoninio tipo elektromagnetinės bangos. Helikoniniame mazeryje šio tipo bangos sužadina radio dažniais, gerokai aukštesniais už helikono generacijos dažnį. Generacijos juostos plotis šiuo atveju daug mažesnis negu izoliuotame puslaidininkiniame rezonatoriuje (ta pati situacija kaip ir lazeryje). Eksperimentiniame įrenginyje panaudota InSb medžiaga. Nuolatinis magnetinis laukas kito nuo 0 iki 20 teslų. Aptariama ekvivalentinė HM schema. Eksperimentai buvo atlikti Grenoble stiprių magnetinių laukų laboratorijoje (Prancūzija) pagal EEC programą. Il. 4, bibl. 3 (anglų kalba; santraukos lietuvių, anglų ir rusų k.).

Z. Jankauskas, V. Kvedaras, V. Zaveckas. The Investigation of Helicon Maser // Electronics and Electronicall Engineering. – Kaunas: Technologija, 2005. – No. 3(59). – P.70-72.

Radio frequency magnetoplasmic waves know as helicons will propagate in solid – state plasmas of metals and semiconductors when a strong magnetic field is applied. In Helicon Maser the helicons are excited by RFs much higher than the Helicon generation frequency. The bandwidth of HM is much narrower than in case of isolated sample resonator (the same situation as in laser). InSb was used for active material in the experimental device. The constant magnetic field varied within the interval 0 – 20 Tesla. The equivalent circuit of the HM is considered. The experiments were performed at the Grenoble High Magnetic Field Laboratory (France) through the EEC "Access to Research Infrastructure action" Program. Ill.4. bibl. 3 (English, summaries in Lithuanian, English and Russian).

З. Янкаускас, В. Квядарас, В. Завяцкас. Исследование геликонного мазера // Электроника и электротехника. – Каunas: Технология, 2005. – № 3(59). – С.70-72.

В намагниченной плазме твердого тела распространяются геликонные электромагнитные волны. В геликонном мазере волны этого типа возбуждаются при помощи радио частот значительно превышающих частоту геликонной генерации. Ширина полосы в этом случае значительно уже, чем в случае изолированного полупроводникового образца (аналогично ситуации в лазере). В экспериментальной установке использовали материал InSb. Постоянное магнитное поле менялось в пределах 0 – 20 тесл. Рассмотрена эквивалентная схема геликонного мазера. Эксперименты проводились в лаборатории сильных магнитных полей (Гренобль, Франция). Ил. 3, библи. 4 (на английском языке; рефераты на литовском, английском и русском яз.).

