

Detection of Signal Data Alternations by Forward Chaining XPS

A. A. Bielskis, O. Ramašauskas

Department of Computer Science, Klaipėda University,

H. Manto st. 84, Klaipėda, Lithuania, tel.: +370 46 398820, e-mail: {bielskis, olegas}@ik.ku.lt

Introduction

In the recent decade, there is an increasing consideration to the tracking control of robots, e.g., variable structure control, robust control, adaptive control, neural-network-based control, (adaptive) fuzzy control, and decentralized learning control [1–5]. In order to achieve the high performance requirements such as high-speed operation, increased accuracy in positioning, lower energy consumption, less weight, and safer operation due to reduced inertia, great attention has been paid to the dynamics and control of flexible robot arms in the recent years. However, the designed control system of the flexible robot arm must be able to control the motion of the rigid-body model of the arm and to suppress the vibration modes of the arm due to the flexibility of the flexible robot arm. Therefore, complex modelling procedures and complicated control techniques are usually required. These model-based control systems, originally designed for the demands of high performance, may not be so easy to implement in flexible arm control practice. It is due to uncertainties in design models and large variations of loads at robot hand, to the ignored high-frequency dynamics, and to the high order of the designed control system. Although many modern control techniques have been designed to overcome the mentioned difficulties by using complex control laws, these techniques require an exact knowledge of the nonlinear terms, knowledge of bounds on uncertainties, or knowledge of a nonlinear regression matrix of robot functions.

In practice, it is very difficult to have such a priori knowledge of the inertial and friction parameters used in dynamic models of robotic systems. These parameters are usually determined experimentally. In this paper we present a redesigned expert system to visualise robotic system positioning and sensor data signals based on experimentally assembled expert knowledge base.

Expert systems are based on the principle of passing the knowledge of a human expert onto the system and using it with the same results as the consulting expert. Expert systems can be a very efficient tool for the fast, high quality decision-making but cannot fully replace humans and cannot solve non-standard situations. Simply stated, the statement of an expert system corresponds to the conclusions and recommendations of a colloquy of top experts in

the field, whose advice can either be taken or disregarded [6].

The primary goal of expert systems research is to make expertise available to decision makers and technicians who need answers quickly. There is never enough expertise to go around - certainly it is not always available at the right place and the right time. Many small systems now exist that bring a narrow slice of in-depth knowledge to a specific problem, and these provide evidence that the broader goal is achievable. These knowledge-based applications of artificial intelligence have enhanced productivity in business, science, engineering, and the military. With advances in the last decade, today's expert systems clients can choose from dozens of commercial software packages with easy-to-use interfaces [7].

There are different types of expert systems based on production rules (rule-based expert systems, frame-based expert systems), neural networks, genetic algorithms, fuzzy logic, etc., as well as expert systems of a mixed type. For processing information of the type "assumption-hypothesis", i.e., "the, if-then" type of the decision, production rule-based expert systems provide the best solutions. On the other hand, neural networks are usually used for complicated or intuitive decisions, e.g. for the recognition of patterns of partial discharges (PD). Forward chaining is a data-driven inference process. The user of the system has to give all the available data before the start of the inference. The inference mechanism tries to establish the facts as they appear in the knowledge base until the goal is established by considering the same rule base [8].

In current research, we attempt to use rule-based expert system with forward chaining expertise. This paper proposes a method of signal data visualisation from ambient sensed non linear system. The proposed model of sensed signal data processing altered by newly redesigned Forward Chaining Expert System [10] (FXPS) is based on application of Matlab.

Analysis of robotic systems

In our research, we will use two joints manipulator (Fig. 1). The Euler-Lagrange equation is adopted to model the robot arm. The dynamic equation of an n -link robot arm [5, 9] can be presented

$$Q(t) = U(\theta)\ddot{\theta}(t) + h(\theta, \dot{\theta}) + c(\theta); \quad (1)$$

where $Q(t)$ is an $(n \times 1)$ vector of joint torques; $U(\theta)$ is the manipulator inertia matrix; $h(\theta, \dot{\theta})$ is an $(n \times n)$ vector of centrifugal and Coriolis effects; $c(\theta)$ is an $(n \times 1)$ vector representing gravity; $\theta, \dot{\theta}, \ddot{\theta}$ are $(n \times 1)$ vectors of joint positions, speed and accelerations, respectively.

The control of the simple planar robot arm with two revolute joints shown in Fig. 1 will be considered.

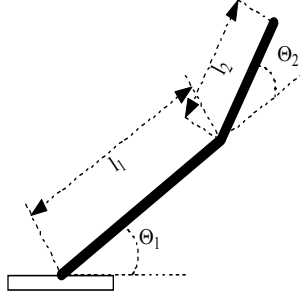

Fig. 1. The simple planar robot arm with joints

The elements of the dynamic equation (1) for this robot arm with electrical motor dynamics can be found:

$$U(\theta) = \begin{bmatrix} l_1^2(m_1+m_2) + m_2l_2^2 + 2m_2l_1l_2C_2 + J_1n_1^2 & m_2l_2^2 + m_2l_1l_2C_2 \\ m_2l_2^2 + m_2l_1l_2C_2 & m_2l_2^2 + J_2n_2^2 \end{bmatrix}, \quad (2)$$

$$h(\theta, \dot{\theta}) = m_2l_1l_2S_2 \begin{bmatrix} -2\dot{\theta}_2 & -\dot{\theta}_2 \\ \dot{\theta}_1 & 0 \end{bmatrix}, \quad (3)$$

$$c(\theta) = \begin{bmatrix} (m_1 + m_2)gl_1S_1 + m_2gl_2S_{12} \\ m_2gl_2S_{12} \end{bmatrix}, \quad (4)$$

where

$$C_i = \cos(\theta_i),$$

$$S_i = \sin(\theta_i),$$

$$C_{12} = \cos(\theta_1 + \theta_2),$$

$$S_{12} = \sin(\theta_1 + \theta_2),$$

J_i – moments of inertia for electrical motor I ,

n_i – factor of reduction gear I ,

θ_i are rotation angles,

m_i – mass of robot link.

The knowledge of the inertial and friction parameters used in a dynamic model of a robot is important for exact dynamic model-based or computed torque control. These parameters are rarely known in advance [1].

Adding the dynamic of the DC-motors, gears and variators, we find an eight order nonlinear equations system [5]:

$$[\theta_1, \dot{\theta}_1, \theta_2, \dot{\theta}_2, I_1, I_2, U_{m1}, U_{m2}]^T = [x_1, x_2, x_3, x_4, x_5, x_6, x_7, x_8]^T. \quad (5)$$

The equations (1) are quite complex, even for simple robotic arms. In practice, it is almost impossible to create mathematical model for complex manipulators. Further we will describe expert system used for robot arm control.

The Model of the Expert System

Our research has focused on developing an FXPS to provide the control robot arm with a simple and straight-forward interface that will allow the quick and accurate data detection. Our knowledge base is composed from manipulator's kinematical model parameters measured during experiments. Structure of proposed expert system (see Fig. 2) includes:

1. Module for collecting knowledge base;
2. Production rules based on forward-chaining;
3. Facts analysis re-entrant module.

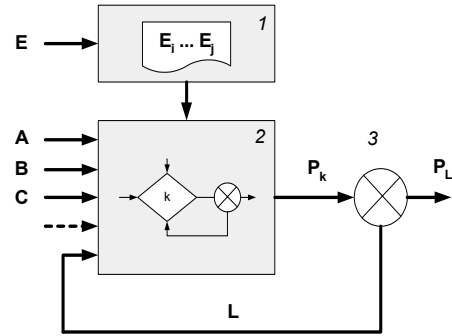

Fig. 2. Structure of the expert system [10]

Assuming that we know facts A, B, C, moreover, we have collected expert knowledge base, with facts $E_i \dots E_j$. These facts are being compared to initial facts by decision making engine, 2. New facts are returned to initial facts and processed repeatedly. Operation is repeated until no new facts found.

Expert data mining example

System configuration and operation is shown in Fig.3. Both data base (knowledge and initial facts) and decision making subsystem are realised as separate module.

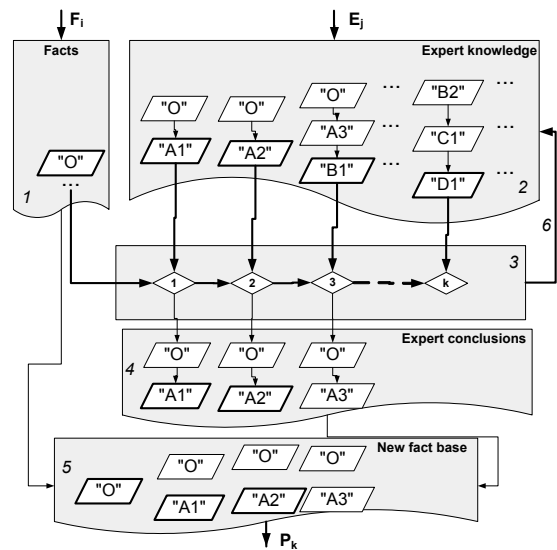

Fig. 3. Production scheme of one level expert system [10]

- The purpose of the module is as follows:
1. To produce an input file of facts;

2. To generate a file type knowledge base;
3. To generate production rules;
4. To make an expert conclusions;
5. To collect facts appended with conclusions;
6. To produce a reverse control for multiplicity.

While analysing the structure of the expert system, we can notice the similarity to a structure of the neural network. Recurrence, of the known facts in knowledge E_i ... E_j series, allows linking the recurrence rate with the weight coefficients of neural networks perception [10]. The basis for the production rule methodology is the application of simple if-then logic to the particular scenario. The Expert System code compares the incoming new data signal to those stored as expert knowledge.

Expert System is comparing data of facts (coordinates) against data of expert knowledge. In this case, the system is determining whether data are equal or not. If all conditions of the rule are valid, the code will return value true if coordinates are equal, and if not – the value false. In case of true, new control signal data is appended to recent fact. For simpler description of data mining process, we will encode signal data with symbolic expressions. For example, let A1 contains both the coordinates of the first joint ending, and, as an additional values, the manipulator control signal data. A production rules test only coordinates. Symbols B, C, D represent second, third and fourth joint's coordinates respectively. B2 represents another coordinates of the same, B, manipulator and so on. O is the default start position of rigid manipulator. Information available for expert system is as follows:

1. Goal, the coordinates of desired point, is
 >"D2";
2. Initial file of known facts is
 >"0".

Expert knowledge file contains all data which have been collected:

- 1> "0"; "A1"
- 2> "0"; "A1"; "B2"
- 3> "0"; "A1"; "B1"; "C3"
- 4> "A1"; "B3"
- 5> "B3"; "C2"
- 6> "B2"; "C1"; "D1"
- 7> "C3"; "D2"
- 9> "B3"; "C2"; "D2"

During first expertise cycle, new facts was found and added to the facts base:

- 2> "0"; "A1"

After the second cycle, it was obtained:

- 3> "0"; "A1"; "B2"
- 4> "0"; "A1"; "B1"
- 5> "0"; "A3"; "B3"

After the third loop, expert system found these new facts:

- 6> "0"; "A1"; "B2"; "C1"
- 7> "0"; "A1"; "B1"; "C3"
- 8> "0"; "A1"; "B3"; "C2" (2 times)

Fourth expertise cycle gives the following facts:

- 9> "0"; "A1"; "B2"; "C1"; "D1"
- 10> "0"; "A1"; "B1"; "C3"; "D2"
- 11> "0"; "A1"; "B3"; "C2"; "D2"

In the example, it is also shown that fact 8 was found 2 times and others – once. Recurrence rate of the fact can be assigned to its weight coefficient, and can be used to define the correctness of the fact. Desired goal is reached after four iterations. In this case, fact number 11 has the entire control signal data for moving the manipulator to position recorded in "D2". By default, fact validation is done alter one cycle and result is chosen by recurrence rate which defines fact correctness, so it is the fact 11 instead of the fact 10.

Although the Matlab Expert System approach currently is used to provide only a primitive form of production-rule base analysis, it represents an important first step in the use of Matlab to develop a suite of tools that can be used in detecting signal alternations. The Matlab software package has been shown to be quite flexible in case when it is coupled with the exceptional computation engine and available software enhancements. It means that the proposed in [10] Expert System can continue to evolve.

Graphical explication

For a simple use, we created a graphical user interface (GUI). Such GUI provides the operator with a simple menu-based control that allows each function to be initiated by the mouse click. In this GUI, conclusions made by expertise can be shown as converged objects (robot manipulator position) (see Fig.4).

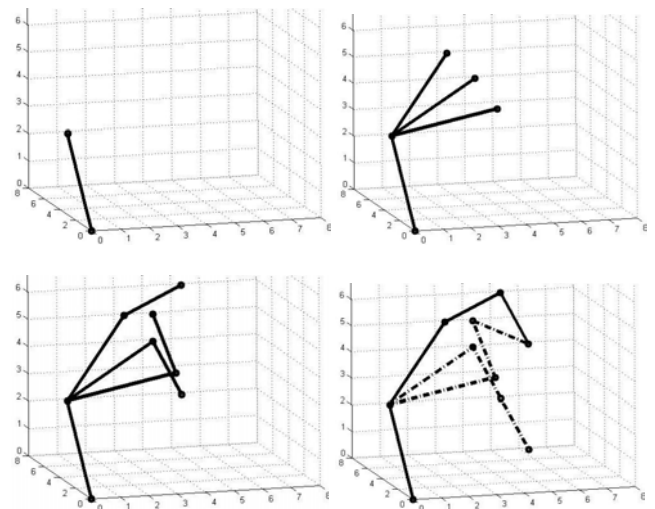

Fig. 4. Visualization of calculations (1–4 cycles)

By using Matlab environment, such Expert System is redesigned allowing the operator to execute the interface code. It allows to process and to visualize the resulting data as it is shown in Fig. 4.

Conclusions

The proposed expert system has some stronger or weaker sides of advantages: the expert system is universal and it can detect any signal data alterations; the results of expertise do not depend on kinematical and dynamical models; the expert system is strong in controlling changeable movement; a new knowledge can be easily appended.

Despite that, we can find some disadvantages of this expert system: control accuracy depends on the size of expert knowledge base; this expert system is not practical for controlling the same action.

Future task is to eliminate these disadvantages of proposed model by more enhanced usage of standard Matlab components like both a robust control and neural networks.

References

1. **Olsen M. M., Peterson H. G.** A new method for estimating parameters of a dynamic robot model // IEEE transactions on robotics and automation, 2001. – Vol. 17, No. 1. – P. 94–99.
2. **Tao Zhang, M. Nakamura, N. Kyura.** High-precision contour control of industrial robot arm by neural network compensation with learning uncertainties // IEEE int. symposium on Industrial electronics, 2001. – Vol. 3. – P. 1650–1655.
3. **Chih-Lyang Hwang, Shau-Fu Chao.** A fuzzy-model-based variable structure control for robot arms: theory and experiments // IEEE int. conf. "Man and Cybernetics", 2004. – Vol. 6. – P. 5252–5258.
4. **Rong-Jong Wai, Meng-Chang Lee.** Intelligent Optimal Control of Single-Link Flexible Robot Arm // IEEE transactions on industrial electronics, 2004. – Vol. 51, No. 1. – P. 2001–2020.
5. **Ionete C., Popescu D., Selisteanu D.** Robust control of two revolute Joints Robot Arm. Available at: med.ee.nd.edu/MED9/Papers/Robotics/Robotics_1/med01-119.pdf (accessed 2005-03-01).
6. **Zalis K.** Application of expert systems in diagnostics of high voltage insulating systems // Solid Dielectrics, 2004. – Vol. 2. – P. 691–694.
7. **Expert Systems.** Available at: <http://www.aaai.org/AITopics/html/expert.html> (accessed 2005-05-04).
8. **Krishnamoorthy C. S., Rajeev S.** Artificial Intelligence and Expert systems for engineers, CRC Press, 1996. – P. 31–45.
9. **Bakšys B., Federavičius A.** Robotų technika. – Kaunas: Technologija, 2004. – P. 141–160.
10. **Ramašauskas O., Bielskis A. A.** Ekspertinė sistema roboto judėjimams tirti // Elektronika ir elektrotechnika. – Kaunas: Technologija, 2002. – No. 1(36). – P. 52–57.

A. A. Bielskis, O. Ramašauskas. Detection of Signal Data Alternations by Forward Chaining XPS // Electronics and Electrical Engineering. – Kaunas: Technologija, 2007. – No. 2(74). – P. 45–48.

This paper proposes a method of visualisation of robotic devices signal data sensed from ambient environment of non linear system. The proposed model aims to detect the alterations of robot sensors signal data by using newly redesigned Forward Chaining Expert System (FXPS). The proposed simple expert system allows interpreting a matrix type data which describes the motions of robot hand as well as transformations of the objects in a symbolic form. The coherency using Expert System principles with Artificial Neural Network methods is also discussed. The software implementation in Matlab-based Expert System which provides production rule based signal data processing is also discussed. Visualisation results of the object graphical transformations are presented. Some efforts on support capabilities for the Expert System including the ability to edit rules and update expert knowledge data values have been focused in this paper. It is shown that the flexibility of the Matlab scripting language provides an Expert Systems platform a possibility to evolve if more features of knowledge base and production rules are included. Ill. 4, bibl. 10 (in English; summaries in English, Russian and Lithuanian).

A. A. Бельскис, О. Рамашаускас. Детектирование изменений сигналов данных с помощью прямой ЭС // Электроника и электротехника. – Каунас: Технология, 2007. – № 2(74). – С. 45–48.

Показано, как с помощью несложной рекурсивной экспертной системы можно обработать табличные и векторные данные перемещений руки манипулятора промышленного робота, трансформаций объекта и его перемещения. Замечено сходство с действием перцептрона в ИНС. Предложена функциональная схема экспертной системы, описаны особенности ее программной реализации и приведены образцы основных функций в среде MATLAB. Для улучшения самостоятельности системы разработаны и внедрены управляющие и контролирующие программные агенты, предложена функциональная схема экспертной системы, описаны особенности ее программной реализации и приведены образцы основных функций. Ил. 4, библи. 10 (на английском языке; рефераты на английском, русском и литовском яз.).

A. A. Bielskis, O. Ramašauskas. Signalų duomenų pokyčių aptikimas tiesiogine ekspertine sistema // Elektronika ir elektrotechnika. – Kaunas: Technologija, 2007. – Nr. 2(74). – P. 45–48.

Pateiktas metodas roboto įtaisų signalų duomenims, gautiems iš aplinkos jautriųjų netiesinių sistemų, vizualizuoti. Parodyta, kaip naudojantis naujai rekonstruota tiesioginio susiejimo ekspertine sistema aptinkami roboto įtaisų signalų duomenų pokyčiai. Straipsnyje aprašyta nesudėtinga originalia ekspertine sistema įmanoma apdoroti lentelių tipo duomenis (matricas), kuriuose simboliais yra aprašomas roboto rankos judesys, objektų transformacijos ir pan. Pabrėžiamas šios ekspertinės sistemos sąsajos ir dirbtinių neuroninių tinklų veikimo panašumas. Sukurtoji ekspertinė sistema Matlab aplinkoje gali pagal produkcijos taisykles apdoroti signalų duomenis. Darbe taip pat pateikta grafinių rezultatų pavyzdžių. Matlab scenarijų kalbos lankstumas leidžia sukurtajai ekspertinei sistemai suteikti naujų savybių. Numatyta galimybė papildyti žinių bazę ir produkcijos taisykles. Il. 4, bibl. 10 (anglų kalba; santraukos anglų, rusų ir lietuvių k.).

DOI: 10.5755/j02.eie.10368