

Investigation of a Magnetic Frequency Transducer on the Basis of Two-Collector Magnetosensitive of the Transistor

V. S. Osadchuk, A. V. Osadchuk

Vinnitsa National Technical University,

Khmelnitskiy Highway, 95, Vinnitsa - 21021, Ukraine, phone: (0432) 44-04-81; e-mail: osa@lili.vstu.vinnica.ua

Introduction

The measurement of parameters of a magnetic field, on the basis of which the considerable quantity of modern devices of an automation, diagnostics, computer equipment is constructed, is a basis of fundamental scientific investigations. Through magnetic measurements the structure and composition of substances, measurement long-range and near space, development of nuclear sources of power, magneto-hydrodynamic and cryogenic oscillators, high-speed terrestrial carrier on a magnetic pillow, accelerating engineering, aerial and sea navigating, methods of diagnostics in engineering and medicine is researched [1].

The majority of transducers of a magnetic field is analog, in which the magnetic field will be converted to an electric signal as a voltage or current. Usage of frequency transducers allows to receive a number of advantages before analog, which consist in considerable boosting of noise stability, that allows to magnify a measurement accuracy, and also in possibility of obtaining of major output signals. It establishes the premises of refusal from intensifying devices and A/D converters at an aftertreatment of a signal, that boosts profitability of the metering equipment [2, 3]. Usage magnetosensitive of the two-collector transistor both as sensing, and as an amplifier element has allowed considerably to simplify an electric circuit of a frequency converter of a magnetic field. In this connection the given article is devoted to investigation of a leading parameters of a frequency converter of a magnetic field.

Experimental investigations

The electric circuit of a transducer of a magnetic field is given in Fig. 1. It represents hybrid integrated circuit consisting from two-collector magnetosensitive transistor and field two-gate transistor, which establish the auto generating device, the frequency of which generation depends on induction of a magnetic field.

On electrodes of the first collector magnetosensitive of the bipolar transistor VT1 and drain field two-gate of the transistor VT2 there is a complete resistance, active component which has negative value, and reactive - capacitor character.

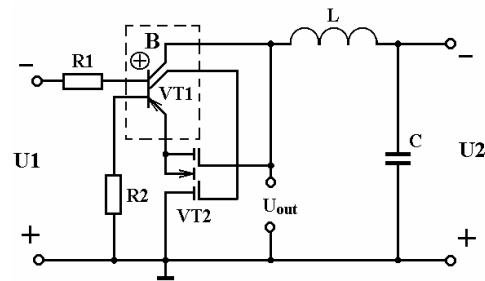

Fig. 1. An electric circuit frequency transducer of a magnetic field

Connection of inductance L to the first collector VT1 and common bus through short circuiting capacity establishes a tuning circuit, the power loss in which are cancelled by negative resistance. The resistors R1 and R2 provide a regime of supply on a direct current of the researched circuit. At action of a magnetic field on the transistor VT1 there is a variation of equivalent capacity of a tuning circuit, that calls variation of a resonance frequency.

The equivalent circuit, frequency transducer of a magnetic field is represented in Fig. 2. It is a line circuit, as the self-excited oscillator works in the field of low frequencies in a linear condition of operation.

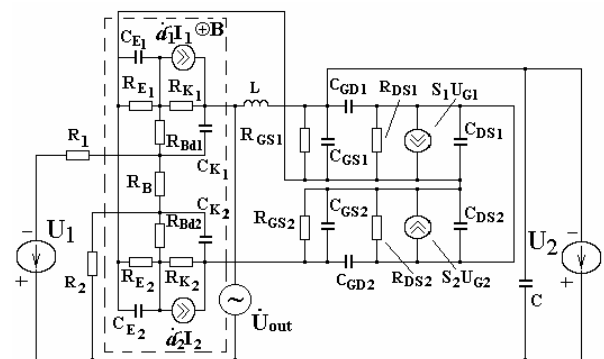

Fig. 2. An equivalent circuit of a frequency transducer of a magnetic field

Let's consider dependence of elements of an equivalent circuit magnetosensitive of the two-collector

transistor from effect of a magnetic field. Radiating from analytical dependences of parameters of an equivalent circuit [4] their dependence on a magnetic field is determined. The ohmic resistor of base area depends on action of a magnetic field as follows

$$R_B = R_{B0}(1 + c\mu_p^2 B^2), \quad (1)$$

where R_{B0} - resistance to base area without action of a magnetic field; μ_p - mobility of holes; c - coefficient, which depends on the mechanism of a dispelling of holes; B - the magnetic strength.

The dependence of resistance of emitter junction on action of a magnetic field is featured by expression

$$R_E = \frac{kT(1 + c\mu_p^2 B^2)}{qI_0 \cdot \exp(qU_{E0}/kT)}, \quad (2)$$

where k - Boltzmann constant; q - elementary charge; I_0 - reverse current emitter pn of junction; U_{E0} - constant voltage on emitter junction magnetosensitive of the transistor. The diffusion capacity of emitter junction depends on action of a magnetic field according to the formula

$$C_E = \frac{qI_0\tau_p \cdot \exp(qU_{E0}/kT)}{kT(1 + c\mu_p^2 B^2)}, \quad (3)$$

where τ_p - lifetime of holes. The collector-junction capacitance is featured by the formula

$$C_K = S \left[\frac{\varepsilon\varepsilon_0}{2U_K\mu_p\rho_0(1 + c\mu_p^2 B^2)} \right]^{1/2}, \quad (4)$$

where S - square of collector junction; ρ_0 - resistivity of base area; U_K - reverse voltage of collector junction magnetosensitive of the transistor; $\varepsilon, \varepsilon_0$ - dielectric factor of a semiconducting material of base area and vacuum, accordingly.

It is possible to present dependence, transmission ratio of a current in the circuit common-base in the field of low frequencies from actions of a magnetic field as

$$\alpha = 1 - \frac{1}{2} \left[\frac{W_0}{L_p(1 + c\mu_p^2 B^2/2)} \right]^2, \quad (5)$$

where L_p - diffusion length of holes; W_0 - width of base without effect of a magnetic field.

Thus, by spotting dependences of elements of an equivalent circuit on effect of a magnetic field, we shall transfer to determination of function of conversion and equation of sensitivity.

On the basis of an equivalent circuit according to a method of positive stability Lapunov [5] the function of conversion of the device is defined which represents dependence of frequency of generation on induction of a

magnetic field. The analytical dependence of function of conversion has sort

$$F_0 = \frac{1}{2\pi} \sqrt{\frac{A_1 + \sqrt{A_1 + 4LC_{GD}(C_B(B)R_B(B))^2}}{2LC_{GD}(R_B(B)C_B(B))^2}}, \quad (6)$$

where $A_1 = LC_{GD} - (C_B(B)R_B(B))^2 - C_{GD}C_B(B)R_B^2(B)$; L - external inductance; C_B, R_B - equivalent capacity and resistance to base area magnetosensitive of the transistor; C_{GD} - capacity a gate-drain of the field-effect transistor.

The graphics dependence of function of conversion is represented in Fig. 3. The sensitivity of a converter of a magnetic field is determined on the basis of expression (6) and is featured by the equation

$$\begin{aligned} S_B^{F_0} = & -0.0198 \left(-2C_B(B)R_B^3(B)C_{GD} \left(\frac{\partial C_B(B)}{\partial B} \right) \times \right. \\ & \times \sqrt{A_1 + 2A_2} - 2C_B^2(B)R_B^3(B) \left(\frac{\partial C_B(B)}{\partial B} \right) - 2C_B^3(B) \times \\ & \times R_B^2(B) \left(\frac{\partial R_B(B)}{\partial B} \right) - 3C_B(B)R_B^3(B)C_{GD} \left(\frac{\partial C_B(B)}{\partial B} \right) - \\ & - 2C_{GD}C_B^2(B)R_B^2(B) \left(\frac{\partial R_B(B)}{\partial B} \right) + 8C_B^2(B)R_B^3(B)L \times \\ & \times C_{GD} \left(\frac{\partial C_B(B)}{\partial B} \right) + 8LC_{GD}C_B^2(B)R_B^2(B) \left(\frac{\partial R_B(B)}{\partial B} \right) + \\ & + 4LC_{GD}R_B(B) \left(\frac{\partial C_B(B)}{\partial B} \right) \sqrt{A_1 + 2A_2} + 4R_B(B) \times \\ & \times \left(\frac{\partial C_B(B)}{\partial B} \right) LC_{GD} + 4C_B(B)LC_{GD} \left(\frac{\partial R_B(B)}{\partial B} \right) \times \\ & \times \sqrt{A_1 + 2A_2} + 4LC_{GD}C_B(B) \times \\ & \times \left. \left(\frac{\partial R_B(B)}{\partial B} \right) \right) / \left(\left(2\sqrt{A_1 + \sqrt{A_1 + 2A_2}} / A_2 \right) \times \right. \\ & \times \left. LC_{GD}C_B^3(B)R_B^3(B)\sqrt{A_1 + 2A_2} \right), \quad (7) \end{aligned}$$

where $A_2 = 2LC_{GD}(C_B(B)R_B(B))^2$.

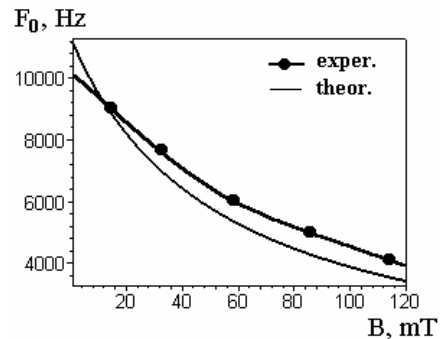

Fig. 3. Dependence of frequency of generation on induction of a magnetic field

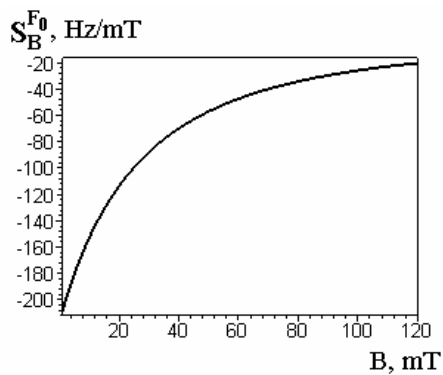

Fig. 4. Dependence of sensitivity on induction of a magnetic field

The schedule of dependence of sensitivity is represented in Fig. 4. As the greatest sensitivity of the device is visible from the schedule lays in a range from 0 up to 60 mT and makes 200-60 Hz/mT.

Conclusions

The possibility of direct conversion of induction of a magnetic field in frequency is shown on the basis of a hybrid integrated circuit consisting from two-collector

magnetosensitive of the transistor and field two-gate of the transistor. The analytical dependences of function of conversion and equation of sensitivity are obtained. The theoretical and experimental investigations have shown, that the sensitivity of a converter makes 30-200 Hz/mT.

References

1. **Микроэлектронные сенсоры** физических величин. Под редакцией З.Ю.Готры. В 3 томах. – Львов: Лига-Прес, 2003. Т. 2. – 595 с.
2. **Новицкий П.В., Кноринг В.Г., Гутников В.С.** Цифровые приборы с частотными датчиками. – Л.: Энергия, 1970. – 424 с.
3. **Осадчук А. В.** Микроэлектронные частотные преобразователи на основе транзисторных структур с отрицательным сопротивлением. – Винница: Универсум-Винница, 2000. – 303 с.
4. **Викулин И.М., Стафеев В.И.** Физика полупроводниковых приборов. – М.: Радио и связь, 1990. – 264 с.
5. **Каяцкас А. А.** Основы радиоэлектроники. – М.: Высшая школа, 1988. – 464 с.

Pateikta spaudai 2005 01 25

V. S. Osadčiuk, A. V. Osadčiuk. Magnetinio dažnių keitiklio tyrimas remiantis dviejų kolektorių tranzistoriaus magnetiniu jautriu // *Elektronika ir elektrotechnika*. – Kaunas: Technologija, 2005. – Nr. 2(58). – P. 33–36.

Pateikiami dažninio keitiklio magnetinio lauko tyrimai remiantis dviejų užtūrų lauko tranzistoriumi ir dviejų kolektorių magnetiškai jautriu tranzistoriumi. Apskaičiuotos ir eksperimentiškai pateikta keitiklio funkcijos ir jautris. Jautris sudaro 30-200 Hz/mT. Il. 4, bibl. 5 (anglų kalba; santraukos lietuvių, anglų, rusų k.).

V. S. Osadchuk, A. V. Osadchuk. Investigation of a Magnetic Frequency Transducer on the Basis of Two-Collector Magnetosensitive of the Transistor // *Electronics and Electrical Engineering*. – Kaunas: Technologija, 2005. – No. 2(58). – P. 33 – 36.

Investigations of a magnetic field frequency transducer on a basis two-gate field and two-collector magnetosensitive of transistors are represented. Are calculated and experimentally functions of a converter and sensitivity are given. The sensitivity makes 30-200 Hz/mT. Ill. 4, bibl. 5 (in English; summaries in Lithuanian, English and Russian).

В. С. Осадчук, А. В. Осадчук. Исследование магнитного частотного преобразователя на основе двухколлекторного магниточувствительного транзистора // *Электроника и электротехника*. – Каунас: Технология, 2005. – № 2(58). – С. 33 – 36.

Представлены исследования частотного преобразователя магнитного поля на основе двухзатворного полевого и двухколлекторного магниточувствительного транзисторов. Рассчитаны и экспериментально приведены функции преобразователя и чувствительность. Чувствительность составляет 30-200 Гц/мТ. Ил. 4, библи. 5 (на английском языке; рефераты на литовском, английском и русском яз.).

DOI: 10.5755/j02.eie.10365