

## Open Switch Faults Detection and Localization Algorithm for Three Phases Shunt Active Power Filter based on Two Level Voltage Source Inverter

T. Benslimane

University of Boumerdes, Algeria,  
e-mail: bens082002@yahoo.fr

### Introduction

The reliability of power electronic equipments becomes extremely important in general in industrial applications. The fault mode behaviour of static converters, protection and fault tolerant control of voltage source inverter systems has been covered in a large number of papers. Most of them are focused on induction motor drive applications.

D. Kastha and B. K. Bose considered various fault modes of a voltage source PWM inverter system for induction motor drive [1]. They have studied rectifier diode short circuit, inverter transistor base driver open and inverter transistor short-circuit conditions. However, they do not propose to reconfigure the inverter topology.

C. Thybo was interested in fault tolerant control of induction motor drive applications using analytical redundancy, providing solutions to most frequent occurring faults [2].

E. R. C. Da Silva and al investigated fault detection of open-switch damage in voltage source PWM motor drive systems [3]. They mainly focused on detection and identification of the power switch in which the fault has occurred. In another paper, they investigated the utilization of a two-leg based topology when one of the inverter legs is lost. Then the machine operates with only two stator windings [4]. They proposed to modify PWM control to allow continuous free operation of the drive.

More recently, E. R. C. Da Silva and al have studied fault tolerant active power filter system [5]. They proposed to reconfigure power converter and PWM control and examined a fault identification algorithm.

This present paper deals with open switch faults detection and localization in shunt active three-phase filter based on two level voltage source inverter controlled by current Hysteresis controllers. The proposed method is simple and reliable. It needs no more than active filter current sensors and display interface indicating the open faulty power switch.

First, an inverter based on standard three-phase power structure is presented. Fault diagnosis is detailed. Then,

shunt active filter hysteresis control is presented for three-leg structures. Finally, simulation results illustrating fault diagnosis and localization developed in the present paper are presented.

### System description

Fig. 1 presents a classical three-leg shunt active power system. It is composed of a grid ( $e_{si}$  for  $i = \{1, 2, 3\}$ ), a non-linear load, a voltage source converter. The load is a three phase diode rectifier feeding a series (R, L) load. The grid is supposed to be balanced with equal series resistance  $R_{cc}$  and inductance  $L_{cc}$  for each phase. The static converter is a voltage source inverter with equal series inductance  $L_f$  for each phase.

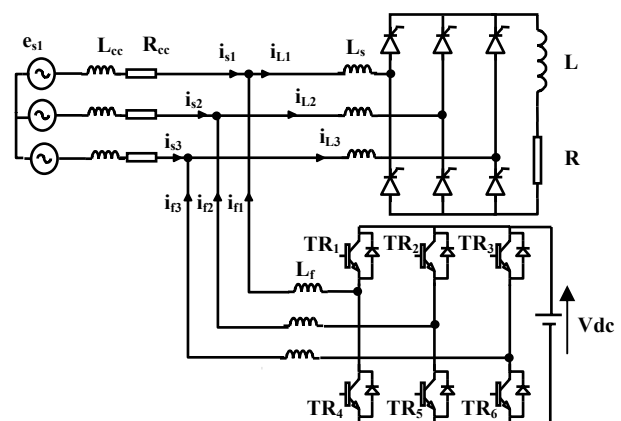

Fig. 1. Classical three-leg shunt active filter topology

The output currents of the shunt active filter are controlled by Hysteresis controllers to provide reactive power and harmonic currents generated by the non-linear load to ensure filtering.

Several faulty cases can occur: power switch or power switch driver can be faulty. In each case, it results in the following models:

- A switch is closed instead of being normally open.

It results in a short-circuit of the DC voltage source, increasing  $i_{123}$  current. To isolate the faulty switch as fast as possible, one can use fuses.

- A switch is open instead of being normally closed. It results in an open phase. The filter may continue injecting currents to the power supply. These currents don't cause any prompt risk because they are at the same range level as the case of no-fault condition. However, the filter in this case is polluting more the power supply instead of elimination of harmonic currents of non-linear load. This case is considered in this paper.

### Active filter control

Fig. 2 presents a block diagram of the proposed control system. The major advantage of this control principle is its simplicity and easiness to be implemented. The task of this control is to determine the current harmonic references to be generated by the active filter.

They are defined using classical active and reactive power method proposed by Akagi [6].

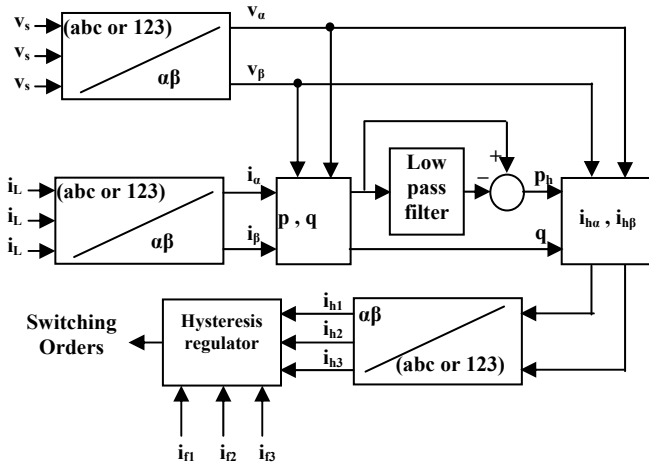

Fig. 2. Block diagram of the control system

By supposing that the main power supply voltages are sinusoidal, current harmonic references will be calculated like indicated in [7].

$(\alpha, \beta)$  voltage components at connexion point of active filter ( $v_\alpha, v_\beta$ ) and currents ( $i_\alpha, i_\beta$ ) are defined by the classical Concordia transformation:

$$\begin{bmatrix} v_\alpha \\ v_\beta \end{bmatrix} = \sqrt{\frac{2}{3}} \begin{bmatrix} 1 & -1/2 & -1/2 \\ 0 & \sqrt{3}/2 & \sqrt{3}/2 \end{bmatrix} \begin{bmatrix} v_{s1} \\ v_{s2} \\ v_{s3} \end{bmatrix}, \quad (1)$$

$$\begin{bmatrix} i_\alpha \\ i_\beta \end{bmatrix} = \sqrt{\frac{2}{3}} \begin{bmatrix} 1 & -1/2 & -1/2 \\ 0 & \sqrt{3}/2 & \sqrt{3}/2 \end{bmatrix} \begin{bmatrix} i_{L1} \\ i_{L2} \\ i_{L3} \end{bmatrix}. \quad (2)$$

The instantaneous real and imaginary powers, noted by  $p$  and  $q$ , are calculated by:

$$\begin{bmatrix} p \\ q \end{bmatrix} = \begin{bmatrix} v_\alpha & v_\beta \\ -v_\beta & v_\alpha \end{bmatrix} \begin{bmatrix} i_\alpha \\ i_\beta \end{bmatrix}. \quad (3)$$

These powers are then filtered by high-pass filters, which gives  $ph$  and  $qh$  and the harmonic components of the currents will be:

$$\begin{bmatrix} ih1 \\ ih2 \\ ih3 \end{bmatrix} = \sqrt{\frac{3}{2}} \begin{bmatrix} 1 & 0 \\ -1/2 & \sqrt{3}/2 \\ -1/2 & \sqrt{3}/2 \end{bmatrix} \begin{bmatrix} v_\alpha & v_\beta \\ -v_\beta & v_\alpha \end{bmatrix} \begin{bmatrix} ph \\ qh \end{bmatrix}. \quad (4)$$

### Fault diagnosis method

This section presents simulation results obtained with Matlab simulator for the proposed fault detection algorithm.

General simulation parameters are: main source grid: 220V,  $R_{cc} = 0.0148$  Ohm,  $L_{cc} = 0.175$ mH, 50 Hz; non-linear load:  $R = 40$  Ohm,  $L = 2$  mH,  $L_s = 0.2$  mH; active filter:  $V_{dc} = 700$  V,  $L_f = 5$  mH, currents regulators hysteresis band =  $\pm 0.5$  A. Mean value calculator computes the mean value of input signal over running window of one cycle of the specified fundamental frequency (50 Hz). For the first cycle of simulation, the output is held constant to the value specified by the parameter initial input (DC Component = 0 A).

These parameters are chosen to reduce THD of main source currents below 5%.

Fault detection is based on the calculation of zero harmonic component (mean value, dc offset) included in the active filter currents. A change in active filter current waveform is defined as the instant at which a sudden increase or decrease is observed in the DC offset component of the current. A change is considered to have occurred in the active filter current DC offset component of the current exceeds or falls below a given band (Fig. 3–6). If the open circuit faulty transistor is one of the upper transistors of the inverter based active filter, the current of the phase linked to that leg will have a negative DC component and the two other phases currents will have a positive ones (Fig. 4, Fig. 6).

If the open circuit faulty transistor is one of the lower transistors of the inverter, the current of the phase linked to that leg will have a positive DC component and the two other phases currents will have a negative ones (Fig. 5).

The open switch fault detection algorithm is developed to identify the faulty device as classified in Table 1.

Table 1. DC current Offset polarity corresponding to faulty open circuit transistor

Faulty Device	DC Current Offset Polarity		
	Phase1	Phase2	Phase3
TR <sub>1</sub>	negative	positive	positive
TR <sub>2</sub>	positive	negative	positive
TR <sub>3</sub>	positive	positive	negative
TR <sub>4</sub>	positive	negative	negative
TR <sub>5</sub>	negative	positive	negative
TR <sub>6</sub>	negative	negative	positive

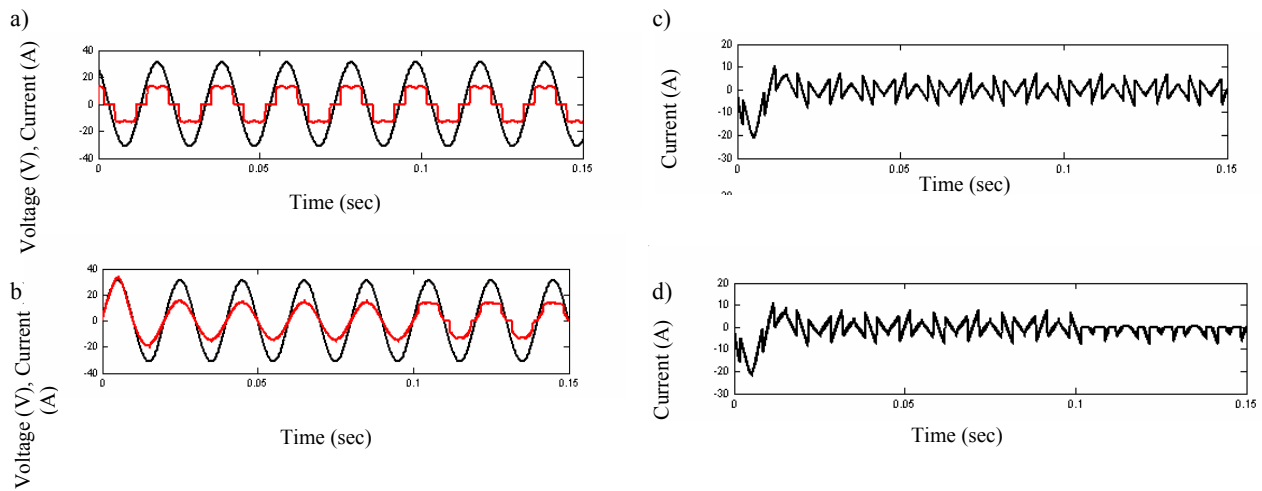

**Fig. 3.** Simulation results of active power filtering before and after TR1 open switch fault: a) Main phases 1 voltage instantaneous value / 10 and main phases 1 current instantaneous value ; b) Main phases 1 voltage instantaneous value / 10 and main phases 1 filtered current instantaneous value ; c) Harmonic identified phase 1 current instantaneous value; d) Active filter phase 1 current instantaneous value

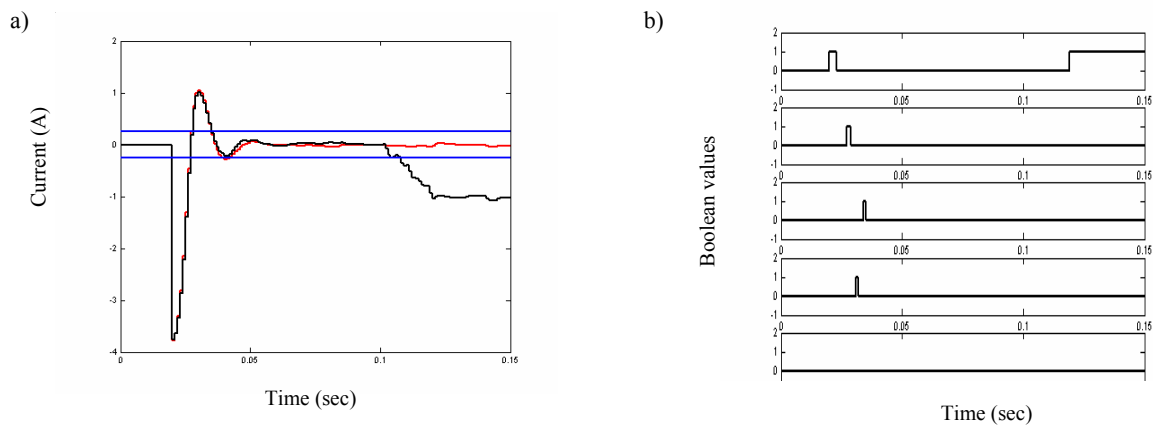

**Fig. 4.** Simulation results of open switch fault identification system before and after TR1 open fault condition (active filter currents mean values with their references mean values, Boolean outputs of diagnostic system): a) Phase 1 active filter current with its reference mean values; b) Boolean outputs of open switch fault detection system

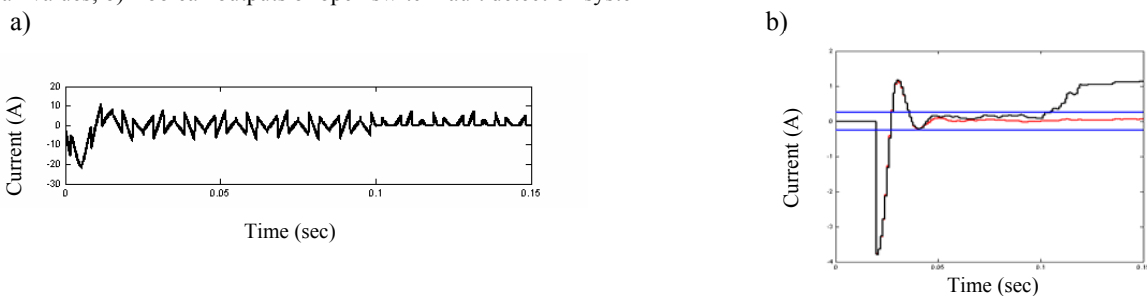

**Fig. 5.** Simulation results of open switch fault identification system before and after TR4 open fault condition: a) Active filter phase 1 currents instantaneous value; b) Phase 1 active filter current with its reference mean values

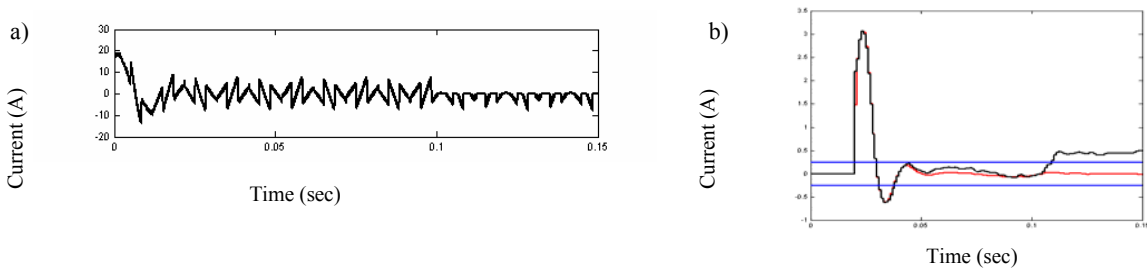

**Fig. 6.** Simulation results of open switch fault identification system: a) Active filter currents instantaneous values; b) Phase 3 active filter current with its reference mean values

Fig. 3–6 present results in an open switch fault cases (fault of respectively TR1, TR4 and TR2), introduced at  $t = 0.1$  s. Besides the delay time due to the transfer from safe operating steady state to fault operating steady state of active filter, it present a systematic delay time between 0 and  $T$  ( $T = 1/f$ ,  $T$  – one cycle (period) of active filter currents,  $f$  – frequency of active filter currents). These results show that the proposed fault detection algorithm is reliable and efficient.

## Conclusions

In this paper a simple, reliable and efficient open switch faults detection and localization in shunt active three-phase filter based on two level voltage source inverter controlled by current Hysteresis controllers is presented.

The semi conductor open fault detection method is robust to semi conductors switching and includes combinatory logic to perform reliability.

Simulation results demonstrate that when optimising active filter parameters, the zero harmonic component strategy can be used with robustness to detect and localize the open faulty switch in active filter inverter.

## References

1. **Kastha D., Bose B. K.** Investigation of fault modes of voltage-fed inverter system for induction motor drive // IEEE Transactions on Industry Applications. – Vol. 30, Issue 4, July-August 1994. – P. 1028–1038.
2. **Thybo C.** Fault-tolerant control of induction motor drive applications // Proceedings of the American Control Conference, 2001. – Vol. 4. – 25-27 June 2001. – P. 2621–2622.
3. **De Araujo Ribeiro R. L., Jacobina C. B., da Silva E. R. C., Lima A. M. N.** Fault detection of open-switch damage in voltage-fed PWM motor drive systems // IEEE Transactions on Power Electronics. – Vol. 18, Issue 2. – March 2003. – P. 587–593.
4. **Beltrao de Rossiter Correa M., Brandao Jacobina C., Cabral da Silva E. R., Nogueira Lima A. M.** An induction motor drive system with improved fault tolerance // IEEE Transactions on Industry Applications. – Vol. 37, Issue 3. – May-June 2001. – P. 873–879.
5. **Jacobina C. B., Correa M. B. R., Pinheiro R. F., Lima A. M. N., da Silva E. R. C.** Improved fault tolerance of active power filter system // IEEE 32nd Annual Power Electronics Specialists Conference PESC 2001. – Vol. 3. – 17–21 June 2001.
6. **Akagi H., Kanazawa Y., Nabae A.** Generalized theory of the instantaneous reactive power filter // Proceedings of International power electronics conference. – Tokyo, Japan, 1983. – P. 1375–1386.
7. **Benslimane T., Aliouane K.** A new optimized SVPWM Technique Control for Autonomous Parallel Active Filter // 11th International Conference on Harmonics and Quality of Power 2004. – New York, USA, IEEE Xplore, IEEE Transactions on Automatic Control. – P. 112–116.

Submitted for publication 2006 12 16

**T. Benslimane. Open Switch Faults Detection and Localization Algorithm for Three Phases Shunt Active Power Filter based on Two Level Voltage Source Inverter // Electronics and Electrical Engineering. – Kaunas: Technologija, 2007. – No. 2(74). – P. 21–24.**

An open switch faults detection and localization algorithm for shunt three phase active filter topology is proposed. It mainly details converter configuration and examines a simple and reliable optimised fault diagnosis method. The converter topology is based on classical three-leg active power filter topology. A new fault diagnosis method is proposed, based on classical currents measurements. It includes combinatory logic to analyse and validate error signals. A Hysteresis Control is applied before and after fault detection, which avoids any controller reconfiguration. Simulation results obtained with Matlab/Simulink/Plecs tools prove the effectiveness of this method. Ill. 6, bibl. 8 (in English; summaries in English, Russian and Lithuanian).

**T. Бенслиман. Алгоритм обнаружения и локализации неисправностей открытого типа для трехфазного шунтируемого активного фильтра мощности // Электроника и электротехника. – Каунас: Технологія, 2007. – №. 2(74). – С. 21–24.**

Предложен алгоритм обнаружения и локализации неисправностей открытого типа для топологии трехфазного активного фильтра. Описывается конфигурация преобразователя, исследуется простой и надежный метод диагностики неисправностей. Основной топологии преобразователя использована классическая топология активного трехфазного фильтра мощности. На основе классических результатов измерения тока предложен новый метод диагностики погрешностей. Для анализа и проверки сигналов погрешностей использована комбинаторная логика. Перед и после обнаружения неисправности использован гистерический контроль, применяя которого позволяет избежать повторной перенастройки контролера. Результаты моделирования, полученные применяя программные инструменты Matlab/Simulink/Plecs доказывает эффективность этого метода. Ил. 6, библи. 8 (на английском языке; рефераты на английском, русском и литовском яз.).

**T. Benslimane. Atviro jungimo gedimų aptikimo ir lokalizavimo algoritmas trifaziam šuntuojamam aktyviam galios filtrui dviejų lygių įtampos inverterio pagrindu // Elektronika ir elektrotechnika. – Kaunas: Technologija, 2007. – Nr. 2(74). – P. 21–24.**

Pasiūlytas atviro jungimo gedimų aptikimo ir lokalizavimo algoritmas, skirtas trifazio aktyviojo filtro topologijai. Straipsnyje aprašoma keitiklio konfigūracija, tiriamas paprastas ir patikimas gedimų diagnostikos metodas. Keitiklio topologijos pagrindu paimta klasikinė aktyvaus trifazio galios filtro topologija. Remiantis klasikinių srovės matavimų rezultatais pasiūlytas naujas klaidų diagnostavimo metodas. Klaidų signalams analizuoti ir tikrinti taikoma kombinatorinė logika. Prieš gedimą aptinkant ir jį aptikus, naudojama histerizės kontrolė, kurią taikant išvengiama pakartotinio valdiklio perdirinimo. Modeliavimo rezultatai, gauti naudojant Matlab/Simulink/Plecs programinius įrankius įrodo šio metodo efektyvumą. Il. 6, bibl. 8 (anglų kalba; santraukos anglų, rusų ir lietuvių k.).

DOI: 10.5755/j02.eie.10354