

Modeling of the Flexible Electronics Technologies

P. Balaišis, D. Eidukas, A. Žickis

Department of Electronics Engineering, Kaunas University of Technology,
Studentų str. 50, LT-51368 Kaunas, Lithuania, tel.: +370 37 300520, e-mail: andrius.zickis@gmail.com

Classification of flexible electronics technologies

Electronic devices (ED) were being created for a long time, operation of which was ensured by pre-determined interactions of electrical signals. Examples of such devices – the first electronic voltmeters, generators, temperature control gadgets, radio transceivers and others. Strictly determined unambiguous processes were taking place in these devices. Application technologies of such devices were also unambiguous and were not distinguished by high level of intellect. Only manufacture processes of these devices were distinguished by considerably wider variety, higher level of control dynamics and higher versatility. Therefore the conception of electronics technologies (ET), oriented towards manufacture processes, was formed traditionally.

The entirety of methods for alteration of states, properties and forms of raw-materials, materials and (or) semi-manufactures during the processes of manufacture was understood as ET [1].

However, at the present time these processes form only a part (sometimes even a small part) of all these technologies, related to electronics. Numbers of processes (often event of intellectual type) taking place in ED and their extent is increasing spontaneously. Entireties of ED application (during exploitation) technologies have proliferated even more. For this reason the earlier-used ET conception does not meet the needs of many researchers. New ET conception [2] has been formulated.

ET is the entirety of production processes, their methods and measures and the knowledge about them, associated with ED. The following were distinguished: information technology (the system of methods and measures of information acquisition, storing, processing and distribution); programming technology (the system of methods and measures of program creation and coordination); electronic control technology (the entirety of methods and measures for object and their state control using ED) and others. Thus most of ET can be divided into categories, as shown in Fig. 1.

The set of ET (T) consists of 750 separate variants of technologies ($\{T_i\}, i=1\dots 750$). Some certain one area ($\{S_i\}$), direction ($\{K_i\}$), branch ($\{\check{S}_i\}$) and (or) part ($\{D_i\}$) is characteristic to each separate ET variant (e.g. T_i). Each separate variant of every level (e.g. S_1) spans the entire set of different ET of this level (e.g. $\{S_{1j}\}, \{S_{ij}\}, \dots, \{S_{4j}\}, \dots, \{D_{5j}\}$). Therefore

$$\{T_{ij}\} = \langle \{S_{ij}\}, \{K_{ij}\}, \{\check{S}_{ij}\}, \{D_{ij}\} \rangle, \quad (1)$$

and the number of ET grows virtually limitlessly. This shows, that it is practically impossible to analyze comprehensively all the ET and to select the most rational. This peculiarity defines the methodology of scientific research of ET quality (efficiency).

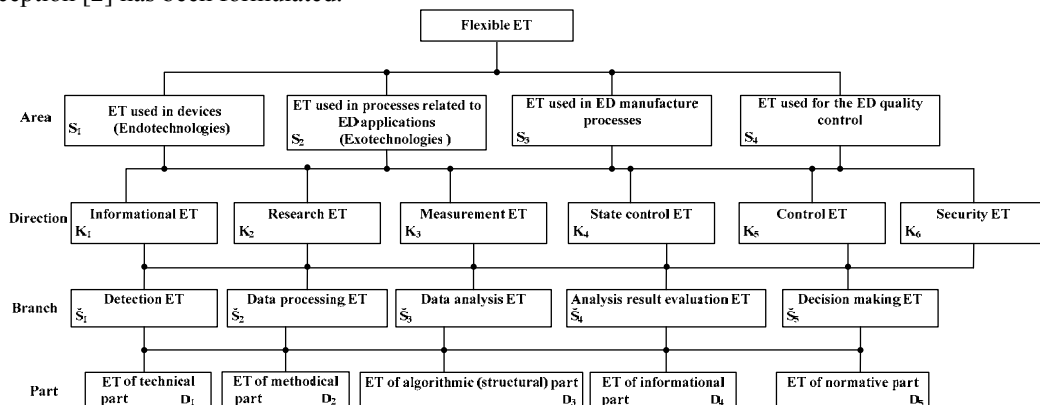

Fig. 1. The structure of the flexible ET

At first it falls to evaluate experimentally the importance of separate ET and their influence on the overall T_{ij} value and to select the most influential. Then the rational variant (T_{ir}) according to the point of view of experts is synthesized:

$$T_{ir} = \langle \{S_{ir}\}, \{K_{ir}\}, \{\check{S}_{ir}\}, \{D_{ir}\} \rangle \quad (2)$$

and its efficiency is analyzed. The minimal allowable (admissible) T_{ir} efficiency level, selected from the exploitation conditions, is set as the solution criteria. Therefore the base of ET analysis and synthesis methodology consists of evaluation of the level by which the experimentally selected technologies match the needs. The following operator characterized this conception:

$$\max_E E(\{S_{ij}\}, \{K_{ij}\}, \{\check{S}_{ij}\}, \{D_{ij}\}) \Big|_{E \geq E_0}; \quad (3)$$

here E – ET efficiency value; E_0 – minimal allowable ET efficiency valute.

It is obvious, that when implementing the operator (3) it is necessary to consider most peculiarities of the modern ET. Let's analyze several of them.

ET evolution trends and peculiarities

When improving the very various areas of human activities (cognition, control, security and other processes) one can not manage without ED. Various purpose ED are required. In most cases the tasks posed to ED are very similar. They differ only in the objects of cognition or control objects, initial data, their transmission or processing peculiarities and application areas. With time more and more various tasks are assigned to ED of every purpose. This determines the increase of complexity of ED and the processes inside them, the necessity to increase the versatility, degree of unification and modularity.

The environment of these devices and processes inside them is inconstant, and often – random. It falls to accommodate (adapt) to this environment. ET adaptivity – the ability of these technologies to accommodate to their variable structures, algorithms, functions or (and) environment conditions, including the input and output peculiarities also. That determines the necessity of adaptation measures (technical, programmical, informational and others) in these technologies. With development of ET and with their proliferation the higher and higher their adaptivity is required. It also falls to solve ET flexibility assurance problems in order to achieve the higher and higher ET versatility. ET flexibility is its ability to shift to the service of other objects, achievement of other goals, manufacture of other production – the solution of other problems. With the development of ED many areas emerge, in which it is required to solve ET flexibility assurance problems: the flexibility of informational processes; the flexibility of problem solution algorithms, the flexibility of control systems; the manufacture flexibility; the control flexibility; the security system flexibility, etc. The flexibility of informational processes is the ability of informational technologies to change the

procedures of information acquisition, transmission, processing or storing, or to perform other tasks.

The flexibility of algorithms is their ability to adapt to the new tasks, their solution situations and – when there is a need – to modify itself. The control system flexibility is their ability to change control object, objectives and (or) control efficiency criterions. The manufacture flexibility is the manufacture ability to shift to the production of manufacture objects of other types or modifications. The manufacture quality control flexibility is understood as the ability of control technologies to shift to the control of other products, the assurance of other quality levels and (or) other control methods. The flexibility of security systems consists of the possibilities to apply the security systems in order to secure various objects.

With constant increase of ET flexibility the problem of their component modularity assurance emerges. ET modularity is the possibility to separate it into unified parts – modules, which assure the possibility to use the same part into several ET areas, in several different technologies. Depending on the ET area, there can be memory, hard disc, program, functional, constructional, control, detection or other modules. The flexible modular ET are almost always controllable. That means that one or several electronic control systems (ECS) operate inside of them. When operating in non-stationary and often random environment these systems have a complex structure (CECS). Common objectives of several CECS lead to their integration. Integrated ES is understood as the entirety of inter-related electronic systems, which have joint objectives and joint control. The quality of systematized and integrated ET is often a function of time. With availability of some certain artificial intellect it operates, accumulates experience, teaches itself and changes in order to achieve more perfect state.

The efficiency of ET is mainly determined by its creator's position, although during exploitation of ET it is not directly accented. Static ET with determined behavior can look like sufficiently effective during design, but it will get old soon after its installation, because its application area will momentarily change after control implementation. Open, adaptive, flexible ET with self-learning functionality will be more promising, the objectives of which \bar{A} are the functions of time. Graphically such system can be represented as it is shown in Fig. 2.

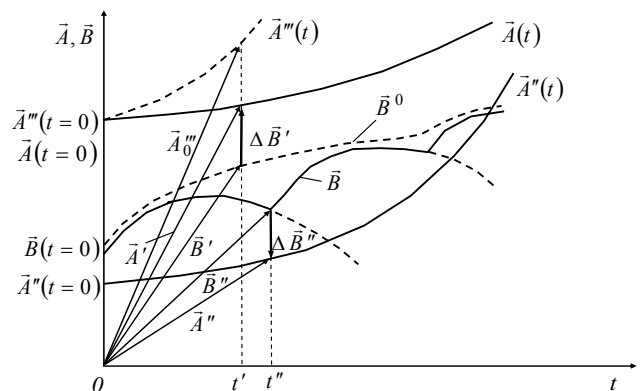

Fig. 2. The dynamics of ET objectives and states

In the beginning of the exploitation, ET objectives $\vec{A}(t=0)$ are higher than its states $\vec{B}(t=0)$. When exploiting the technology, its objectives and states vary; at first they approach the objectives, and later (do to control imperfection) start recede from them. After the correction of ET, its states begin to approach the objectives again, and later – to recede. When increasing the frequency of corrections it is possible to receive dynamics of \vec{B}^0 . In time moment t' ET objectives are \vec{A}' , and states – \vec{B}' . The vector difference $\vec{\Delta B}''$ indicates the necessity of control and determine the evolution of ET. When ET objectives \vec{A}'' lag behind the states \vec{B}'' (see $\vec{\Delta B}''$), its evolution is slowed down. When objectives (\vec{A}_0'') considerably outrun the states, the control efficiency decreases, since the almost unachievable does not promote the ET improvement.

Therefore the objectives posed to ET should be higher than states, but they should not be too distant from them. A problem of assurance of optimal systemic dynamics of these two vectors emerges [3]. Systemic dynamics is understood as the variation of inter-related objects, variation of inter-relation of their features in this case, with the pursuance of most rational ET evolution.

ET flexibility level is mostly determined by the peculiarities of ECS measures, and the expedience – by the demand for separate technology variants. So, the integrated ET should consist of the systems with various degrees of flexibility. This can be seen from the Fig. 3. The self cost (S) of ET also depends on that. (Fig. 4). Three groups of flexible ET creation principles should be distinguished:

- methodological principles,
- technical principles and
- organizational principles.

The following principles are considered as methodological: systematicity, complexity, flexibility, adaptivity, revolutionism, optimality, modularity, standardization, etc. The following is attributed to the second group: maximal viability of technical measures, rationality of the structures, unification of measures and etc. Principles of rationality of flows of direct information and its original source, control hierarchy and locality substantiation, control centralization and others can be attributed to the third group. The principle of revolutionism states, that when creating ET, the earlier-used old and non-interconnectable systems will be discarded. In most cases the first attempt to create the global ET control is usually unsuccessful.

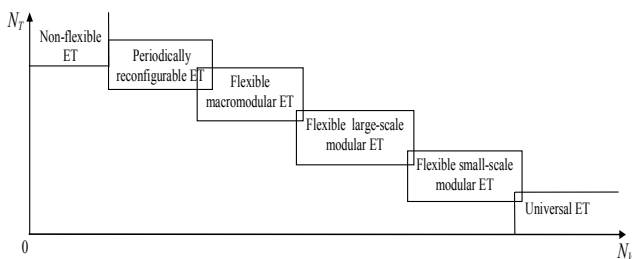

Fig. 3. The relation of ET flexibility to the number of its application variants (N_v) and their application intensity (N_T)

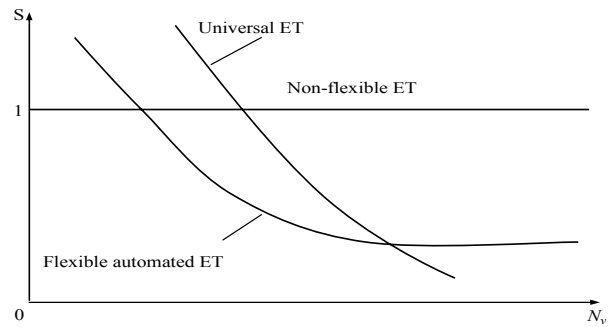

Fig. 4. Application area of flexible ET

For this reason the model of ET evolution before starting the design of ET network. This model allows gradual expansion of ET and rational integration of separate ET into seamless system. The methods of exointegration and endointegration could be used for this purpose [4]. For the exointegration it is characteristic that at first relatively small ET with its own ECS is created at first (Fig. 5, contour a) from a_N components, and later the ET control is improved, spanning more and more of the components a_M ($a_M > a_N$) (a' contour).

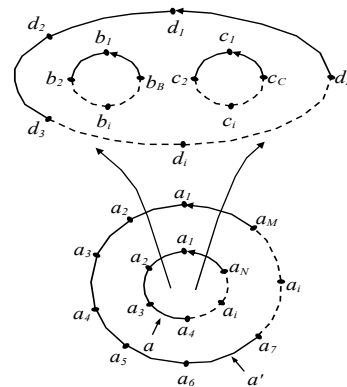

Fig. 5. The example of ET exodynamics

When particular level of component ($\{a_i\}$) integration into the system is reached, the system grows large, more inert, and because of that is divided into several systems with components $\{b_i\}$, $\{c_i\}$ and $\{d_i\}$. New systems are connected into integrated ECS. Such integration technique often permits the creation of more efficient integrated ET, since creation of new systems using the earlier ones assures more efficient interfaces between them. Endointegration can be carried out according the two directions: when joining several external systems (Fig. 6) into central, and when increasing the inner ECS integration.

When integrating according the first direction, not so efficient ET are obtained compare to earlier mentioned ET, since when using $\{a_i\}$ and $\{b_i\}$ components, problems of function incompatibility, objective ambiguity and others may arise in the integrated ($\{c_i\}$) system.

When integrating according the second direction, the information flows, interfaces, artificial intelligence, software measures, normative bases and other components are also integrated. Thus the ET efficiency steadily increases, however, the systematicity and complexity suffers.

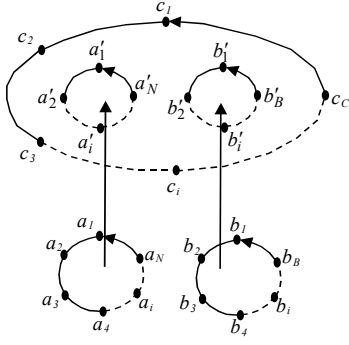

Fig. 6. The example of endodynamics

ET and their ECS creation algorithm is presented in Fig. 7.

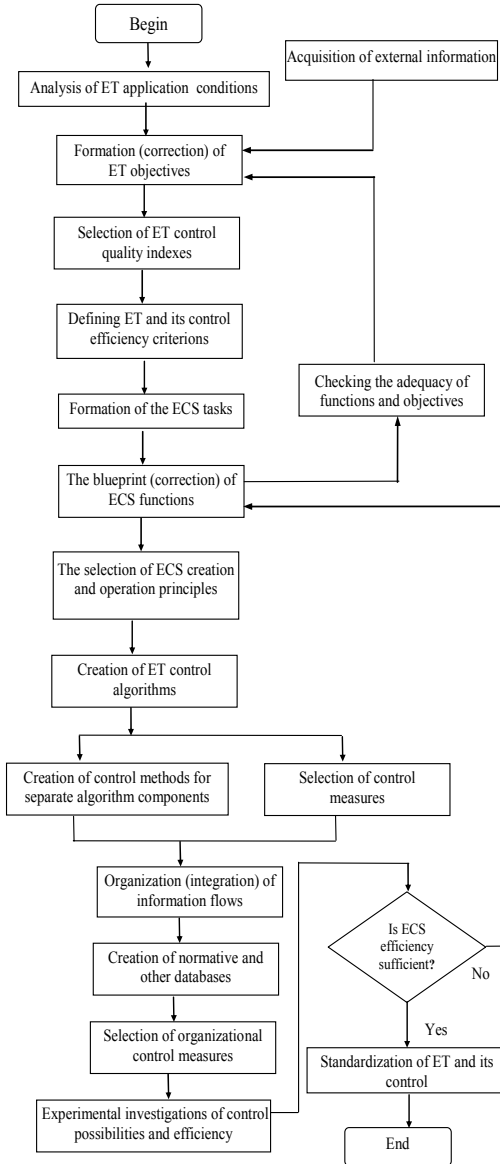

Fig. 7. ET ECS creation algorithm

Most of scientific problems emerge when creating methods of flexible ET efficiency evaluation and its increase methods. There is a need to design the scheme of modern (intellectualized) technology creation and operation so that it would be possible to investigate ET efficiency.

The structures of the flexible ET

As it was already pointed out, it is necessary to unify ET components, assure their modularity, controllability and increase the level of artificial intelligence in order to increase ET flexibility. When synthesizing such ET it is convenient to use ET and their component frames. ET frame is understood as the structural scheme (the backbone of its part) for the presentation of the knowledge about the peculiarities of this technology. After filling its elements (cells, slots, programs) using particular procedures, the ET of the selected purpose is obtained. This is the logical scheme of ET composition from the modules (agents) – the ET creation stereotype.

When creating flexible ET, the package of their tasks H is formalized at first. Assume, that it contains N_H tasks ($\{H_i\}, i = 1, \dots, N_H$) (Fig. 8).

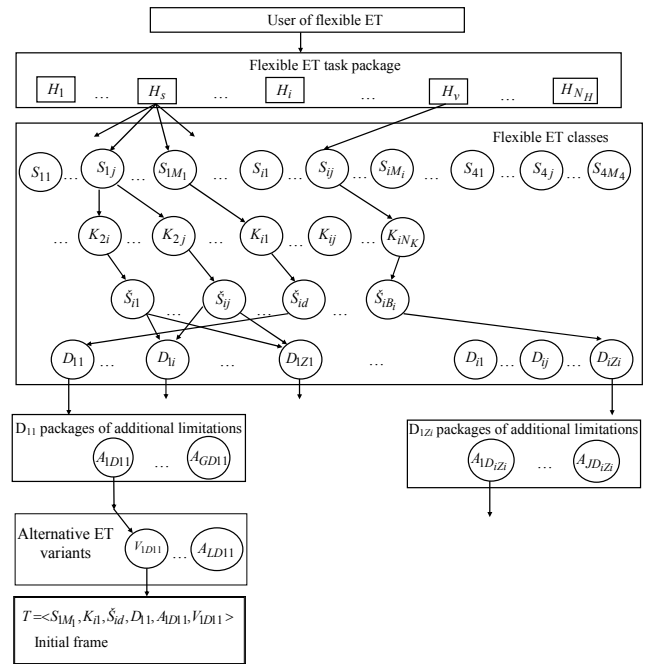

Fig. 8. The selection of initial frame for the flexible ET

After selection of some certain s -th or v -th task, the search for the particular ET (of particular class) is performed using the structure presented in the Fig. 1. This is represented by arrows in the block of selection of ET classes. After selecting the packages of additional limitations and one of alternative variants of that part of ET, the initial frame of the flexible technology is formed

$$T = \langle S_{1M1}, K_{1l}, \check{S}_{id}, D_{11}, A_{1D11}, V_{1D11} \rangle, \quad (4)$$

or in case when two ET, used in devices, are spanned,

$$T = \langle \langle S_{ij} \langle K_{2i}, \check{S}_{il} \langle D_{li}, \dots \rangle \langle D_{1Z1}, \dots \rangle \rangle \langle K_{2j}, \check{S}_{ij} \langle D_{li}, \dots \rangle \langle D_{1Z1} \rangle \rangle \langle S_{1M1}, K_{1l}, \check{S}_{il}, D_{11}, A_{1D11}, V_{1D11} \rangle \rangle. \quad (5)$$

Initial frame of the flexible ET is the minimal information about the user-selected technology, which is composed from their classes according to the modular principles, considering the limitations and the possible

alternatives. We will denote such frame in a short form as $T = \langle H_s \rangle$ or $T = \langle H_v \rangle$. $T = \langle H_s \rangle$ frames are classified into terminal ones (Fig. 9). Terminal ET frame is the lower level sub-frame of the main frame structure.

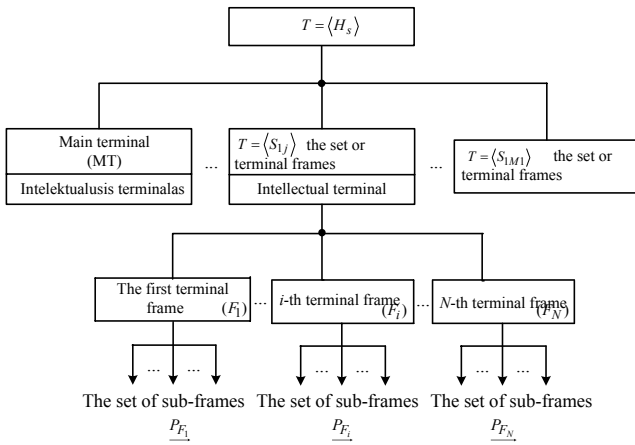

Fig. 9. $T = \langle H_s \rangle$ frame scheme

One main (MF) is located among terminal ET frames and several others. Main terminal frame is $T = \langle H_s \rangle$ frame terminal, from which it is possible to perform privileged control functions of all other terminals. As a rule, this is intellectual terminal, although not the only one of this type. Intellectual terminal is the terminal, which has the memory and the processor inside of it, which can solely evaluate and change its structure and (or) functions. Naturally, the initial frame also has the elements of artificial intelligence. Inner control is characteristic to all the intellectual terminals, and external control (when it is performed by other terminals) is characteristic to MT. Therefore each of them is a system, and in overall it is horizontally and vertically integrated [5] system (Fig. 10), in which their interdependencies can be illustrated using rectangles.

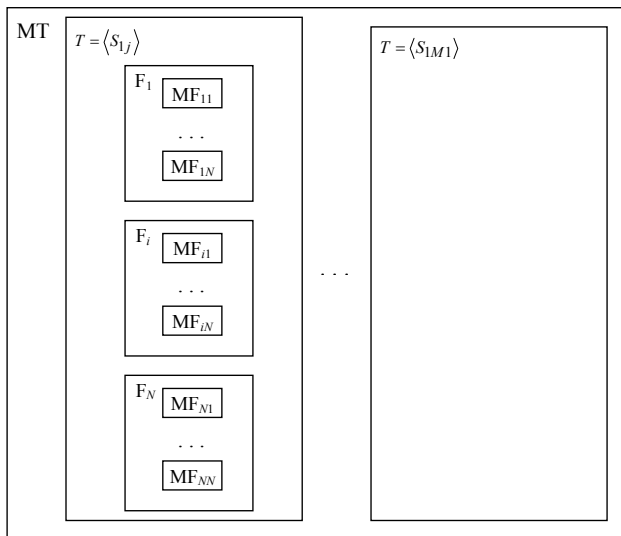

Fig. 10. Horizontally and vertically integrated ET control system

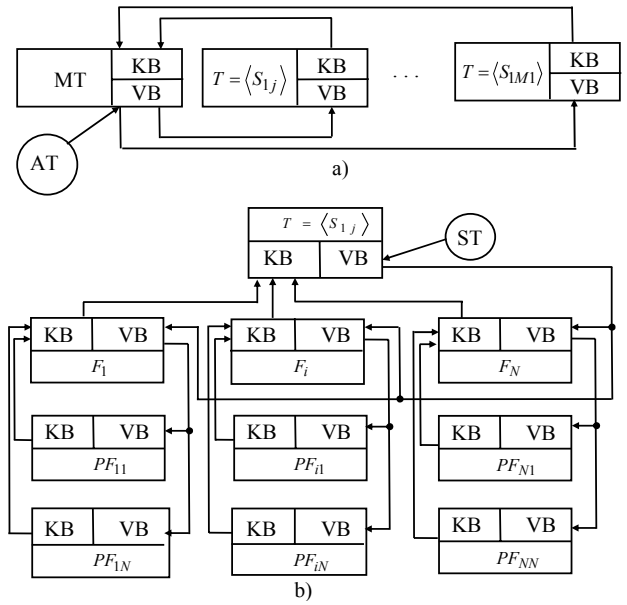

Fig. 11. Interconnections of integrated control measures of MT and $T = \langle S_{1j} \rangle$ systems

Control of the flexible ET

According to the request of the user, some certain task (e.g. H_s) is selected from the task block of the active ET. The control system (VS) of this level selects (considering the task peculiarities) the area (areas), directions, branches, parts, limitations and variants, from which the initial ET frame will be formed, describing the $T = \langle H_s \rangle$ implementation variant. In order to implement this variant, ET macrostructure is formed from the modular blocks. Considering the operation algorithm, initial and output information and also the tasks, the sets of sub-frames are selected, the control of separate ET parts and of ET itself is organized.

Information about component operation is accumulated in KB and transmitted to the KB of controlling system. Control commands from the controlling system VB are transmitted to the VB of controlled object. Considering the control systematicity, the synchronous (ST) and asynchronous (AT) controlling terminals are distinguished.

Synchronous terminal is the ET terminal, which is dedicated to change synchronously the operation of several components of the technology at the same time in a tunable manner. Typical control scheme of the activated (from the higher level) ET component is shown in Fig. 12.

Flexible ET efficiency evaluation method

The non-stationary request function $\eta_{H_i}(t)$ is characteristic for each H_i ($H_i \in \underline{H}$), i.e.

$$H_i \leftrightarrow \eta_{H_i}(t). \quad (6)$$

In any time t

$$\sum_{i=1}^{N_H} \eta_{H_i}(t) = 1. \quad (7)$$

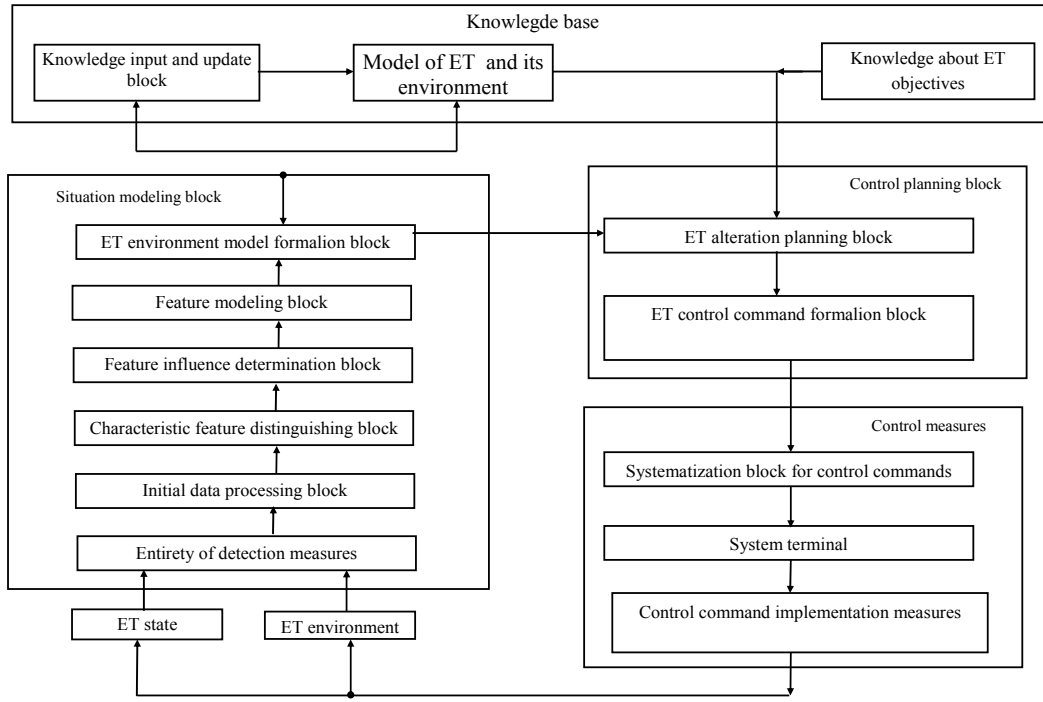

Fig. 12. Control scheme of ET component

Since the tasks $(\{H_i(t)\})$ are constantly improving, and everything that determines the technologies necessary in order to accomplish them also changes, which can be selected randomly from their set $\{T_{ij}(t)\}$, then

$$H_i(t) \longleftrightarrow p\{T_{ij}(t) = \langle \{S_{ij}(t)\}, \{K_{ij}(t)\}, \{S_{ij}(t)\}, \{D_{ij}(t)\}, \{A_{ij}(t)\}, \{V_{ij}(t)\} \rangle\}; \quad (8)$$

here $p\{\}$ – the probability of selecting $T_{ij}(t)$ for $H_i(t)$ task accomplishment.

Thus the request (demand) for the j -th technology when fulfilling the i -th task, will be $\eta_{T_{ij}}(t) \longleftrightarrow p\{\}$. It is clear that

$$\sum_{j=1}^{N_{T_i}} \eta_{T_{ij}}(t) = 1; \quad (9)$$

here N_{T_i} – overall number of alternative technologies used to accomplish the i -th task, and also at the same time the number of the initial frames.

The implementation graph of any j -th technology is presented in Fig. 13. In Fig. 13: PT_T – main terminal of the higher level; $T^{(s)}$ – the implementation block (terminal) of the s -th ET part; U_{ij} – the number of main parts (in the selected ET) of the j -th technology for the implementation of i -th task; PT_F – the main terminal of the lower level; F_{ij1} – the first frame of the lower level of i -th task in j -th technology; N_F – the number of secondary frames of the lower level; PF_{ijv} – the v -th sub-frame of the F_{ij1} frame. The states of all ET components shown in Fig. 13 are the functions of time. Therefore the efficiency of

their operation (task fulfillment probabilities) are constantly changing. Any component of ET (e.g. PF_{ijv}) will accomplish the task assigned to it, if it will operate properly and all the components below it in this graph will also operate properly. Si the efficiency of PF_{ijv}

$$E(PF_{ijv}, t) = P(PF_{ijv}, t) \cdot \prod_{s=1}^{\check{Z}_{ijv}} P_{ijv\check{Z}_s}(t); \quad (10)$$

here $P(\cdot)$ – PF_{ijv} component task fulfillment probability in time t ; $P_{ijv\check{Z}_s}$ – task fulfillment probability of the s -th component of the lowest level in time t ; \check{Z}_{ijv} – the number of the lowest level components, subordinate to PF_{ijv} sub-frames.

When s -th component is used for a relatively short time,

$$P_{ijv\check{Z}_s}(t) = \sum_{e=1}^{O_{ijv\check{Z}}} p\{\theta_{ijv\check{Z}_{se}}, t\} \cdot E_{ijv\check{Z}_{se}}(t); \quad (11)$$

here $\theta_{ijv\check{Z}_{se}}$ – e -th variant of s -th component performance (usage); $p\{\theta_{ijv\check{Z}_{se}}, t\}$ – the probability that this variant will be used in time t ; $O_{ijv\check{Z}}$ – the number of these variants; $E_{ijv\check{Z}_{se}}(t)$ – the usage efficiency of the mentioned variant in time t .

$$E_{ijv\check{Z}_{se}}(t) = f_{\check{Z}}(L_{1\check{Z}_{se}}^{(ijv)}, L_{2\check{Z}_{se}}^{(ijv)}, \{A_{ij}(t)\}, \{V_{ij}(t)\}, t); \quad (12)$$

here $L_{1\check{Z}_{se}}^{(ijv)}$ and $L_{2\check{Z}_{se}}^{(ijv)}$ – the sets of technical measures and processes taking place inside them when implementing the e -th component of this level.

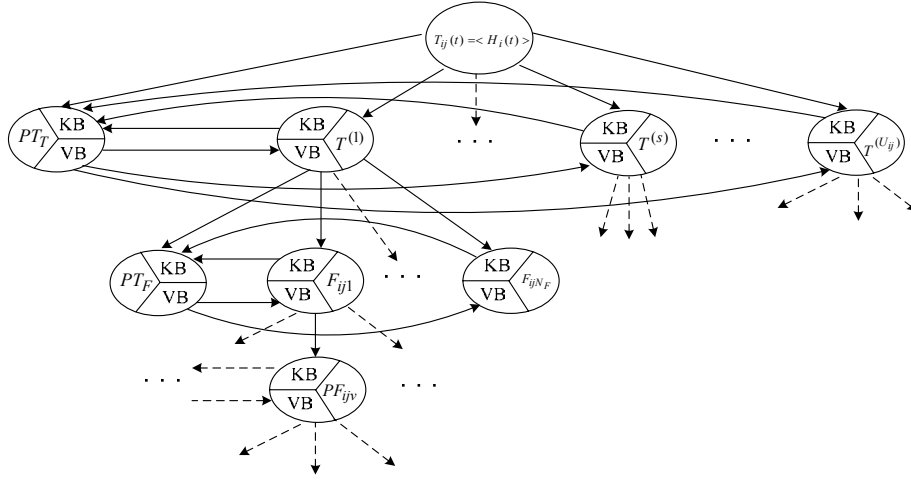

Fig. 13. The implementation graph of the flexible technology

Main expressions of $P(PF_{ijv}, t)$ can be written analogously:

$$P(PF_{ijv}, t) = \sum_{e=1}^{O_{ijvPF}} p\{\theta_{PFijve}, t\} \cdot E_{PFijve}(t); \quad (13)$$

$$E_{PFijve}(t) = f_{PF} \left(\underline{L}_{1PF_e}^{(ijv)}, \underline{L}_{2PF_e}^{(ijv)}, \{A_{ij}(t)\}, \{V_{ij}(t)\}, t \right); \quad (14)$$

denotations used here are analogous to indicated in (11) and (12) formulas; O_{ijvPF} – number of usage variants of the v -th sub-frame.

When the performance control of the frames of this level is applied using their main terminal over KB and VB, we have that

$$E(PF_{ijv}, t) = \left[\sum_{e=1}^{O_{ijvPF}} p\{\theta_{PFijve}, t\} \cdot [1 - (1 - E_{PFijve}(t)) \times (1 - E_{PFijve}^{(c)}(t))] \right] \cdot \prod_{s=1}^{\check{Z}_{ijv}} \left[\sum_{e=1}^{O_{ijv\check{Z}}} p\{\theta_{ijv\check{Z}se}, t\} \cdot [1 - (1 - E_{ijv\check{Z}se}(t)) \times (1 - E_{ijv\check{Z}se}^{(c)}(t))] \right]; \quad (15)$$

here $E_{PFijve}^{(c)}(t)$ and $E_{ijv\check{Z}se}^{(c)}(t)$ – the control efficiencies of the variants of e -th sub-frame and its lowest level component.

$$E_{PFijve}^{(c)}(t) = 1 - \frac{1 - E_{PFijve}^{(V)}(t)}{1 - E_{PFijve}(t)}; \quad (16)$$

$$E_{ijv\check{Z}se}^{(c)}(t) = 1 - \frac{1 - E_{ijv\check{Z}se}^{(V)}(t)}{1 - E_{ijv\check{Z}se}(t)}; \quad (17)$$

here $E_{PFijve}^{(V)}(t)$ and $E_{ijv\check{Z}se}^{(V)}(t)$ – the efficiencies of θ_{PFijve} and $\theta_{\check{Z}se}$ components, when they are controlled using the main terminal of this level.

General efficiency of the F_{ijl} frame

$$E(F_{ijl}, t) = \left[\sum_{e=1}^{O_{ijl}} p\{\theta_{Fijle}, t\} \cdot [1 - (1 - E_{Fijle}(t)) \times (1 - E_{Fijle}^{(c)}(t))] \right] \cdot \prod_{v=1}^{N_{PFijl}} \left[\sum_{e=1}^{O_{ijlv}} p\{\theta_{ijlve}, t\} \cdot [1 - (1 - E_{PFijve}(t)) \times (1 - E_{PFijve}^{(c)}(t))] \right]; \quad (18)$$

here O_{ijl} – number of usage variants of frame F_{ijl} ; $p\{\theta_{Fijle}, t\}$ – the probability of e -th usage variant of this frame (θ_{Fijle}) in time t ; $E_{Fijle}(t)$ – the efficiency of the e -th variant of component θ_{Fijl} in time t when the control is not implemented; $E_{Fijle}^{(c)}(t)$ – the control efficiency of this variant, when it is controlled from PT_F terminal; N_{PFijl} – the number of sub-frames, subordinate to the frame F_{ijl} ; O_{ijlv} – the number of usage variants of the v -th sub-frame, subordinate to F_{ijl} frame; θ_{ijlve} – e -th usage variant (component) of the v -th (from subordinate to the frame F_{ijl}) sub-frame; $p\{\theta_{ijlve}, t\}$ – the probability that this variant will be used.

The efficiency of the s -th terminal ($T^{(s)}$) – $E(T_{ijs}, t)$ – is expressed analogously.

$$E_{ET}(\underline{H}, t) = \sum_{i=1}^{N_H} \eta_{Hi}(t) \cdot E_i(t); \quad (19)$$

here $E_i(t)$ – i -th ET task accomplishment efficiency.

$$E_i(t) = \sum_{j=1}^{N_{Ti}} \eta_{Tij}(t) \cdot E_j(t); \quad (20)$$

here $E_j(t)$ – the efficiency of the j -th technology, when i -th task is performed.

$$E_{ij}(t) = E(T_{ij}, t) = E_{oij}(t) \cdot \prod_{s=1}^{U_{ij}} \left[\sum_{e=1}^{O_{ijs}} p\{T_{ijse}, t\} \right] \times$$

$$\times \left[1 - \left(1 - E_{ijse}(t) \right) \left(1 - E_{ijse}^{(c)}(t) \right) \right]; \quad (21)$$

here $E_{oij}(t)$ – the operation efficiency of the initial frame of the i -th task of j -th technology; O_{ijs} – number of variants of the s -th terminal of the i -th task of the j -th technology; $p\{T_{ijse}, t\}$ – usage probability of e -th variant of T_{ijse} terminal in time t . $E_{ijse}(t)$ – the efficiency of the e -th variant (without control) in time t ; $E_{ijse}^{(c)}(t)$ – the control efficiency of this variant.

$$E_{ijse}^{(c)}(t) = f_V \left(\underline{L}_{1PT_T}^{(ijs)}, \underline{L}_{2PT_T}^{(ijs)}, \{A_{ij}(t)\}, \{V_{ij}(t)\}, t \right); \quad (22)$$

here $\underline{L}_{1PT_T}^{(ijs)}$ and $\underline{L}_{2PT_T}^{(ijs)}$ – the sets of technical measures and processes taking place inside them of the main and other terminals when implementing the s -th variant of the j -th technology for the i -th task performance.

The advantages of the flexible ET efficiency evaluation method

When using ET efficiency evaluation method which is presented here, it is possible to calculate the task accomplishment probabilities of many different-purpose technologies.

This method provides the possibilities to evaluate permanent alterations of the separate ET components, at the same time ensuring its adaptivity and flexibility.

Method is adapted for the efficiency evaluation of ET with modular structure. The efficiency of the flexible ET significantly depends on its modularity. Therefore this ET creation technique is often used when creating flexible informational and manufacture technologies.

The other advantage of this method consist in the fact that when evaluating the efficiency of entire technology and separate components of it, the random usage character of each of them is considered.

It is possible to calculate generalized efficiency of entire ET or of the separate its variant (separate part) when applying this method. This method provides opportunities to investigate the efficiencies of the flexible ET of all four application areas (Fig. 1): used in devices, related to their application, device manufacture and their control.

References

1. **Словарь** иностранных слов. 10-е изд., стереотип. – Москва: Русский язык. 1993. – 608 с.
2. **Paulauskas K. V., Jasinevičius R.** Aiškinamasis kompiuterijos žodynas. – Kaunas: Technologija, 1995. – 370 p.
3. **Balaišis P., Eidukas D.** Radioelektroninių įtaisų kokybės dinamika. – Kaunas: KTU, 1991. – 182 p.
4. **Žickis A., Keras E.** Elektroninių gamybos valdymo priemonių tyrimas // Elektronika ir elektrotechnika. – Kaunas: Technologija, 2004. – Nr. 5(54). – P. 27-32.
5. **Balaišis P., Eidukas D., Valinevičius A., Žilys M.** Informacinių elektroninių sistemų efektyvumas. – Kaunas: Technologija, 2004. – 358 p.

Submitted for publication 2006 11 13

P. Balaišis, D. Eidukas, A. Žickis. Modeling of the Flexible Electronics Technologies // Electronics and Electrical Engineering. – Kaunas: Technologija, 2007. – No. 2(74). – P. 5–12.

The structural scheme of flexible electronic technologies (ET) was formed. Main directions for investigations of these technologies were pointed out. Main ET development peculiarities, the dependence of the flexibility degree on the intensity of application and the dynamics principles of these technologies were analyzed. When synthesizing flexible ET the method of hierarchy formation of controlled frames is used. ET task accomplishment probability was selected as the index of the flexible ET technical efficiency. Flexible ET efficiency evaluation method was created using the frame hierarchy and its control schemes. The offered method provides the possibilities to calculate generalized efficiency of all ET of the selected area and (or) branch. Ill. 13, bibl. 5 (in English; summaries in English, Russian and Lithuanian).

П. Балайшис, Д. Эйдукас, А. Жицкис. Моделирование гибких технологий электроники // Электроника и электротехника. – Каунас: Технология, 2007. – № 2(74). – С. 5–12.

Составлена структурная схема гибких технологий электроники. Приведены основные направления исследований этих технологий. Исследованы основные особенности развития указанных технологий. Показана зависимость степени гибкости указанных технологий от интенсивности их применения. Выделены два направления развития гибких технологий электроники (энтодинамика и экзодинамика). При синтезе гибких технологий электроники применяется способ составления иерархии управляемых фреймов. В качестве показателя технической эффективности гибких технологий электроники выбрана вероятность выполнения ими задания. Используя схемы иерархии фреймов и управления ими разработан метод оценки эффективности гибких технологий электроники. Предложенный метод позволяет рассчитать обобщенную эффективность всех технологий выбранной области или выбранного направления. Ил. 13, библи. 5 (на английском языке; рефераты на английском, русском и литовском яз.).

P. Balaišis, D. Eidukas, A. Žickis. Lanksčiųjų elektronikos technologijų modeliavimas // Elektronika ir elektrotechnika. – Kaunas: Technologija, 2007. – Nr. 2(74). – P. 5–12.

Sudaryta lanksčiųjų elektronikos technologijų (ET) struktūrinė schema. Nurodytos pagrindinės šių technologijų tyrimų kryptys. Išanalizuoti pagrindiniai ET plėtros ypatumai, lankstumo laipsnio priklausomybė nuo panaudojimo intensyvumo bei šių technologijų dinamikos principai. Sintezuojant lanksčiąsias ET naudojamas valdomų freimų hierarchijos sudarymo būdas. Lanksčiųjų ET techninio efektyvumo rodikliu pasirinkta jų užduočių įvykdymo tikimybė. Naudojant freimų hierarchijos ir jų valdymo schemas sudarytas lanksčiųjų ET efektyvumo vertinimo metodas. Pasiūlytas metodas įgalina apskaičiuoti apibendrintą visų pasirinktos srities ar (ir) krypties ET efektyvumą. Il. 13, bibl. 5 (anglų kalba; santraukos anglų, rusų ir lietuvių k.).

DOI: 10.5755/j02.eie.10348